

# SOMMERKAMP

CITIZENS BAND  
FM TRANSCEIVER  
0.5 WATTS  
P.L.L SYNTHESIZED

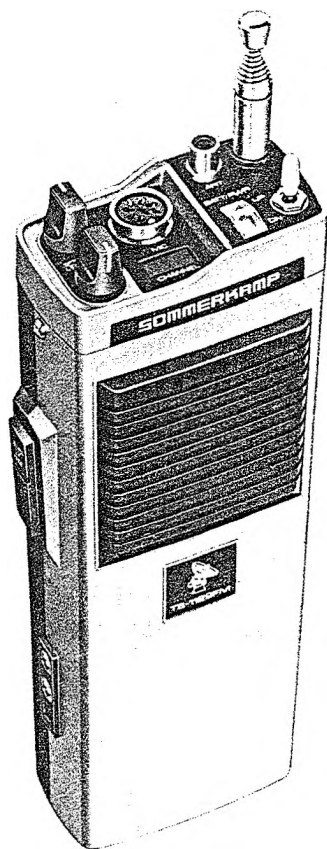

MODEL

TS-1122FM

INSTRUCTION MANNUAL

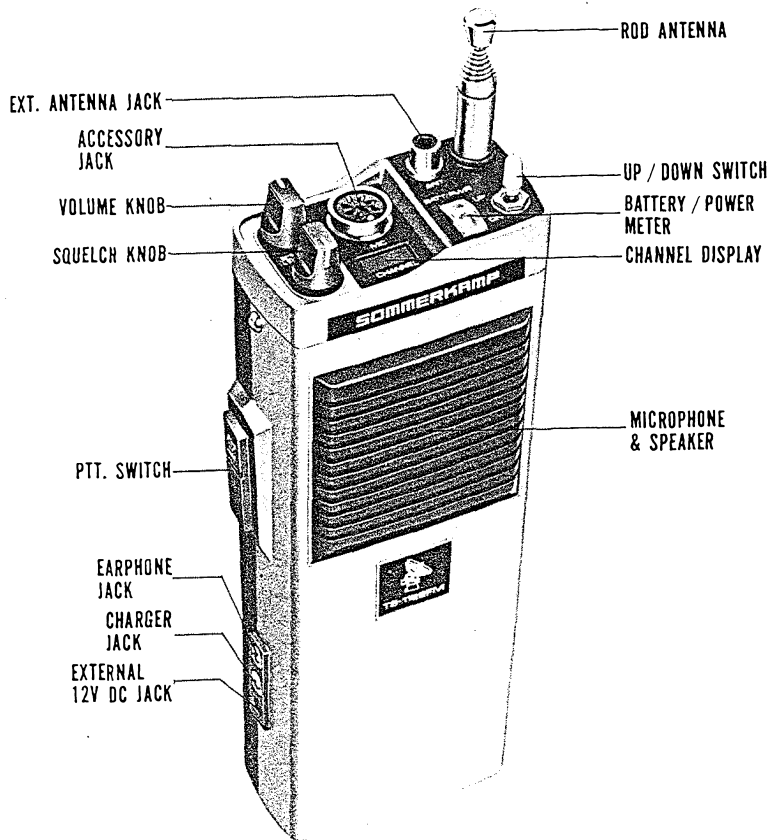

#### PACKING LIST:

Beside this manual, the carton contains the following items:

1. Transceiver
2. Carrying case with shoulder strap
3. Earphone case with earphone
4. 2 pcs. dummy batteries inside the battery case

## GENERAL DESCRIPTION

The SOMMERKAMP TS-1122FM transceiver is designed for continuous heavy duty portable use. It can be operated with an external antenna, a short rubber type antenna, an external power supply, a headset, a telephone set incorporating automatic voice operated transmit/receive switching and an external selective tone call system PARROT 76 with automatic answer back and many more.

The transceiver is a 500mW output, frequency synthesized solid state radio set, designed for FM transmission and reception in the 27MHz range.

Frequency control employs state of the art digital circuitry combined with a precision phase locked VCO to provide 22 transmit and receive channels in 25KHz increments. The operational channel number is displayed by large attractive LED numerics.

## FEATURES AND CONTROLS

### VOLUME/ON-OFF

The transceiver is switched on as a click is heard rotating this knob clockwise. The receiver volume is increased as it is turned further clockwise.

### SQUELCH/LED-ON

The squelch control is used to eliminate background noise when there is no signal present. To adjust the squelch, select a channel where there is no signal. Turn the volume control knob to a normal listening level. Then rotate the squelch control knob clockwise slowly until the background noise just disappears. Rotating the knob marked LED/SQU to the right beyond an audible click will switch off the LED channel display which would stay illuminated in a fully counter-clockwise position.

### CHANNEL UP/DOWN SWITCH

This toggle switch will change the channels electronically. By pushing it forward, the channel number will increase. Conversely, by pulling it, the channel number decreases. Upon pushing or pulling this switch, the LED channel display will light up but extinguishes automatically to save battery consumption if the squelch control knob is turned to the right beyond the click.

### AUTOMATIC UP/DOWN SCANNING

One of the unique features of this transceiver is the automatic up/down scanning. Upward or downward automatic scanning is possible by pushing or pulling the UP/DOWN toggle switch for a continuous few seconds.

On the other hand, the automatic scanning is also possible if the special SOMMERKAMP remote control microphone be connected to the 8-pin accessory jack and the UP or DOWN button on the microphone be kept pushed for a few seconds.

## UNPACKING AND CHECKOUT

Unpack this carton carefully and check for exterior damage. Verify if the volume control is in the OFF position. The squelch control should be in its fully counter-clockwise position. Press the dent of the battery compartment lid and pull it out toward the bottom of the set. Lift out the battery holder and insert 8 dry cells into the holder as indicated by the drawing.

+ plus to +, - minus to - pole. Leave the two dummy batteries in the holder. Should you use rechargeable batteries, insert 10 pieces of them in the same manner as above but remove the two dummy batteries. Snap the battery holder into the snap connector provided and reinsert the holder into the compartment. Replace the compartment lid by inserting it straight from the bottom up until it snaps into position rightly.

Extend the rod antenna to the full length. Now switch the transceiver ON by rotating the volume control knob clockwise and check that the meter needle moves into the green field. If the meter needle does not move at all, open the

battery compartment to remove the battery holder and verify that all batteries are inserted correctly.

Next turn the volume control clockwise until some noise is being heard from the loudspeaker. Operate the channel up/down switch to ensure that some noise and/or signal is received.

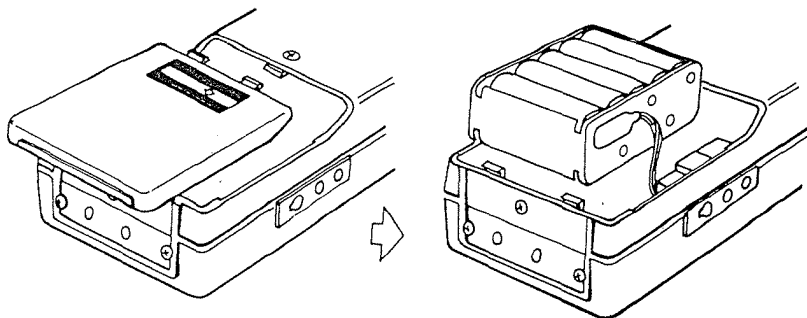

## OPERATION

Switch the transceiver on by rotating the volume control knob clockwise. The set is immediately ready for transmit/receive on the CH-9. Select the desired channel by operating the channel up/down switch. Adjust the volume control to a comfortable level.

Press the PTT switch and talk from a distance of 5-10cm with a normal voice into the microphone located behind the front grill. After completing your transmission, release the PTT switch. The transceiver will then be ready for reception. Always remember that your opposite party cannot hear you while he is transmitting himself. Adjust the squelch control so that any background noise just disappears. Perform squelch adjustment only during non-transmitting periods of your opposite party.

To answer a received call, push the PTT switch and talk into the microphone. To receive weak signals, turn the squelch control fully counter clockwise. To switch the transceiver off, turn the volume control fully counter clockwise until a click is heard and the meter needle moves back into the red field.

### Important Hint:

If the transceiver is not operated for a long time, remove the batteries from the holder. This way, a decayed battery will not damage the transceiver.

The same applies, should the transceiver be used continuously with an external power supply.

## POWER SOURCES

This transceiver is designed to operate on a power supply of normal 12V DC such as from internal dry cells or nickel-cadmium rechargeable batteries or from an external power supply delivering at least 1 ampere. The set will, however, operate from 10-16V DC without any damage. To use the set with an external power supply, insert a plug of the power supply into the external power jack provided.

## BATTERY CHARGER STAND

On the bottom of the cabinet, there are battery charger contacts provided. Consult a SOMMERKAMP dealer for the proper charger stand.

When you use rechargeable batteries, charge them either by plugging an appropriate battery charger into the charger jack located on the left hand side of the set or by inserting the transceiver into a battery charger stand.

Charge the batteries for about 14 hours. It is not possible to operate the set during battery charging.

To connect the set to a 12V automobile battery, use a 1A fuse in series with the positive wire. Solder the positive wire to the center of the external power plug and the negative wire to its fin.

For private listening, plug an earphone piece into the earphone jack provided. The internal speaker will then disconnect automatically.

To operate the transceiver on a 50 ohm external antenna, connect it to EXT. ANT jack provided on the top.

## CHANNEL 9

It is so designed that the transceiver is switched on always with the channel 9 which is the Emergency Channel.

## LIST OF CHANNEL FREQUENCY

CH.	FREQ.	CH.	FREQ.	CH.	FREQ.	CH.	FREQ.
1	26,965	7	27,035	13	27,115	19	27,185
2	26,975	8	27,055	14	27,125	20	27,205
3	26,985	9	27,065	15	27,135	21	27,215
4	27,005	10	27,075	16	27,155	22	27,225
5	27,015	11	27,085	17	27,165		
6	27,025	12	27,105	18	27,175		

# MIC JACK

The 8-pin DIN standard Mic jack has the following internal connections:

- |                                    |                               |
|------------------------------------|-------------------------------|
| 1. Microphone input (Z600-10K ohm) | 6. +12V for VOX unit etc.     |
| 2. Transmit/Receive switching      | 7. AF out for selective call. |
| 3. Ground (SP)                     | 8. SQUELCH                    |
| 4. Audio output. (Z8-10K ohm)      | Case = ground                 |
| 5. Internal speaker.               |                               |

Always operate the transceiver with the microphone plug inserted in the microphone jack, or with the following external connections:

1. Microphone with VOX.

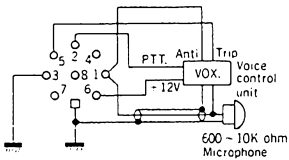

2. Headset or Telephoneset with PTT.

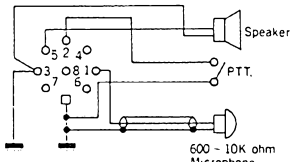

3. External microphone

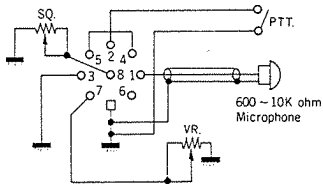

4. Headset or Telephoneset with VOX.

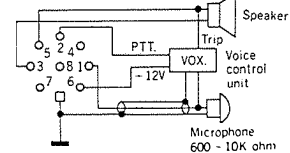

5. External microphone/Speaker with PTT.

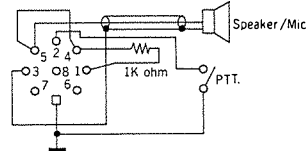

6. Internal connection

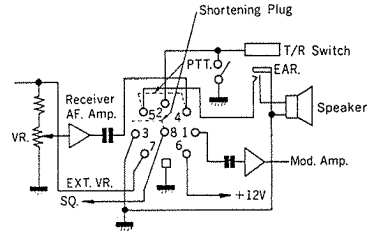

7. Internal connection with SP. selection switch

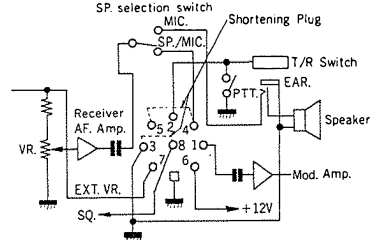

8. Parrot 76

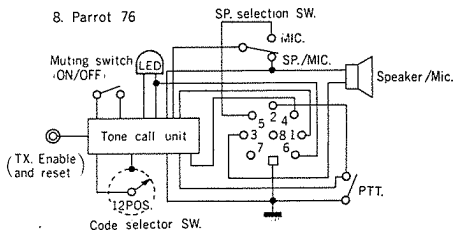

BLOCK DIAGRAM

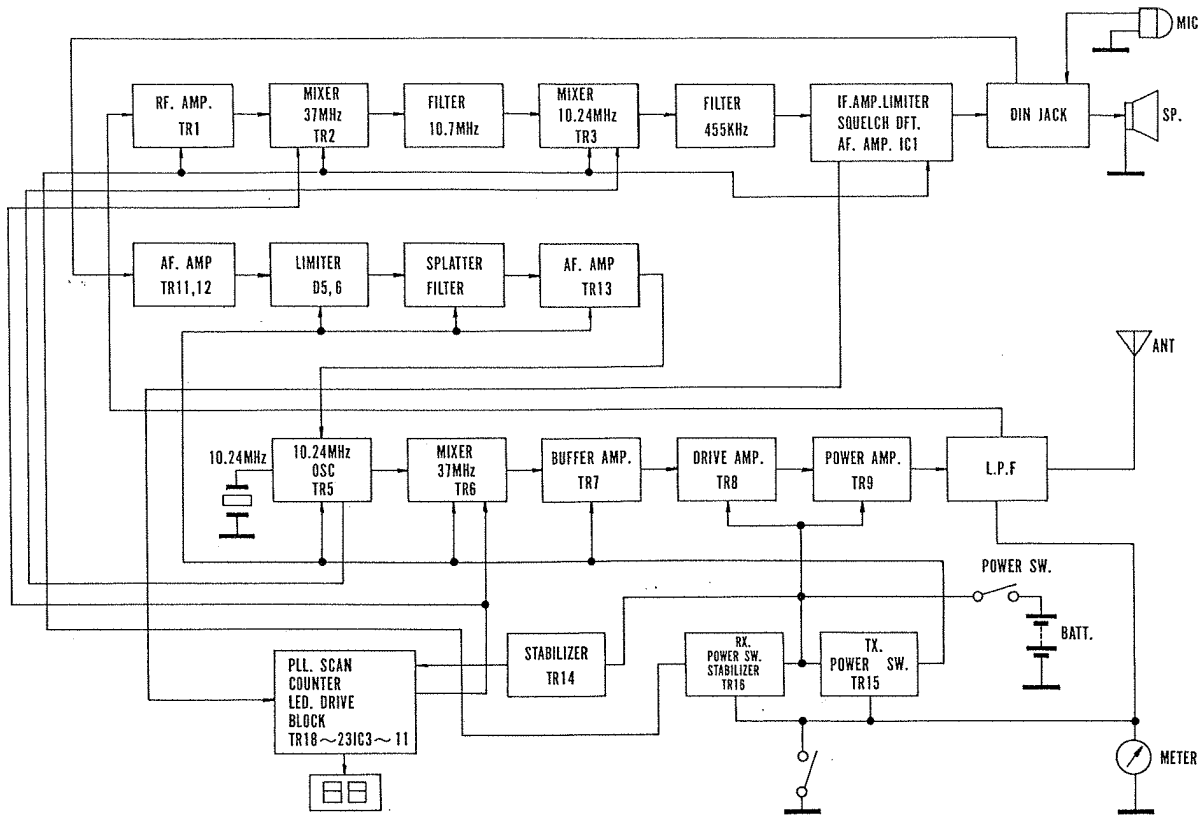

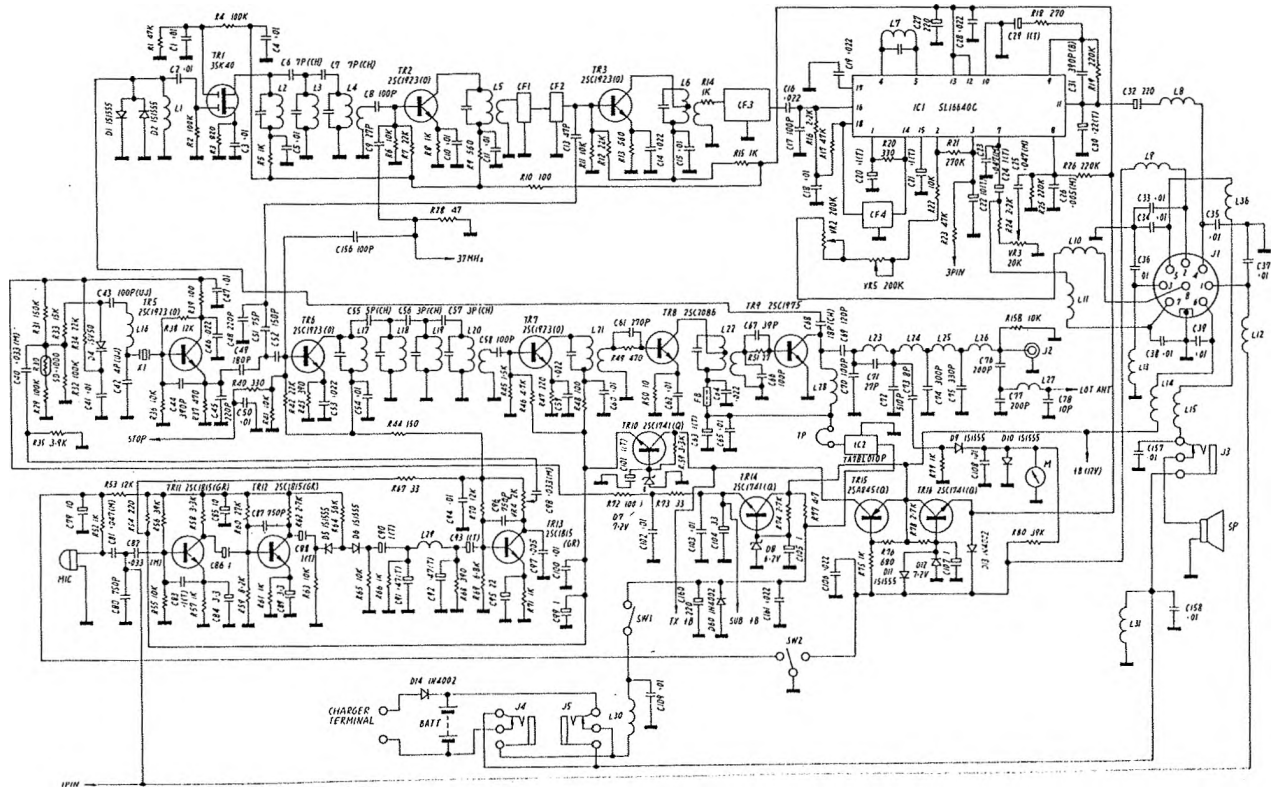







# WIRING LAYOUT

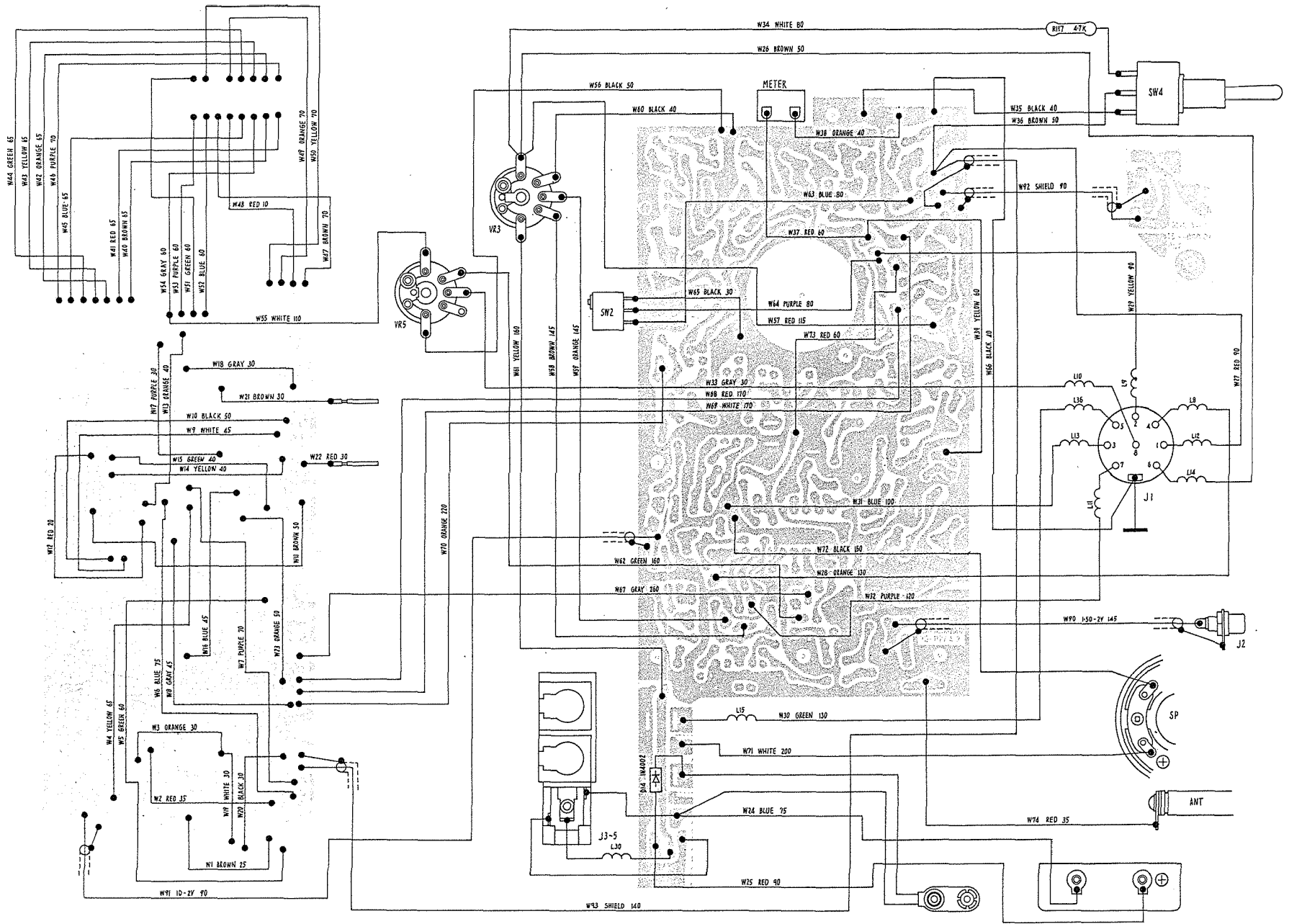

# PARTS LAYOUT (MAIN)

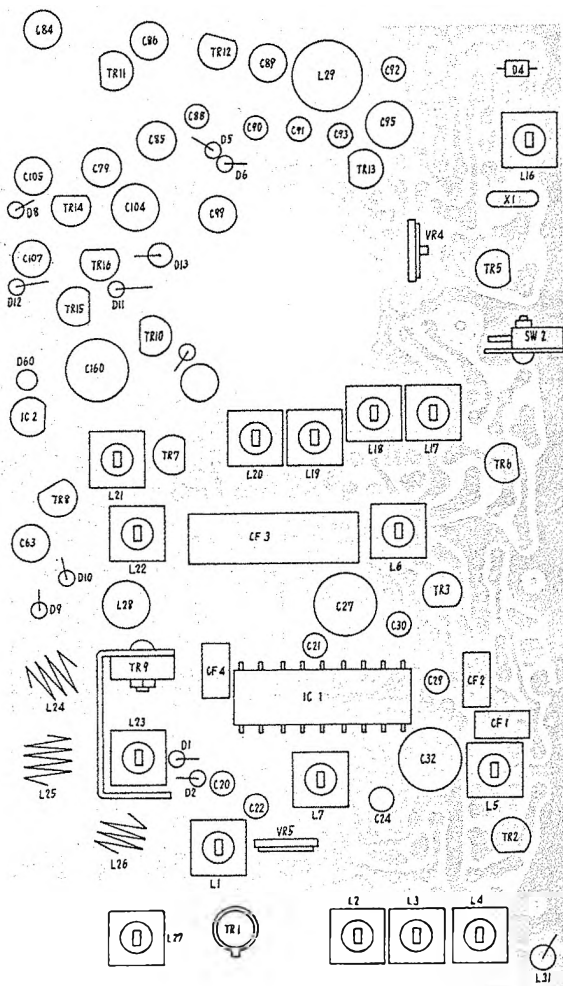

PARTS LAYOUT (SUB)

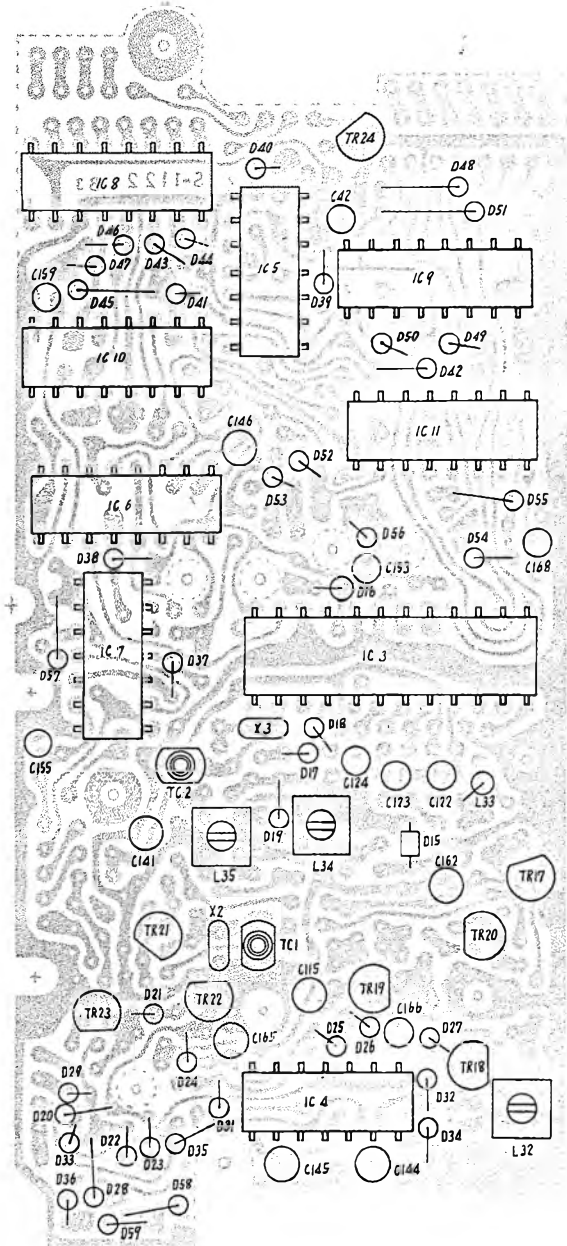

## PARTS LIST (TS-1122FM)

DESIGNATION	PARTS NAME	PARTS NO.
MP-5601	Cabinet Front	553101
MP-5602	Cabinet Top	553102
MP-5603	Cabinet Back	492021
MP-5604	Cabinet Cover for Battery	493039
MP-5605	Speaker Grill	553103
MP-5609	Cabinet Bottom Plate	544612
MP-5608	P. T. T. Button Assembly	494200
MP-5607	Knob for VOL. SQU. Control	494199
MP-610	P. C. B Frame (A)	554713
MP-611	P. C. B Frame (B)	554723
MP-612	DIN JACK Spacer	534556
MP-209	Mounting Bracket for Speaker	474009
MP-613	Button Spring	494206
MP-576	Charger Terminal	544613
MP-577	Micro SW. Fixing Metal	544618
MP-559	Battery Case Holder	494194
MP-614	Speaker Cover	484050
MP-5615	Brand Plate	494223
MP-5616	Push Plate	494222
MP-578	VOL. SQU. Plate	494208
MP-579	DIN JACK Plate	554708
MP-580	Back Plate	544655
MP-581	SOMMERKAMP Mark Plate	544652
MP-5624	Speaker Net	494229
MP-615	Channel Plate	554734
MP-583	LED Spacer	534592
MP-616	Shield Plate	554741
MP-585	Push Button Spacer	544649
MP-617	P. C. Board Supporter (A)	554742
MP-618	P. C. Board Supporter (B)	554743
MP-619	P. C. Board Supporter (C)	554744
MP-5624	Rod Antenna Cover	494219
MP-5606	Bushing for Rod Antenna	494205
MP-5611	Cap for EXT. ANT. Jack	494204
MP-5610	Mounting Bracket for Rod Antenna	494202
MP-620	Shield Plate Spacer	554740
MP-621	LED Filter	554736
MP-622	Shield Plate	554706
MP-623	SP Cover	544670

## PARTS LIST (TS-1122FM)

DESIGNATION	PARTS NAME	PARTS NO.
TR1	FET	3SK40 (L)
TR2,3,5,6,7,17,18,19,21	Transistor	2SC1923 (O)
TR8	Transistor	2SC2086
TR9	Transistor	2SC1957
TR10, 14, 16	Transistor	2SC1741 (Q)
TR11, 12, 13, 22	Transistor	2SC1815 (GR)
TR15	Transistor	2SA854 (Q)
TR20	FET	2SK19 (GR)
TR23	Transistor	2SA1015 (Y)
TR24	Transistor	2SC1646 (B)
IC1	IC	SL16640C
IC2	IC	TA78L010P
IC3	IC	$\mu$ PD2810C
IC4, 7	IC	TC4011BP
IC5	IC	TC4081BP
IC6	IC	MC14572UB
IC8, 9	IC	TC5022BP
IC10, 11	IC	TC4510BP
D1, 2, 5, 6, 9, 10, 11, 19, 20, 22~57, 58, 59	Silicon Diode	IS1555
D13, 14, 60	Silicon Diode	IN4002
D16	Germanium Diode	IN60
D4, 15	Variable Capacitance Diode	ISV50
D7, 12, 21	Zener Diode	WZ072
D8	Zener Diode	WZ062
D17, 18	RF Diode	M1301
LED1, 2	LED	
CF1, 2	Ceramic Filter	SFE10.7
CF3	Ceramic Filter	CFR455H
CF4	Ceramic Filter	SFU455B
X1	X'tal 10.24 MHz	
X2	X'tal 36.29 MHz	30/U
X3	X'tal 10.24 MHz	30/U
TC1	Trimmer Condenser	CV05A060
TC2	Trimmer Condenser	CV05E3001
M	Meter	500 $\mu$ A
MIC	Condenser Mic	WMO65W
FB	Ferrite Beads	T314 OP3.5-3H
J1	Mic Jack	DIN Type
J2	EXT. ANT. Jack	RCA Type

# PARTS LIST (TS-1122FM)

DESIGNATION	PARTS NAME	PARTS NO.
J3, 4, 5	Tri Jack	C-G0112-01
SP	Speaker	77-08
SW2	Micro SW	D2MQ1
VR2	Semi Variable Resister 200K	SVR200KS2
VR4	Semi Variable Resister 2K	SVR002KS3
VR3	Variable Resister 20K	20FHA-V-12M4-IS (SJ)
VR5	Variable Resister 200K	20FHA-V-12M4-IS (SJ)
SW4	Toggle SW.	MS-500E
ANT	Rod Antenna	A-32
L1	RX. RF. Coil	361-060
L2,3,4,17,18,19,20,21	RX. RF. Coil/TX. 27 MHz Coil	361-058
L5	RX. IF. Coil	011-904
L6, 7	RX. IF. Coil	269-102
L16	10.24 MHz OSC Coil	361-057
L22	TX. 27 MHz Coil	361-059
L28	TX. Choke Coil	269-602
L23	TX. Final Tune Coil	361-852
L24, 25, 26	L. P. F Coil	011-917
L27	ANT. Tune Coil	361-851
L8, 9, 10, 11, 12, 13, 14, 15, 30, 31, 36	R. F. C	005-903
L32	RX. RF. Coil	361-063
L33	L. P. F	313-602
L34	P. L. L L. P. F	361-061
L35	Local Tune Coil	361-062
L29	R. F. C	FL9H333J

## SPECIFICATIONS

### GENERAL

Frequency Range:	26.965 MHz~27.225 MHz (1~22 ch)
Frequency Control:	Digitally synthesized PLL system
Frequency Stability:	$3 \times 10^{-6}$ at 25°C $8 \times 10^{-6}$ at -10°C to +50°C
Semiconductor Compliments:	21 Transistors, 2 FETs, 11 ICs, 58 Diodes
Modulation Type:	Frequency Modulation
Supply Voltage:	12 Volt DC
Current Drain:	Transmit: 0.155A (off LED) Receive: 0.025A
Antenna Impedance:	50 Ohms unbalanced
Size:	230 mm X 78 mm X 43.5 mm

### TRANSMITTER

Frequency Control:	Phase Locked Loop Synthesizer
Modulation:	FM
Power Output:	0.5W
Deviation:	$\pm 1.5$ KHz
Microphone:	Condenser microphone

### RECEIVER

Frequency Scheme:	Double Superheteodyne
Sensitivity:	$1 \mu$ V for 20 db sinad $1 \mu$ V squelch threshold
Selectivity:	$\pm 3$ KHz (-6 db) $\pm 7.5$ KHz (-70 db)
Audio Output Power:	250 mW at 8 ohm 10% THD

**SOMMERKAMP ELECTRONIC SAS**

CH-6903 LUGANO, P. O. BOX 176

SWITZERLAND

TEL.(91)688543 TELEX 79314