

Albrecht AE 4200 Platinenplan/PCB Layout

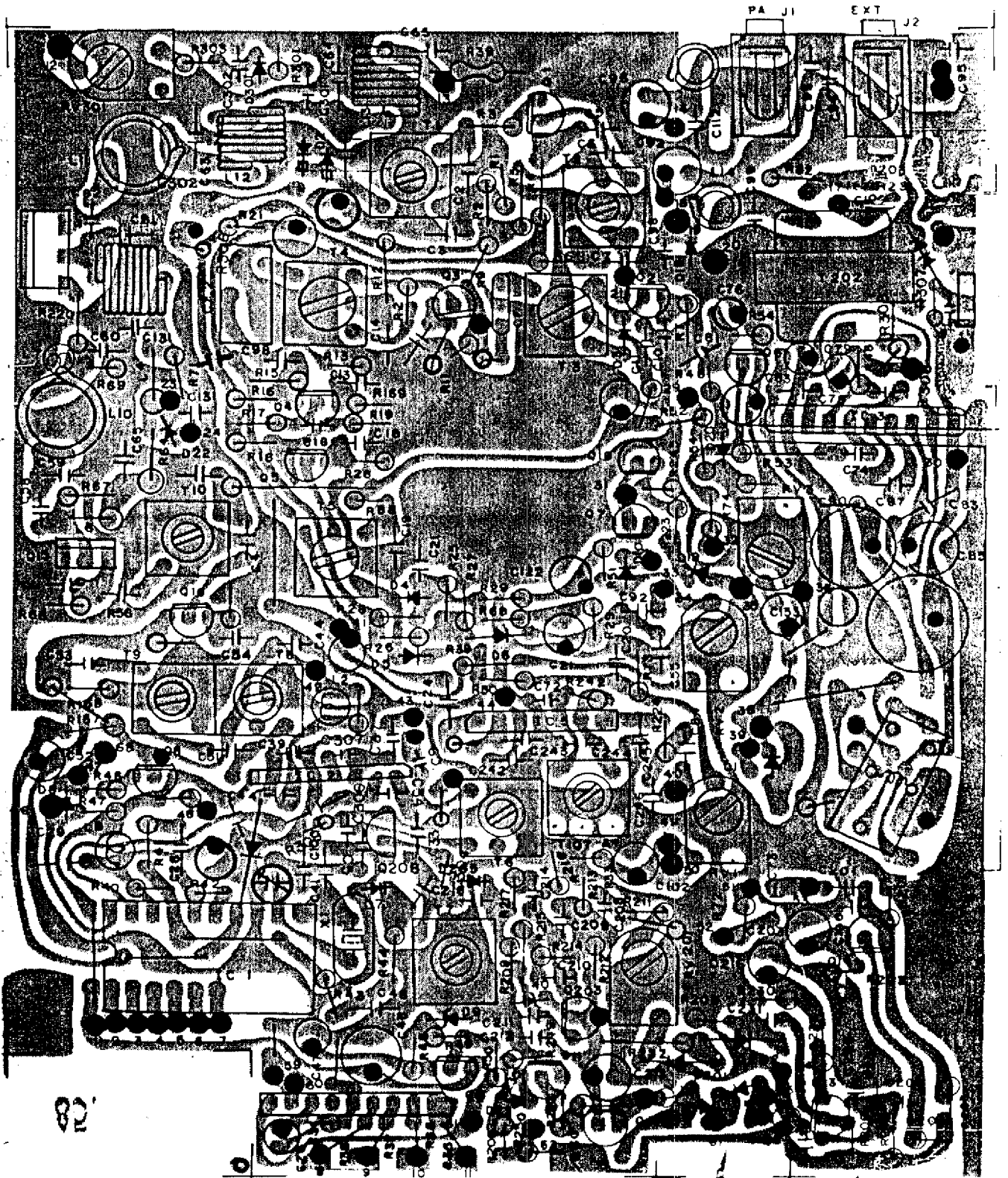

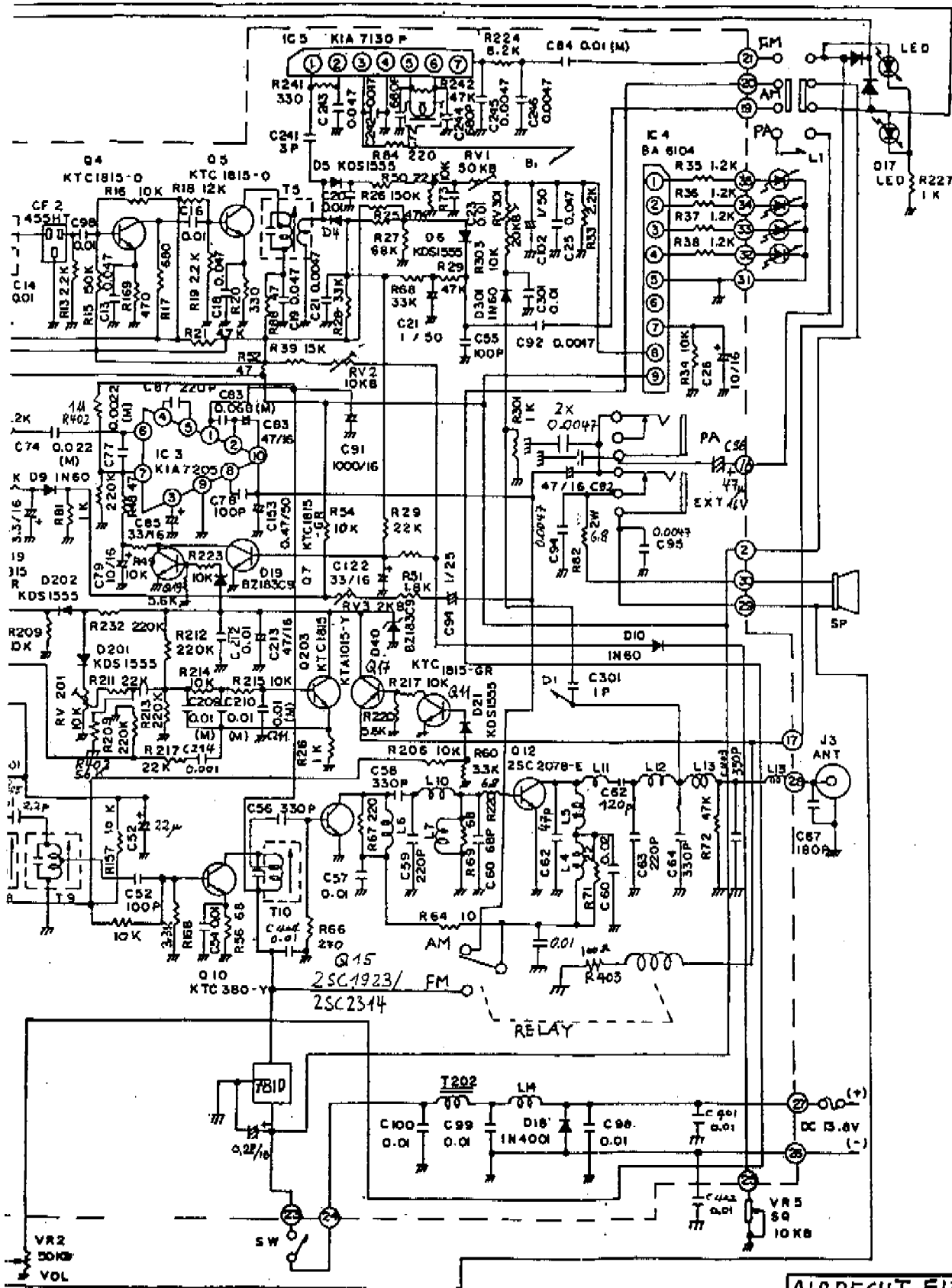

ALBRECHT-ELECTRONIC
 AE 4200
 DBP KAM-8186
 Z 220016 98a

T5

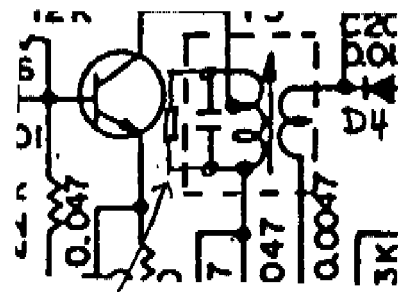

Zur Vermeidung von Schwingneigung
 in der ZF Widerstand 47k-56 k einlöten

Albrecht AE 4200 Kanalbegrenzung 12 K / AM

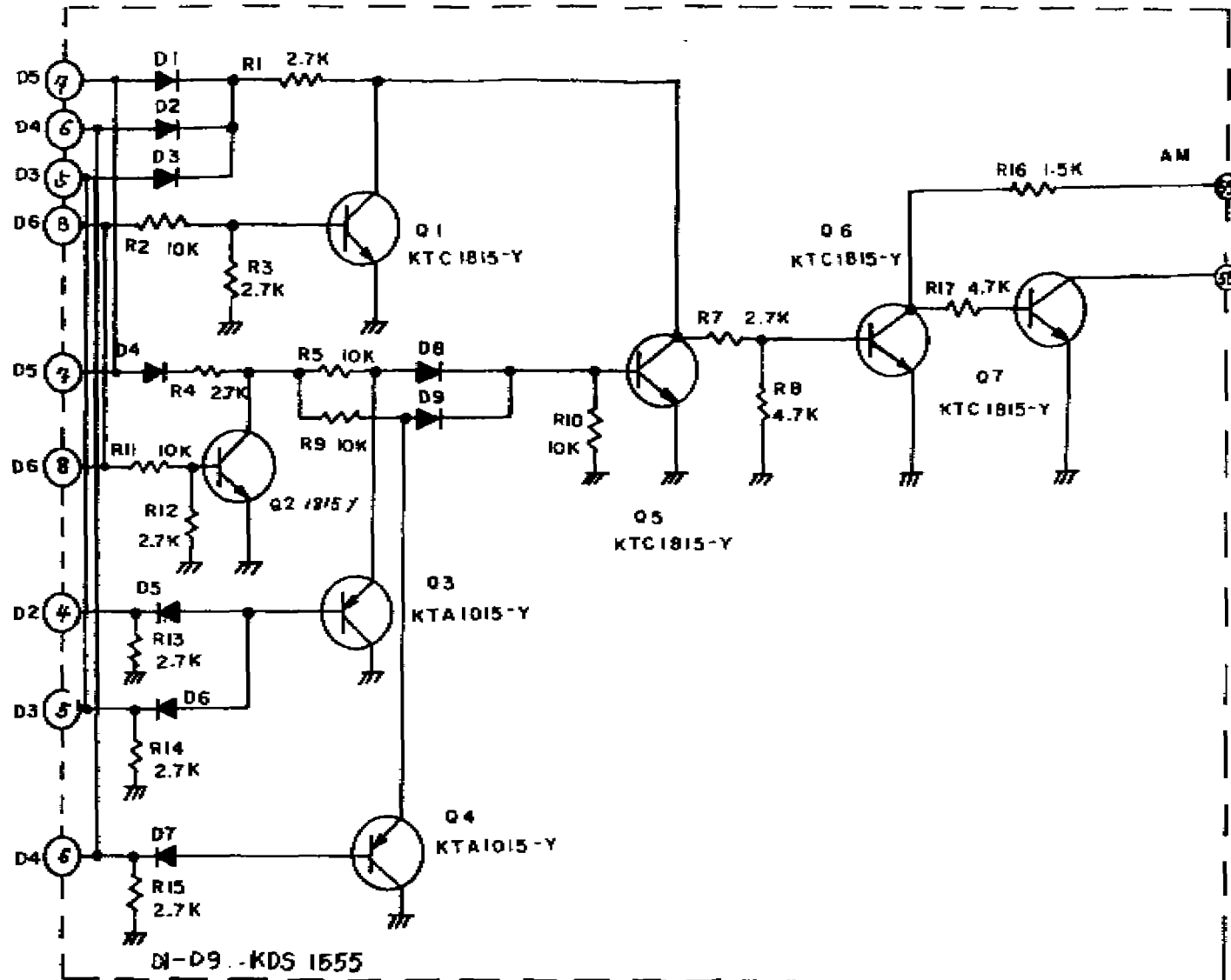

ALBRECHT AE 4200
Kanalbegrenzung 12 CH - AM
Z 120046

ALBRECHT AE 4200 TEIL 1

