

# UTC 79LXX LINEAR INTEGRATED CIRCUIT

## 3-TERMINAL 0.1A NEGATIVE VOLTAGE REGULATOR

### DESCRIPTION

The UTC 79LXX family is monolithic fixed voltage regulator integrated circuit. They are suitable for applications that required supply current up to 100mA.

### FEATURES

- \*Output current up to 100mA
- \*Fixed output voltage of -5V, -6V, -8V, -9V, -12V, -15V, -18V and -24V available
- \*Thermal overload shutdown protection
- \*Short circuit current limiting

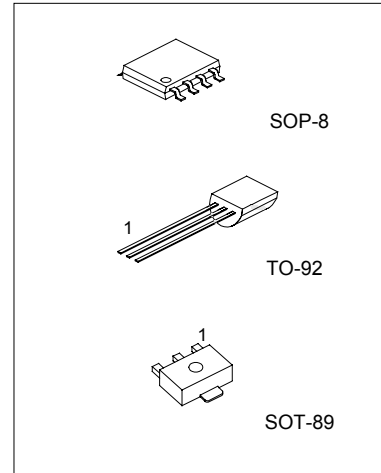

SOP-8 : 1. Vout ; 2,3,6,7 Vin ; 5. GND; 4,8 NC

TO-92 : 1: GND 2: Input 3: Output

SOT-89: 1: GND 2: Input 3: Output

### TEST CIRCUIT

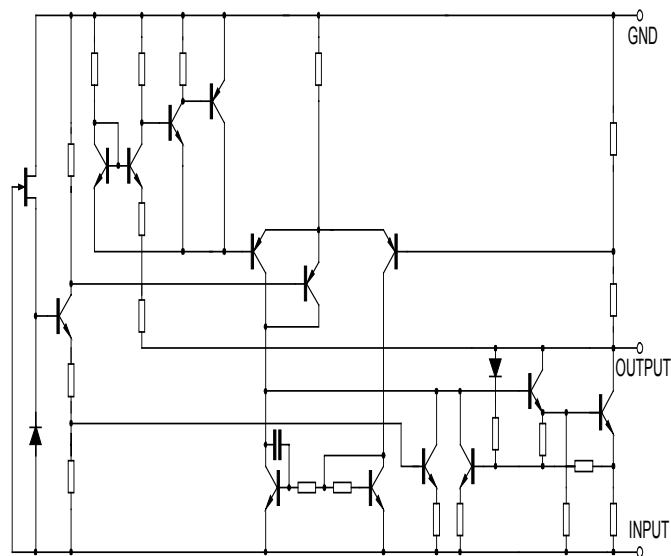

# UTC79LXX LINEAR INTEGRATED CIRCUIT

## ABSOLUTE MAXIMUM RATINGS ( Operating temperature range applies unless otherwise specified )

PARAMETER	SYMBOL	VALUE	UNIT
Input voltage(for Vo=-5~-9V) (for Vo=-12~-15V) (for Vo=-18~-24V)	V <sub>I</sub>	-30	V
	V <sub>I</sub>	-35	V
	V <sub>I</sub>		
Power Dissipation	P <sub>D</sub>	350 (SOT-89) 300 (SOP-8) 500 (TO-92)	mW
Operating Junction Temperature Range	T <sub>OPR</sub>	-30 ~ +125	°C
Storage Temperature Range	T <sub>STG</sub>	-40 ~ +125	°C

## UTC79L05 ELECTRICAL CHARACTERISTICS

(T<sub>J</sub>=25°C, C<sub>1</sub>=0.33μF, C<sub>o</sub>=0.1μF, unless otherwise specified)

PARAMETER	SYMBOL	TEST CONDITIONS	MIN	TYP	MAX	UNIT
Output Voltage	V <sub>o</sub>	V <sub>IN</sub> =-10V, I <sub>o</sub> =40mA	-4.8	-5.0	-5.2	V
Line Regulation	V <sub>o</sub> -V <sub>IN</sub>	V <sub>IN</sub> =-7~-20V, I <sub>o</sub> =40mA		15	150	mV
Load Regulation	V <sub>o</sub> -I <sub>o</sub>	V <sub>IN</sub> =-10V, I <sub>o</sub> =1~100mA		7	60	mV
Quiescent current	I <sub>Q</sub>	V <sub>IN</sub> =-10V, I <sub>o</sub> =40mA		3.5	6.0	mA
Ripple Rejection	RR	V <sub>IN</sub> =-8~-18V, I <sub>o</sub> =40mA, E <sub>in</sub> =1Vp-p, f=120Hz	41	71		dB
Output Noise Voltage	V <sub>NO</sub>	V <sub>IN</sub> =-10V, BW=10Hz~100kHz, I <sub>o</sub> =40mA		120		μV

## UTC79L06 ELECTRICAL CHARACTERISTICS

(T<sub>J</sub>=25°C, C<sub>1</sub>=0.33μF, C<sub>o</sub>=0.1μF, unless otherwise specified)

PARAMETER	SYMBOL	TEST CONDITIONS	MIN	TYP	MAX	UNIT
Output Voltage	V <sub>o</sub>	V <sub>IN</sub> =-12V, I <sub>o</sub> =40mA	-5.76	-6.0	-6.24	V
Line Regulation	V <sub>o</sub> -V <sub>IN</sub>	V <sub>IN</sub> =-8.5~-20V, I <sub>o</sub> =40mA		15	150	mV
Load Regulation	V <sub>o</sub> -I <sub>o</sub>	V <sub>IN</sub> =-12V, I <sub>o</sub> =1~100mA		7	60	mV
Quiescent current	I <sub>Q</sub>	V <sub>IN</sub> =-12V, I <sub>o</sub> =40mA		3.5	6.0	mA
Ripple Rejection	RR	V <sub>IN</sub> =-9~-19V, I <sub>o</sub> =40mA, E <sub>in</sub> =1Vp-p, f=120Hz	41	71		dB
Output Noise Voltage	V <sub>NO</sub>	V <sub>IN</sub> =-12V, BW=10Hz~100kHz, I <sub>o</sub> =40mA		120		μV

## UTC79L08 ELECTRICAL CHARACTERISTICS

(T<sub>J</sub>=25°C, C<sub>1</sub>=0.33μF, C<sub>o</sub>=0.1μF, unless otherwise specified)

PARAMETER	SYMBOL	Test conditions	MIN	TYP	MAX	UNIT
Output Voltage	V <sub>o</sub>	V <sub>IN</sub> =-14V, I <sub>o</sub> =40mA	-7.68	-8.0	-8.32	V
Line Regulation	V <sub>o</sub> -V <sub>IN</sub>	V <sub>IN</sub> =-10.5~-23V, I <sub>o</sub> =40mA		24	175	mV
Load Regulation	V <sub>o</sub> -I <sub>o</sub>	V <sub>IN</sub> =-14V, I <sub>o</sub> =1~100mA		10	80	mV
Quiescent current	I <sub>Q</sub>	V <sub>IN</sub> =-14V, I <sub>o</sub> =40mA		3.5	6.0	mA
Ripple Rejection	RR	V <sub>IN</sub> =-11~-21V, I <sub>o</sub> =40mA, E <sub>in</sub> =1Vp-p, f=140Hz	39	68		dB
Output Noise Voltage	V <sub>NO</sub>	V <sub>IN</sub> =-14V, BW=10Hz~100kHz, I <sub>o</sub> =40mA		190		μV

# UTC79LXX LINEAR INTEGRATED CIRCUIT

## UTC79L09 ELECTRICAL CHARACTERISTICS

(Tj=25°C, C1=0.33μF, Co=0.1μF, unless otherwise specified)

PARAMETER	SYMBOL	TEST CONDITIONS	MIN	TYP	MAX	UNIT
Output Voltage	Vo	VIN=-15V, Io=40mA	-8.64	-9.0	-9.36	V
Line Regulation	Vo-VIN	VIN=-12.5~-24V, Io=40mA		27	200	mV
Load Regulation	Vo-Io	VIN=-15V, Io=1~100mA		12	90	mV
Quiescent current	Iq	VIN=-15V, Io=40mA		3.5	6.0	mA
Ripple Rejection	RR	VIN=-12~-22V, Io=40mA, Ein=1Vp-p, f=150Hz	37	64		dB
Output Noise Voltage	VNO	VIN=-15V, BW=10Hz~100kHz, Io=40mA		210		μV

## UTC79L12 ELECTRICAL CHARACTERISTICS

(Tj=25°C, C1=0.33μF, Co=0.1μF, unless otherwise specified)

PARAMETER	SYMBOL	TEST CONDITIONS	MIN	TYP	MAX	UNIT
Output Voltage	Vo	VIN=-19V, Io=40mA	-11.52	-12.0	-12.48	V
Line Regulation	Vo-VIN	VIN=-14.5~-27V, Io=40mA		36	250	mV
Load Regulation	Vo-Io	VIN=-19V, Io=1~100mA		16	100	mV
Quiescent current	Iq	VIN=-19V, Io=40mA		3.5	6.0	mA
Ripple Rejection	RR	VIN=-15~-25V, Io=40mA, Ein=1Vp-p, f=190Hz	37	64		dB
Output Noise Voltage	VNO	VIN=-19V, BW=10Hz~100kHz, Io=40mA		210		μV

## UTC79L15 ELECTRICAL CHARACTERISTICS

(Tj=25°C, C1=0.33μF, Co=0.1μF, unless otherwise specified)

PARAMETER	SYMBOL	TEST CONDITIONS	MIN	TYP	MAX	UNIT
Output Voltage	Vo	VIN=-23V, Io=40mA	-14.4	-15.0	-15.6	V
Line Regulation	Vo-VIN	VIN=-17.5~-30V, Io=40mA		45	300	mV
Load Regulation	Vo-Io	VIN=-23V, Io=1~100mA		20	150	mV
Quiescent current	Iq	VIN=-23V, Io=40mA		3.5	6.0	mA
Ripple Rejection	RR	VIN=-18.5~-28.5V, Io=40mA, Ein=1Vp-p, f=230Hz	34	63		dB
Output Noise Voltage	VNO	VIN=-23V, BW=10Hz~100kHz, Io=40mA		340		μV

## UTC79L18 ELECTRICAL CHARACTERISTICS

(Tj=25°C, C1=0.33μF, Co=0.1μF, unless otherwise specified)

PARAMETER	SYMBOL	TEST CONDITIONS	MIN	TYP	MAX	UNIT
Output Voltage	Vo	VIN=-27V, Io=40mA	-17.28	-18.0	-18.72	V
Line Regulation	Vo-VIN	VIN=-20.5~-33V, Io=40mA		54	300	mV
Load Regulation	Vo-Io	VIN=-27V, Io=1~100mA		23	170	mV
Quiescent current	Iq	VIN=-27V, Io=40mA		3.5	6.0	mA
Ripple Rejection	RR	VIN=-23~-33V, Io=40mA, Ein=1Vp-p, f=270Hz	33	60		dB
Output Noise Voltage	VNO	VIN=-27V, BW=10Hz~100kHz, Io=40mA		410		μV

# UTC79LXX LINEAR INTEGRATED CIRCUIT

## UTC79L24 ELECTRICAL CHARACTERISTICS

( $T_j=25^{\circ}\text{C}$ ,  $C_1=0.33\mu\text{F}$ ,  $C_o=0.1\mu\text{F}$ , unless otherwise specified)

PARAMETER	SYMBOL	TEST CONDITIONS	MIN	TYP	MAX	UNIT
Output Voltage	$V_o$	$V_{IN}=-33\text{V}$ , $I_o=40\text{mA}$	-23.04	-24.0	-24.96	V
Line Regulation	$V_o-V_{IN}$	$V_{IN}=-27\sim-38\text{V}$ , $I_o=40\text{mA}$		72	350	mV
Load Regulation	$V_o-I_o$	$V_{IN}=-33\text{V}$ , $I_o=1\sim 100\text{mA}$		30	200	mV
Quiescent current	$I_Q$	$V_{IN}=-33\text{V}$ , $I_o=40\text{mA}$		3.5	6.0	mA
Ripple Rejection	RR	$V_{IN}=-29\sim-35\text{V}$ , $I_o=40\text{mA}$ , $E_{in}=1\text{Vp-p}$ , $f=330\text{Hz}$	31	55		dB
Output Noise Voltage	$V_{NO}$	$V_{IN}=-33\text{V}$ , $BW=10\text{Hz}\sim 100\text{kHz}$ , $I_o=40\text{mA}$		550		$\mu\text{V}$

## APPLICATION CIRCUIT

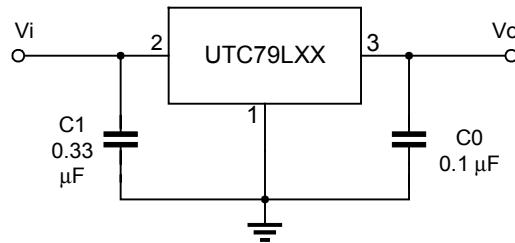

# UTC79LXX LINEAR INTEGRATED CIRCUIT

## TYPICAL PERFORMANCE CHARACTERISTICS

Fig.1 Power dissipation vs. ambient temperature

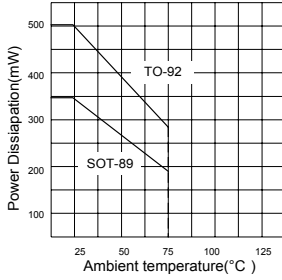

Fig.2 Input Voltage vs. Output Voltage

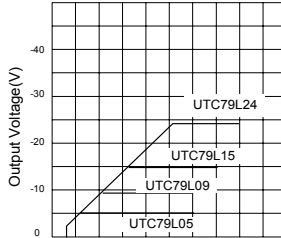

Fig.3 Load Characteristics (Tj=25°C)

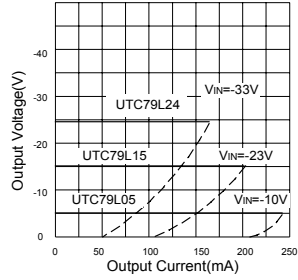

Fig.4 Short Circuit Current (Tj=25°C)

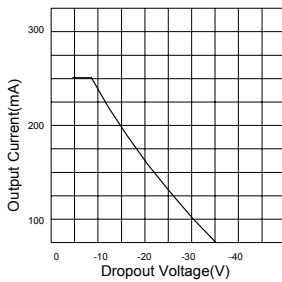

Fig.5 Output Voltage vs. Junction temperature

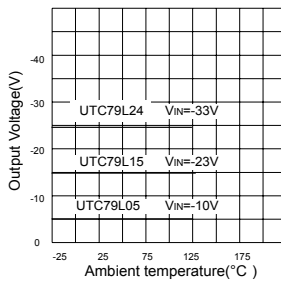

Fig.6 Output Voltage vs. ambient temperature

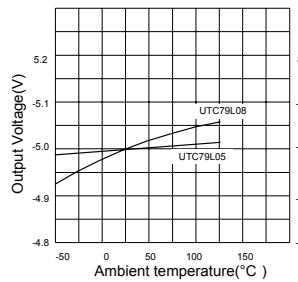

Fig.7 UTC79L05 Dropout Characteristics (Tj=25°C)

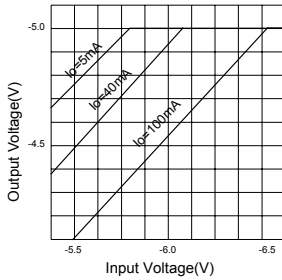

Fig.8 UTC79L08 Dropout Characteristics (Tj=25°C)

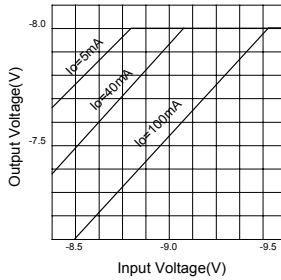

Fig.9 Current vs. Input Voltage (Io=0mA, Tj=25°C)

