

## 1.5°C ACCURATE PROGRAMMABLE DIGITAL TEMPERATURE SENSORS WITH SPI™ INTERFACE

### FEATURES

- **Digital Output: SPI-Compatible Interface**
- **Programmable Resolution: 9 to 12 Bits + Sign**
- **Accuracy: ±1.5°C from -25°C to 85°C (max)  
±2.0°C from -55°C to 125°C (max)**
- **Low Quiescent Current: 50 µA**
- **Wide Supply Range: 2.7 V to 5.5 V**
- **Tiny SOT23-6 Package**
- **Operation to 150°C**
- **Programmable High/Low Setpoints**

### APPLICATIONS

- **Power-Supply Temperature Monitoring**
- **Computer Peripheral Thermal Protection**
- **Notebook Computers**
- **Cell Phones**
- **Battery Management**
- **Office Machines**
- **Thermostat Controls**
- **Environmental Monitoring and HVAC**
- **Electromechanical Device Temperature**

### SUPPORTS DEFENSE, AEROSPACE, AND MEDICAL APPLICATIONS

- **Controlled Baseline**
- **One Assembly/Test Site**
- **One Fabrication Site**
- **Available in Military (-55°C/125°C)  
Temperature Range<sup>(1)</sup>**
- **Extended Product Life Cycle**
- **Extended Product-Change Notification**
- **Product Traceability**

(1) Additional temperature ranges are available - contact factory

### DESCRIPTION

The TMP122 is an SPI-compatible temperature sensor available in an SOT23-6 package. Requiring only a pull-up resistor for complete function, the TMP122 temperature sensor is capable of measuring temperatures within 2°C of accuracy over a temperature range of -55°C to 125°C, with operation up to 150°C. Programmable resolution, programmable set points and shut down function provide versatility for any application. Low supply current and a supply range from 2.7 V to 5.5 V make the TMP122 an excellent candidate for low-power applications.

The TMP122 is ideal for extended thermal measurement in a variety of communication, computer, consumer, environmental, industrial, and instrumentation applications.

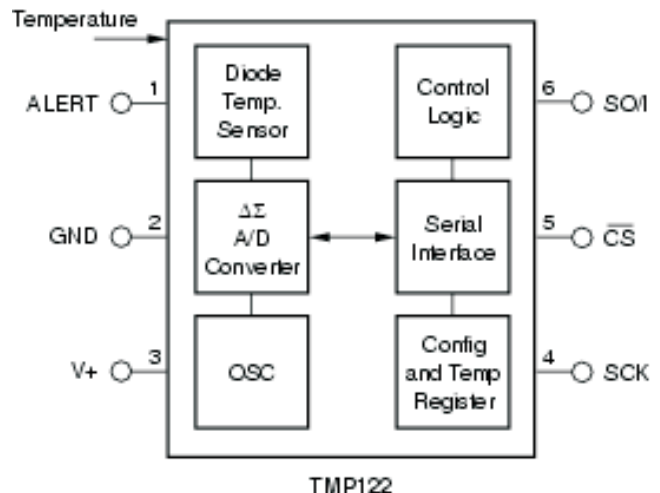

Please be aware that an important notice concerning availability, standard warranty, and use in critical applications of Texas Instruments semiconductor products and disclaimers thereto appears at the end of this data sheet.

SPI is a trademark of Motorola.



This integrated circuit can be damaged by ESD. Texas Instruments recommends that all integrated circuits be handled with appropriate precautions. Failure to observe proper handling and installation procedures can cause damage.

ESD damage can range from subtle performance degradation to complete device failure. Precision integrated circuits may be more susceptible to damage because very small parametric changes could cause the device not to meet its published specifications.

**ORDERING INFORMATION<sup>(1)</sup>**

T <sub>A</sub>	PACKAGE <sup>(2)</sup>		ORDERABLE PART NUMBER	TOP-SIDE MARKING
-55°C to 125°C	SOT23-6	Tape and reel of 250	TMP122AMDBVTEP	122E

- (1) For the most current package and ordering information, see the Package Option Addendum at the end of this document, or see the TI web site at [www.ti.com](http://www.ti.com).
- (2) Package drawings, thermal data, and symbolization are available at [www.ti.com/packaging](http://www.ti.com/packaging).

**ABSOLUTE MAXIMUM RATINGS**

over operating free-air temperature range (unless otherwise noted)

		VALUE	UNIT
V+	Power supply	7	V
V <sub>I</sub>	Input voltage	-0.3 to 7	V
	Inout current	10	mA
	Operating temperature range	-55 to 150	°C
	Storage temperature range	-60 to 150	°C
T <sub>J</sub> (max)	Junction temperature	150	°C
	Lead temperature (soldering)	300	°C

**PIN CONFIGURATION**

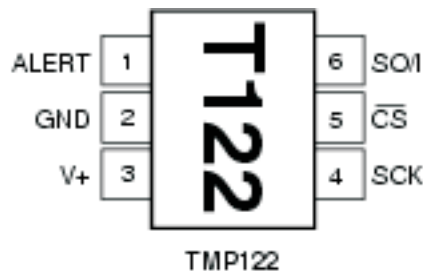

**ELECTRICAL CHARACTERISTICS**

over operating free-air temperature range (unless otherwise noted)

PARAMETER		TEST CONDITIONS	MIN	TYP	MAX	UNIT	
Temperature input	Range		-55		125	°C	
	Accuracy (temperature error)	-25°C to 85°C		±0.5	±1.5	°C	
		-55°C to 125°C		±1.0	±2.0		
		-55°C to 150°C		±1.5			
	vs supply			0.1		°C/V	
Resolution <sup>(1)</sup>	Selectable		±0.0625		°C		
Digital input/output	V <sub>IH</sub>		0.7 (V+)			V	
	V <sub>IL</sub>				0.3 (V+)	V	
	Input current, SO/I, SCK, $\overline{CS}$	0 V ≤ V <sub>IN</sub> ≤ V+			±1	μA	
	V <sub>OL</sub> SO/I	I <sub>SINK</sub> = 3mA			0.4	V	
	V <sub>OH</sub> SO/I	I <sub>SOURCE</sub> = 2mA	(V+) - 0.4			V	
	V <sub>OL</sub> ALERT	I <sub>SINK</sub> = 4mA			0.4	V	
	Leakage current ALERT	0 V ≤ V <sub>IN</sub> ≤ 6 V			±1	μA	
	Input capacitance, SO/I, SCK, $\overline{CS}$ , ALERT				2.5	pF	
	Resolution	Selectable		9 to 12 + sign		bits	
	Conversion time		9 bit + sign		30	40	ms
			10 bit + sign		60	80	
11 bit + sign				120	160		
12 bit + sign				240	320		
Power supply	Operating range		2.7		5.5	V	
	Quiescent current I <sub>Q</sub>	Serial bus inactive		50	75	μA	
	Shutdown current I <sub>SD</sub>	Serial bus inactive		0.1	1		
Temperature range	Specified range		-55		125	°C	
	Operating range		-55		150		
	Storage range		-60		150		
	Thermal resistance, θ <sub>JA</sub>	SOT23-6 surface-mount			200	°C/W	

(1) Specified for 12-bit resolution.

**TYPICAL CHARACTERISTICS**

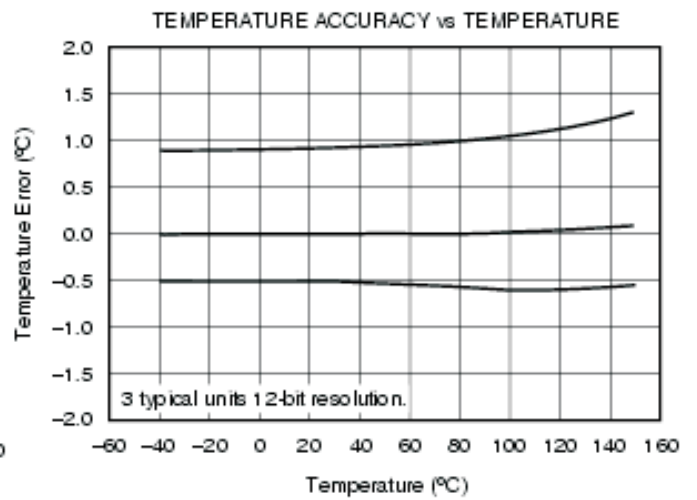
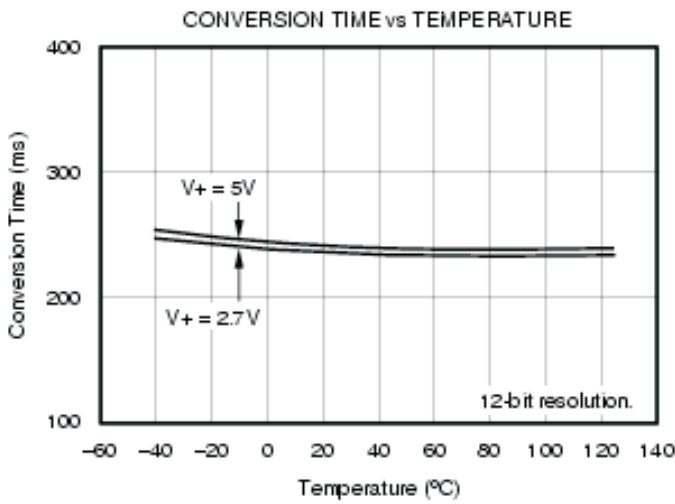
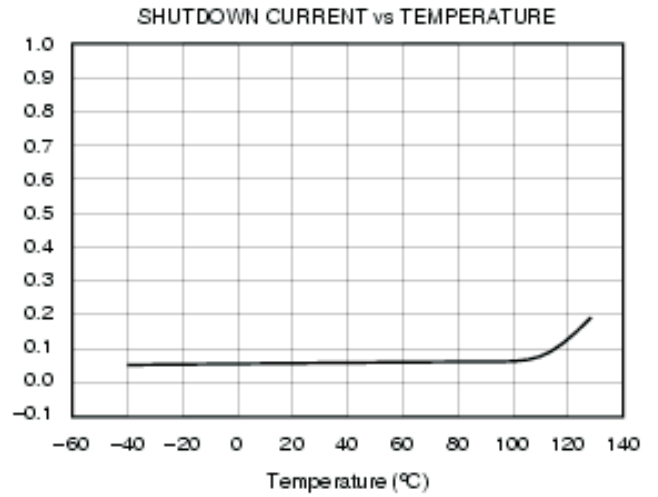
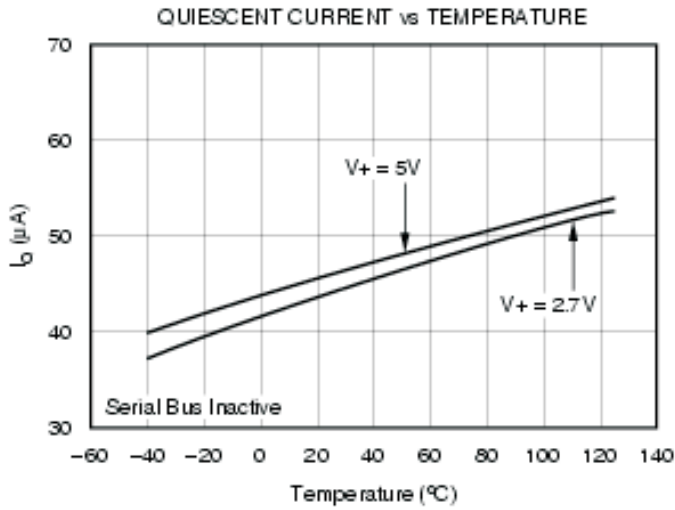

## APPLICATION INFORMATION

The TMP122 digital temperature sensor is optimal for thermal management and thermal protection applications. The TMP122 is SPI interface-compatible and specified for a temperature range of -55°C to 125°C.

The TMP122 requires minimal external components for operation, needing only a pullup resistor on the ALERT pin and a bypass capacitor on the supply. Bypass capacitors of 0.1  $\mu\text{F}$  is recommended. Figure 1 shows typical connections for the TMP122.

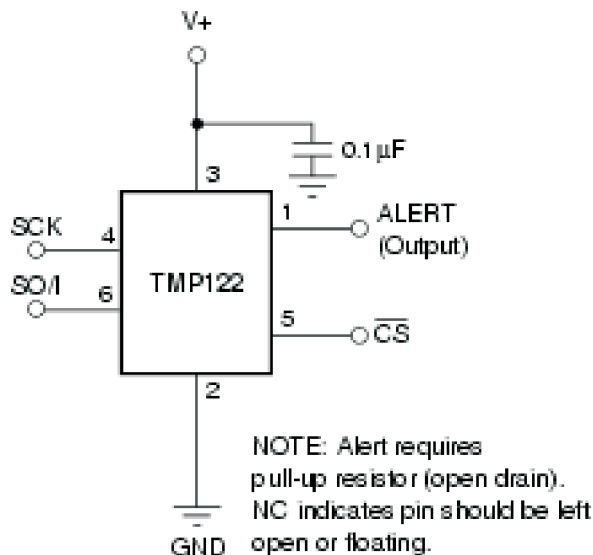

Figure 1. Typical Connections

To maintain accuracy in applications requiring air or surface temperature measurement, care should be taken to isolate the package and leads from ambient air temperature.

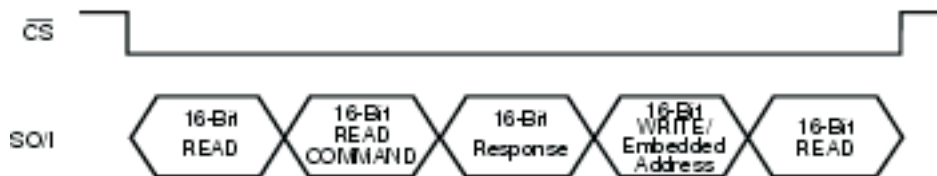

Figure 2. Multiple Command Sequence

## COMMUNICATING WITH THE TMP122

The TMP122 converts continuously. If  $\overline{\text{CS}}$  is brought low during a conversion the conversion process continues, but the last completed conversion is available at the output register. Communication with the TMP122 is initiated by pulling CS low. The first 16 clocks of data transfer will return temperature data from the temperature sensors. The 16-bit data word is clocked out sign bit first, followed by the MSB. Any portion of the 16-bit word may be read before raising CS. If the user wishes to continue with CS low, the following 16 clocks transfer in a READ or WRITE command. READ and WRITE commands are described in Table 1 and Table 2.

The READ command contains an embedded address in bits D4 and D3 to identify which register to read. Bits D4 and D3 are internally registered and will hold their value following a READ command until an entire 16-bit read is completed by the user. The completion of the 16-bit READ acknowledges that the READ command has been completed. If the user issues a READ command and then raises CS with less than 16 subsequent clocks, the data from that register will be available at the next fall of CS. The registered READ address will remain in effect until a full 16 clocks have been received. After the completion of a 16-bit READ from the part, the READ address is reset to return data from the Temperature Register. A WRITE command to a register will not change the READ address registered. For further discussion on the READ address register, see the *Read Address Register* section.

Multiple commands may be strung together as illustrated in Figure 2. The TMP122 accepts commands alternating with 16-bit response data. On lowering  $\overline{CS}$ , the part always responds with a READ from the address location indicated by the READ address register. If the next command is a READ command then data is returned from the address specified by the READ command with the 16th clock resetting the READ address register to the default temperature register. The TMP122 then expects a 16-bit command. If the command is a WRITE command, then the 16 clocks following the command will again return temperature data.

Figure 3, Figure 4, Figure 5, and Figure 6 detail the communication sequences.

**Table 1. READ Command**

READ Command	D15	D14	D13	D12	D11	D10	D9	D8	D7	D6	D5	D4	D3	D2	D1	D0
Temperature	1	0	0	0	0	0	0	0	0	0	0	0	0	0	0	0
Configuration register	1	0	0	0	0	0	0	0	0	0	0	0	1	0	0	0
Low temperature threshold	1	0	0	0	0	0	0	0	0	0	0	1	0	0	0	0
High temperature threshold	1	0	0	0	0	0	0	0	0	0	0	1	1	0	0	0

**Table 2. WRITE Command**

WRITE Command	D15	D14	D13	D12	D11	D10	D9	D8	D7	D6	D5	D4	D3	D2	D1	D0
Temperature	0	0	0	0	D1	D0	R1	R0	F1	F0	POL	TM1	TM0	0	1	0
Low temperature threshold	T12	T11	T10	T9	T8	T7	T6	T5	T4	T3	T2	T1	T0	1	0	0
High temperature threshold	T12	T11	T10	T9	T8	T7	T6	T5	T4	T3	T2	T1	T0	1	1	0
Shutdown command	x	x	x	x	x	x	x	x	1	1	1	1	1	1	1	1

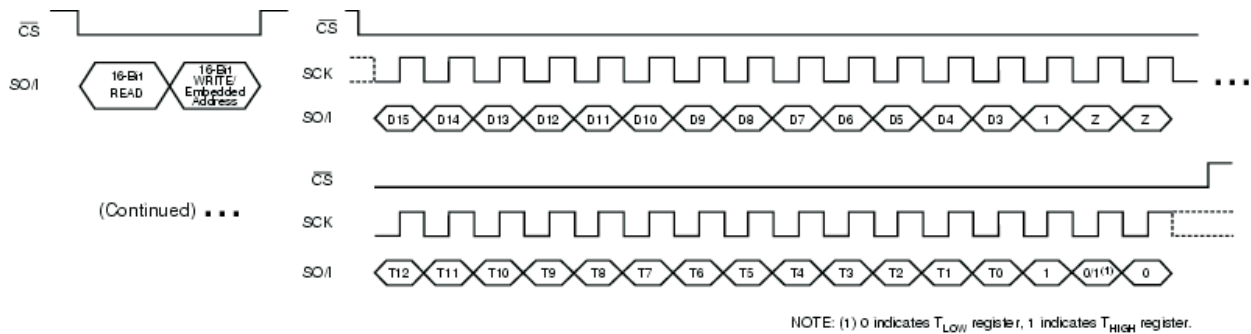

**Figure 3. READ followed by WRITE Command to  $T_{LOW}/T_{HIGH}$  Register**

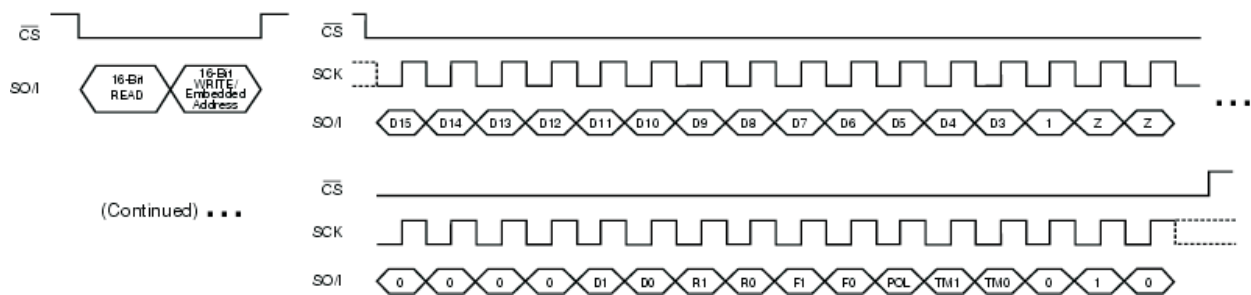

**Figure 4. READ followed by WRITE Command to Configuration Register**

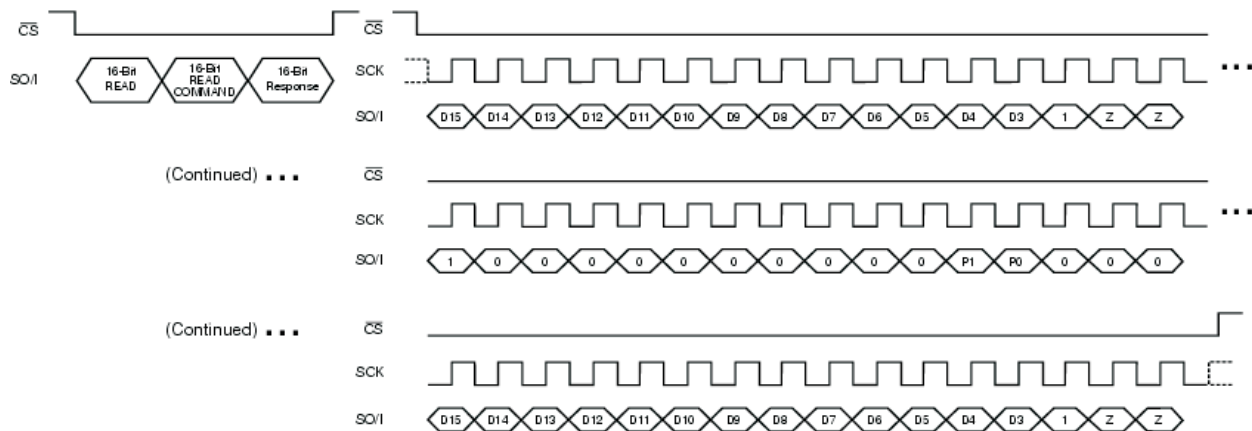

Figure 5. READ followed by READ Command and Response

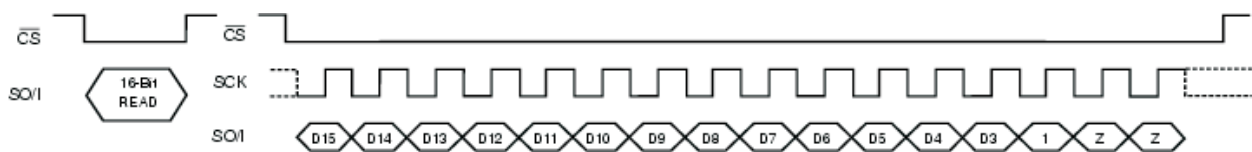

Figure 6. Data READ

## READ ADDRESS REGISTER

Figure 7 shows the internal register structure of the TMP122/TMP124. Table III describes the addresses of the registers available. The READ address register uses the two bits to identify which of the data registers should respond to a read command. Following a complete 16-bit read, the READ address register is reset to the default power-up state of P1/P0 equal 0/0.

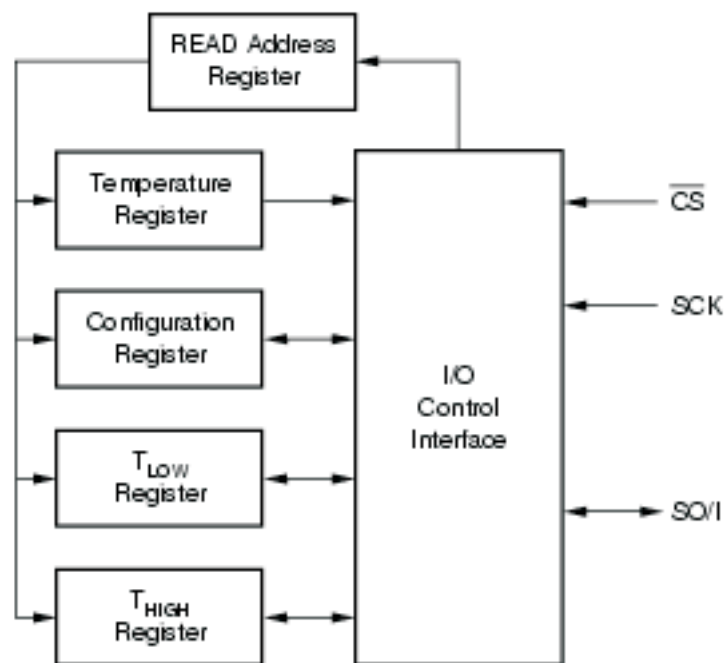

Figure 7. Internal Register Structure

**Table 3. Pointer Addresses**

P1	P0	REGISTER
0	0	Temperature Register (READ only)
0	1	Configuration Register (READ/WRITE)
1	0	T <sub>LOW</sub> Register (READ/WRITE)
1	1	T <sub>HIGH</sub> Register (READ/WRITE)

## TEMPERATURE REGISTER

The Temperature Register of the TMP122 is a 16-bit, signed read-only register that stores the output of the most recent conversion. The TMP122 is specified for the temperature range of -55°C to 125°C with operation from -55°C to 150°C. Up to 16 bits can be read to obtain data and are described in Table 4. The first 13 bits are used to indicate temperature where bit D2 is 1, and D1, D0 are in a high impedance state. Data format for temperature is summarized in Table 5. Following power-up or reset, the Temperature Register will read 0°C until the first conversion is complete.

**Table 4. Temperature Register**

D15	D14	D13	D12	D11	D10	D9	D8	D7	D6	D5	D4	D3	D2	D1	D0
T12	T11	T10	T9	T8	T7	T6	T5	T4	T3	T2	T1	T0	1	Z	Z

**Table 5. Temperature Data Format**

TEMPERATURE (°c)	DIGITAL OUTPUT <sup>(1)</sup> (BINARY)	HEX
150	0100 1011 0000 0111	4B07
125	0011 1110 1000 0111	3E87
25	0000 1100 1000 0111	0C87
0.0625	0000 0000 0000 1111	000F
0	0000 0000 0000 0111	0007
-0.0625	1111 1111 1111 1111	FFFF
-25	1111 0011 1000 0111	F387
-55	1110 0100 1000 0111	E487

(1) The last two bits are high impedance and are shown as 11 in the table.

The user can obtain 9, 10, 11, or 12 bits of resolution by addressing the Configuration Register and setting the resolution bits accordingly. For 9-, 10-, or 11-bit resolution, the most significant bits in the Temperature Register are used with the unused LSBs set to zero.

## CONFIGURATION REGISTER

The Configuration Register is a 16-bit read/write register used to store bits that control the operational modes of the temperature sensor. Read/write operations are performed MSB first. The format of the Configuration Register for the TMP122 is shown in Table 6, followed by a break-down of the register bits. The power-up/reset value of the Configuration Register bits R1/R0 equal 1/1, all other bits equal zero.

**Table 6. Configuration Register**

D15	D14	D13	D12	D11	D10	D9	D8	D7	D6	D5	D4	D3	D2	D1	D0
0	0	0	0	D1	D0	R1	R0	F1	F0	POL	TM1	TM0	0	1	0

## SHUTDOWN MODE (SD)

The Shutdown Mode of the TMP122 can be used to shut down all device circuitry except the serial interface. Shutdown mode occurs when the last 8 bits of the WRITE command are equal to 1, and will occur once the current conversion is completed, reducing current consumption to less than 1 µA. To take the part out of shutdown, send any command or pattern after the 16-bit read with the last 8 bits not equal to one. Power on default is in active mode.



## THERMOSTAT MODE (TM1/TM0)

The Thermostat Mode bits of the TMP122 indicate to the device whether to operate in Comparator Mode, Interrupt Mode or Interrupt Comparator Mode. For more information on Comparator and Interrupt Mode, see text HIGH and LOW limit registers. The bit assignments for thermostat mode are described in [Table 7](#). Power on default is comparator mode.

**Table 7. Mode Settings**

TM1	TM0	MODE OF OPERATION
0	0	Comparator mode
0	1	Interrupt mode
1	0	Interrupt comparator mode
1	1	Reserved

## POLARITY (POL)

The Polarity Bit of the TMP122 adjusts the polarity of the ALERT pin output. By default, POL = 0 and the ALERT pin will be active LOW, as shown in [Figure 8](#). For POL = 1 the ALERT Pin will be active HIGH, and the state of the ALERT Pin is inverted.

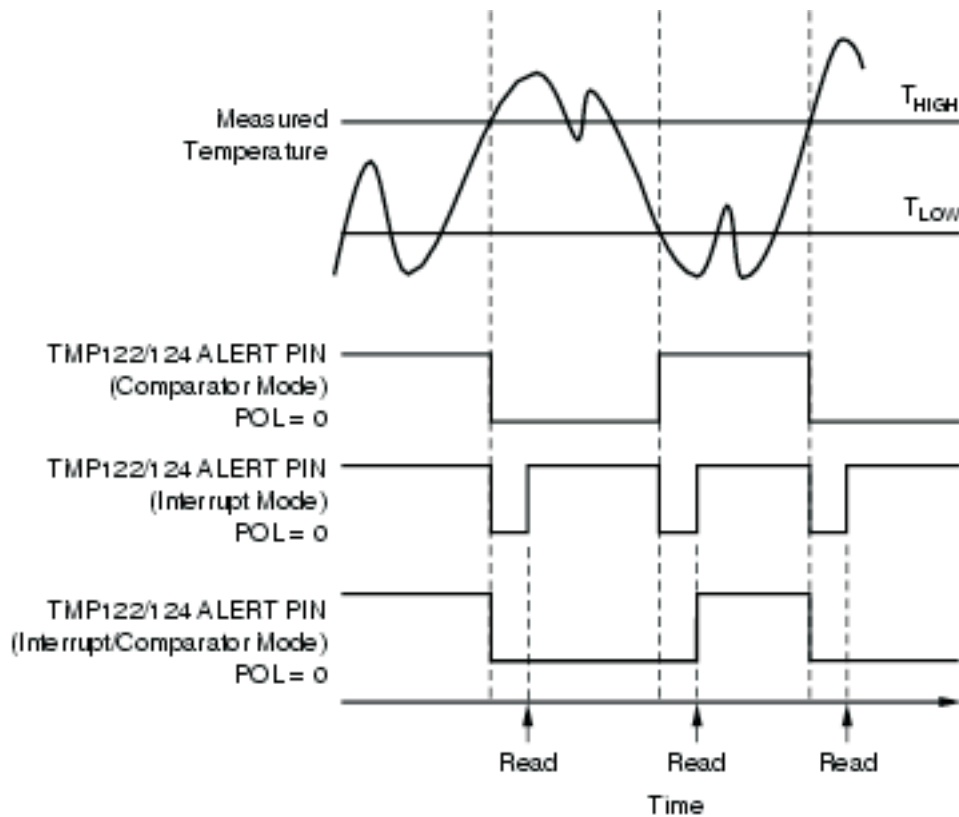

**Figure 8. ALERT Output Transfer Function Diagrams**

## FAULT QUEUE (F1/F0)

A fault condition occurs when the measured temperature exceeds the limits set in the  $T_{HIGH}$  and  $T_{LOW}$  registers. The Fault Queue is provided to prevent a false alert due to environmental noise and requires consecutive fault measurements to trigger the alert function of the TMP122. [Table 8](#) defines the number of consecutive faults required to trigger a consecutive alert condition. Power-on default for F1/F0 is 0/0.

**Table 8. Fault Settings**

F1	F0	CONSECUTIVE FAULTS
0	0	1
0	1	2
1	0	4
1	1	6

### HIGH AND LOW LIMIT REGISTERS

In Comparator Mode (TM1/TM0 = 0/0), the ALERT Pin of the TMP122 becomes active when the temperature equals or exceeds the value in T<sub>HIGH</sub> and generates a consecutive number of faults according to fault bits F1 and F0. The ALERT pin will remain active until the temperature falls below the indicated T<sub>LOW</sub> value for the same number of faults.

In Interrupt Mode (TM1/TM0 = 0/1) the ALERT pin becomes active when the temperature equals or exceeds T<sub>HIGH</sub> for a consecutive number of fault conditions. The ALERT pin remains active until a read operation of any register occurs. The ALERT pin will also be cleared if the device is placed in Shutdown Mode. Once the ALERT pin is cleared, it will only become active again by the temperature falling below T<sub>LOW</sub>. When the temperature falls below T<sub>LOW</sub>, the ALERT pin becomes active and remains active until cleared by a read operation of any register. Once the ALERT pin is cleared, the above cycle will repeat with the ALERT pin becoming active when the temperature equals or exceeds T<sub>HIGH</sub>.

In Interrupt/Comparator Mode (TM1/TM0 = 1/0), the ALERT Pin of the TMP122 becomes active when the temperature equals or exceeds the value in T<sub>HIGH</sub> and generates a consecutive number of faults according to fault bits F1 and F0. The ALERT pin will remain active until the temperature falls below the indicated T<sub>LOW</sub> value for the same number of faults and a communication with the device has occurred after that point.

Operational modes are represented in [Figure 8](#). [Table 9](#) and [Table 10](#) describe the format for the T<sub>HIGH</sub> and T<sub>LOW</sub> registers. Power-up reset values for T<sub>HIGH</sub> and T<sub>LOW</sub> are: T<sub>HIGH</sub> = 80°C and T<sub>LOW</sub> = 75°C. The format of the data for T<sub>HIGH</sub> and T<sub>LOW</sub> is the same as for the Temperature Register. TABLE IX. T<sub>HIGH</sub> Register.

All 13 bits for the Temperature, T<sub>HIGH</sub>, and T<sub>LOW</sub> registers are used in the comparisons for the ALERT function for all converter resolutions. The three LSBs in T<sub>HIGH</sub> and T<sub>LOW</sub> can affect the ALERT output even if the converter is configured for 9-bit resolution.

**Table 9. T<sub>HIGH</sub> Register**

D15	D14	D13	D12	D11	D10	D9	D8	D7	D6	D5	D4	D3	D2	D1	D0
H12	H11	H10	H9	H8	H7	H6	H5	H4	H3	H2	H1	H0	1	1	0

**Table 10. T<sub>LOW</sub> Register**

D15	D14	D13	D12	D11	D10	D9	D8	D7	D6	D5	D4	D3	D2	D1	D0
L12	L11	L10	L9	L8	L7	L6	L5	L4	L3	L2	L1	L0	1	0	0

### CONVERTER RESOLUTION (R1/R0)

The Converter Resolution Bits control the resolution of the internal analog-to-digital (A/D) converter. This allows the user to maximize efficiency by programming for higher resolution or faster conversion time. [Table 11](#) identifies the resolution bits and the relationship between resolution and conversion time. The TMP122 has a default resolution of 12 bits.

**Table 11. Resolution**

R1	R2	RESOLUTION	CONVERSION TIME (TYPICAL)
0	0	9 bits (0.5°C) + sign	30 ms
0	1	10 bits (0.25°C) + sign	60 ms
1	0	11 bits (0.125°C) + sign	120 ms
1	1	12 bits (0.0625°C) + sign	240 ms

## DELAY TIME

The Delay Bits control the amount of time delay between each conversion. This feature allows the user to maximize power savings by eliminating unnecessary conversions, and minimizing current consumption. During active conversion the TMP122 typically requires 50  $\mu\text{A}$  of current for approximately 0.25s conversion time, and approximately 20  $\mu\text{A}$  for idle times between conversions. Delay settings are identified in Table 12 as conversion time and period, and are shown in Figure 9. Default power up is D1/D0 equal 0/0. Conversion time and conversion periods scale with resolution. Conversion period denotes time between conversion starts.

Table 12. Conversion Delay for 12-Bit Resolution

D1	D2	CONVERSION TIME	CONVERSION PERIOD
0	0	0.25 s	0.25 s
0	1	0.25 s	0.5 s
1	0	0.25 s	1 s
1	1	0.25 s	8 s

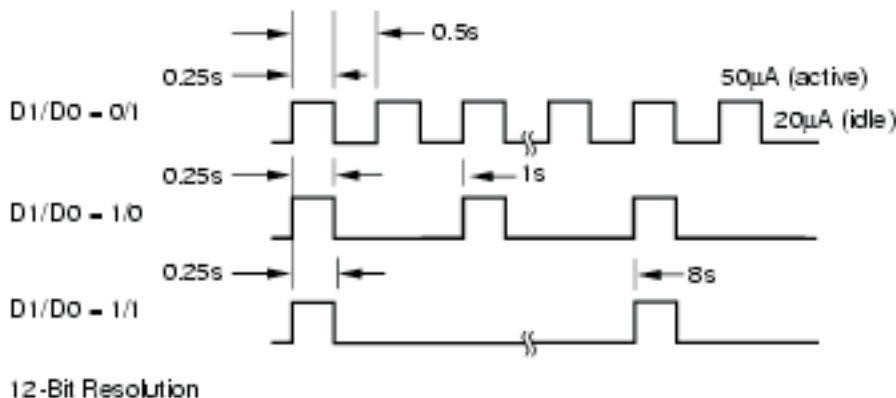

Figure 9. Conversion Time and Period Description

## TIMING DIAGRAMS

The TMP122 is SPI compatible. Figure 10 to Figure 12 describe the various timing parameters of the TMP122 with timing definitions in Table 13.

Table 13. Timing Description

PARAMETER	MIN	MAX	UNIT
$t_1$ SCK period	100		ns
$t_2$ Data in to rising edge SCK setup time	20		ns
$t_3$ SCK falling edge to output data delay		30	ns
$t_4$ SCK rising edge to input data hold time	20		ns
$t_5$ $\overline{\text{CS}}$ to rising edge SCK set-up time	40		ns
$t_6$ $\overline{\text{CS}}$ to output data delay		30	ns
$t_7$ $\overline{\text{CS}}$ rising edge to output high impedance		30	ns

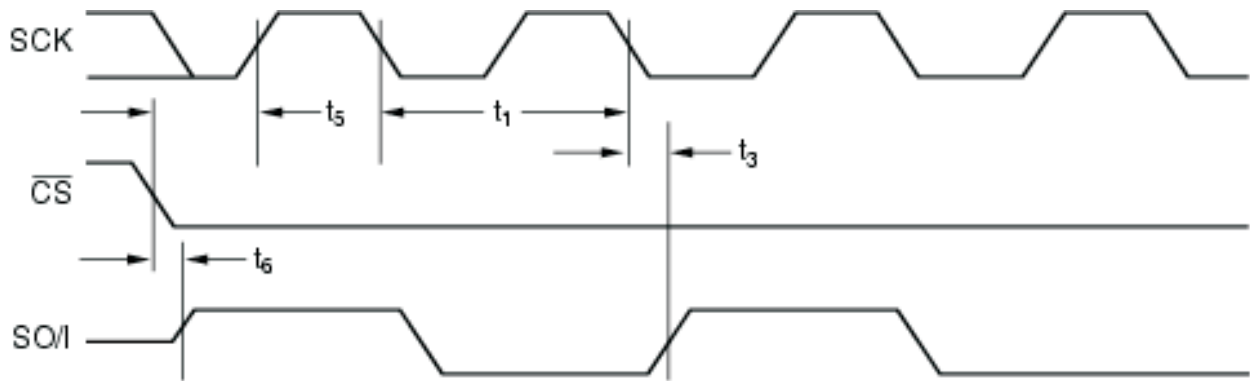

Figure 10. Output Data Timing Diagram

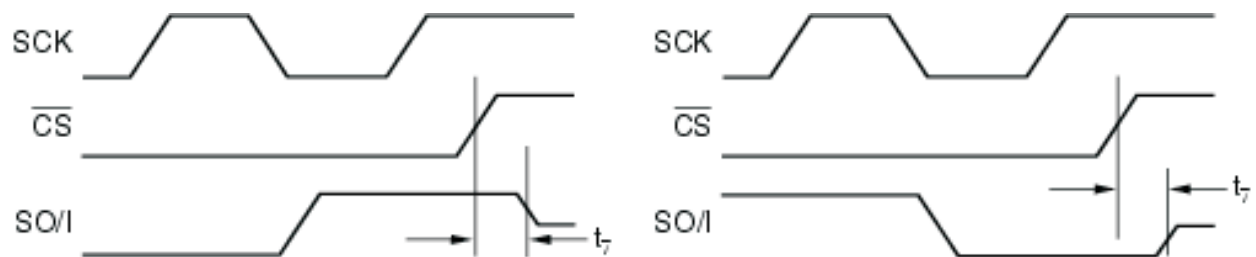

Figure 11. High Impedance Output Timing Diagram

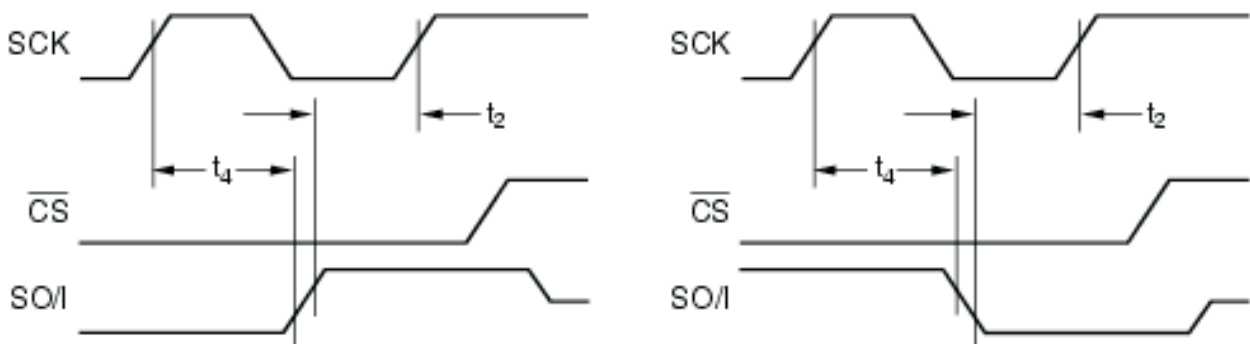

Figure 12. Input Data Timing Diagram

**PACKAGING INFORMATION**

Orderable Device	Status <sup>(1)</sup>	Package Type	Package Drawing	Pins	Package Qty	Eco Plan <sup>(2)</sup>	Lead/Ball Finish	MSL Peak Temp <sup>(3)</sup>
TMP122AMDBVTEP	ACTIVE	SOT-23	DBV	6	250	Green (RoHS & no Sb/Br)	CU NIPDAU	Level-2-260C-1 YEAR
V62/09607-01XE	ACTIVE	SOT-23	DBV	6	250	Green (RoHS & no Sb/Br)	CU NIPDAU	Level-2-260C-1 YEAR

<sup>(1)</sup> The marketing status values are defined as follows:

**ACTIVE:** Product device recommended for new designs.

**LIFEBUY:** TI has announced that the device will be discontinued, and a lifetime-buy period is in effect.

**NRND:** Not recommended for new designs. Device is in production to support existing customers, but TI does not recommend using this part in a new design.

**PREVIEW:** Device has been announced but is not in production. Samples may or may not be available.

**OBsolete:** TI has discontinued the production of the device.

<sup>(2)</sup> Eco Plan - The planned eco-friendly classification: Pb-Free (RoHS), Pb-Free (RoHS Exempt), or Green (RoHS & no Sb/Br) - please check <http://www.ti.com/productcontent> for the latest availability information and additional product content details.

**TBD:** The Pb-Free/Green conversion plan has not been defined.

**Pb-Free (RoHS):** TI's terms "Lead-Free" or "Pb-Free" mean semiconductor products that are compatible with the current RoHS requirements for all 6 substances, including the requirement that lead not exceed 0.1% by weight in homogeneous materials. Where designed to be soldered at high temperatures, TI Pb-Free products are suitable for use in specified lead-free processes.

**Pb-Free (RoHS Exempt):** This component has a RoHS exemption for either 1) lead-based flip-chip solder bumps used between the die and package, or 2) lead-based die adhesive used between the die and leadframe. The component is otherwise considered Pb-Free (RoHS compatible) as defined above.

**Green (RoHS & no Sb/Br):** TI defines "Green" to mean Pb-Free (RoHS compatible), and free of Bromine (Br) and Antimony (Sb) based flame retardants (Br or Sb do not exceed 0.1% by weight in homogeneous material)

<sup>(3)</sup> MSL, Peak Temp. -- The Moisture Sensitivity Level rating according to the JEDEC industry standard classifications, and peak solder temperature.

**Important Information and Disclaimer:** The information provided on this page represents TI's knowledge and belief as of the date that it is provided. TI bases its knowledge and belief on information provided by third parties, and makes no representation or warranty as to the accuracy of such information. Efforts are underway to better integrate information from third parties. TI has taken and continues to take reasonable steps to provide representative and accurate information but may not have conducted destructive testing or chemical analysis on incoming materials and chemicals. TI and TI suppliers consider certain information to be proprietary, and thus CAS numbers and other limited information may not be available for release.

In no event shall TI's liability arising out of such information exceed the total purchase price of the TI part(s) at issue in this document sold by TI to Customer on an annual basis.

**OTHER QUALIFIED VERSIONS OF TMP122-EP :**

- Catalog: [TMP122](#)

NOTE: Qualified Version Definitions:

- Catalog - TI's standard catalog product

## TAPE AND REEL INFORMATION

### REEL DIMENSIONS



### TAPE DIMENSIONS



A0	Dimension designed to accommodate the component width
B0	Dimension designed to accommodate the component length
K0	Dimension designed to accommodate the component thickness
W	Overall width of the carrier tape
P1	Pitch between successive cavity centers

### TAPE AND REEL INFORMATION

\*All dimensions are nominal

Device	Package Type	Package Drawing	Pins	SPQ	Reel Diameter (mm)	Reel Width W1 (mm)	A0 (mm)	B0 (mm)	K0 (mm)	P1 (mm)	W (mm)	Pin1 Quadrant
TMP122AMDBVTEP	SOT-23	DBV	6	250	180.0	8.4	3.2	3.1	1.39	4.0	8.0	Q3

**TAPE AND REEL BOX DIMENSIONS**



\*All dimensions are nominal

Device	Package Type	Package Drawing	Pins	SPQ	Length (mm)	Width (mm)	Height (mm)
TMP122AMDBVTEP	SOT-23	DBV	6	250	210.0	185.0	35.0

DBV (R-PDSO-G6)

PLASTIC SMALL-OUTLINE PACKAGE



- NOTES:
- A. All linear dimensions are in millimeters.
  - B. This drawing is subject to change without notice.
  - C. Body dimensions do not include mold flash or protrusion. Mold flash and protrusion shall not exceed 0.15 per side.
  - D. Leads 1,2,3 may be wider than leads 4,5,6 for package orientation.
- $\triangle E$  Falls within JEDEC MO-178 Variation AB, except minimum lead width.



DBV (R-PDSO-G6)

PLASTIC SMALL OUTLINE



- NOTES:
- A. All linear dimensions are in millimeters.
  - B. This drawing is subject to change without notice.
  - C. Customers should place a note on the circuit board fabrication drawing not to alter the center solder mask defined pad.
  - D. Publication IPC-7351 is recommended for alternate designs.
  - E. Laser cutting apertures with trapezoidal walls and also rounding corners will offer better paste release. Customers should contact their board assembly site for stencil design recommendations. Example stencil design based on a 50% volumetric metal load solder paste. Refer to IPC-7525 for other stencil recommendations.

## IMPORTANT NOTICE

Texas Instruments Incorporated and its subsidiaries (TI) reserve the right to make corrections, modifications, enhancements, improvements, and other changes to its products and services at any time and to discontinue any product or service without notice. Customers should obtain the latest relevant information before placing orders and should verify that such information is current and complete. All products are sold subject to TI's terms and conditions of sale supplied at the time of order acknowledgment.

TI warrants performance of its hardware products to the specifications applicable at the time of sale in accordance with TI's standard warranty. Testing and other quality control techniques are used to the extent TI deems necessary to support this warranty. Except where mandated by government requirements, testing of all parameters of each product is not necessarily performed.

TI assumes no liability for applications assistance or customer product design. Customers are responsible for their products and applications using TI components. To minimize the risks associated with customer products and applications, customers should provide adequate design and operating safeguards.

TI does not warrant or represent that any license, either express or implied, is granted under any TI patent right, copyright, mask work right, or other TI intellectual property right relating to any combination, machine, or process in which TI products or services are used. Information published by TI regarding third-party products or services does not constitute a license from TI to use such products or services or a warranty or endorsement thereof. Use of such information may require a license from a third party under the patents or other intellectual property of the third party, or a license from TI under the patents or other intellectual property of TI.

Reproduction of TI information in TI data books or data sheets is permissible only if reproduction is without alteration and is accompanied by all associated warranties, conditions, limitations, and notices. Reproduction of this information with alteration is an unfair and deceptive business practice. TI is not responsible or liable for such altered documentation. Information of third parties may be subject to additional restrictions.

Resale of TI products or services with statements different from or beyond the parameters stated by TI for that product or service voids all express and any implied warranties for the associated TI product or service and is an unfair and deceptive business practice. TI is not responsible or liable for any such statements.

TI products are not authorized for use in safety-critical applications (such as life support) where a failure of the TI product would reasonably be expected to cause severe personal injury or death, unless officers of the parties have executed an agreement specifically governing such use. Buyers represent that they have all necessary expertise in the safety and regulatory ramifications of their applications, and acknowledge and agree that they are solely responsible for all legal, regulatory and safety-related requirements concerning their products and any use of TI products in such safety-critical applications, notwithstanding any applications-related information or support that may be provided by TI. Further, Buyers must fully indemnify TI and its representatives against any damages arising out of the use of TI products in such safety-critical applications.

TI products are neither designed nor intended for use in military/aerospace applications or environments unless the TI products are specifically designated by TI as military-grade or "enhanced plastic." Only products designated by TI as military-grade meet military specifications. Buyers acknowledge and agree that any such use of TI products which TI has not designated as military-grade is solely at the Buyer's risk, and that they are solely responsible for compliance with all legal and regulatory requirements in connection with such use.

TI products are neither designed nor intended for use in automotive applications or environments unless the specific TI products are designated by TI as compliant with ISO/TS 16949 requirements. Buyers acknowledge and agree that, if they use any non-designated products in automotive applications, TI will not be responsible for any failure to meet such requirements.

Following are URLs where you can obtain information on other Texas Instruments products and application solutions:

### Products

Audio	<a href="http://www.ti.com/audio">www.ti.com/audio</a>
Amplifiers	<a href="http://amplifier.ti.com">amplifier.ti.com</a>
Data Converters	<a href="http://dataconverter.ti.com">dataconverter.ti.com</a>
DLP® Products	<a href="http://www.dlp.com">www.dlp.com</a>
DSP	<a href="http://dsp.ti.com">dsp.ti.com</a>
Clocks and Timers	<a href="http://www.ti.com/clocks">www.ti.com/clocks</a>
Interface	<a href="http://interface.ti.com">interface.ti.com</a>
Logic	<a href="http://logic.ti.com">logic.ti.com</a>
Power Mgmt	<a href="http://power.ti.com">power.ti.com</a>
Microcontrollers	<a href="http://microcontroller.ti.com">microcontroller.ti.com</a>
RFID	<a href="http://www.ti-rfid.com">www.ti-rfid.com</a>
OMAP Mobile Processors	<a href="http://www.ti.com/omap">www.ti.com/omap</a>
Wireless Connectivity	<a href="http://www.ti.com/wirelessconnectivity">www.ti.com/wirelessconnectivity</a>

### Applications

Communications and Telecom	<a href="http://www.ti.com/communications">www.ti.com/communications</a>
Computers and Peripherals	<a href="http://www.ti.com/computers">www.ti.com/computers</a>
Consumer Electronics	<a href="http://www.ti.com/consumer-apps">www.ti.com/consumer-apps</a>
Energy and Lighting	<a href="http://www.ti.com/energy">www.ti.com/energy</a>
Industrial	<a href="http://www.ti.com/industrial">www.ti.com/industrial</a>
Medical	<a href="http://www.ti.com/medical">www.ti.com/medical</a>
Security	<a href="http://www.ti.com/security">www.ti.com/security</a>
Space, Avionics and Defense	<a href="http://www.ti.com/space-avionics-defense">www.ti.com/space-avionics-defense</a>
Transportation and Automotive	<a href="http://www.ti.com/automotive">www.ti.com/automotive</a>
Video and Imaging	<a href="http://www.ti.com/video">www.ti.com/video</a>

TI E2E Community Home Page

[e2e.ti.com](http://e2e.ti.com)

Mailing Address: Texas Instruments, Post Office Box 655303, Dallas, Texas 75265  
Copyright © 2011, Texas Instruments Incorporated