

TLV5614-EP

2.7-V TO 5.5-V 12-BIT 3- μ s QUADRUPLE DIGITAL-TO-ANALOG CONVERTER WITH POWER DOWN

SGLS355 – JUNE 2006

- **Controlled Baseline**
 - One Assembly
 - One Test Site
 - One Fabrication Site
- **Extended Temperature Performance of –55°C to 125°C**
- **Enhanced Diminishing Manufacturing Sources (DMS) Support**
- **Enhanced Product-Change Notification**
- **Qualification Pedigree†**
- **Four 12-Bit Digital-to-Analog Converters (DACs)**
- **Programmable Settling Time of Either 3 μ s or 9 μ s (Typ)**
- **TMS320™ DSP Family, (Q)SPI™, and Microwire™ Compatible Serial Interface**
- **Internal Power-On Reset**
- **Low Power Consumption:**
 - 8 mW, Slow Mode – 5-V Supply**
 - 3.6 mW, Slow Mode – 3-V Supply**
- **Reference Input Buffer**
- **Voltage Output Range . . . 2× the Reference Input Voltage**
- **Monotonic Overtemperature**
- **Dual 2.7-V to 5.5-V Supply (Separate Digital and Analog Supplies)**
- **Hardware Power Down (10 nA)**
- **Software Power Down (10 nA)**
- **Simultaneous Update**

applications

- **Battery-Powered Test Instruments**
- **Digital Offset and Gain Adjustment**
- **Industrial Process Controls**
- **Machine and Motion Control Devices**
- **Communications**
- **Arbitrary Waveform Generation**

† Component qualification in accordance with JEDEC and industry standards to ensure reliable operation over an extended temperature range. This includes, but is not limited to, Highly Accelerated Stress Test (HAST) or biased 85/85, temperature cycle, autoclave or unbiased HAST, electromigration, bond intermetallic life, and mold compound life. Such qualification testing should not be viewed as justifying use of this component beyond specified performance and environmental limits.

description

The TLV5614 is a quadruple 12-bit voltage output digital-to-analog converter (DAC) with a flexible four-wire serial interface. The four-wire serial interface allows glueless interface to TMS320™ DSP family, SPI™, QSPI™, and Microwire™ serial ports. The TLV5614 is programmed with a 16-bit serial word comprised of a DAC address, individual DAC control bits, and a 12-bit DAC value. The device has provision for two supplies – one digital supply for the serial interface (via pins DV_{DD} and DGND), and one for the DACs, reference buffers, and output buffers (via pins AV_{DD} and AGND). Each supply is independent of the other and can be any value between 2.7 V and 5.5 V. The dual supplies allow a typical application where the DAC is controlled via a microprocessor operating on a 3-V supply (also used on pins DV_{DD} and DGND), with the DACs operating on a 5-V supply. The digital and analog supplies can be tied together.

**PW PACKAGE
(TOP VIEW)**

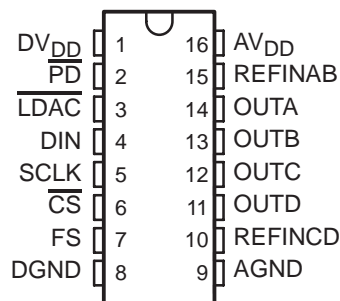

Please be aware that an important notice concerning availability, standard warranty, and use in critical applications of Texas Instruments semiconductor products and disclaimers thereto appears at the end of this data sheet.

TMS320 is a trademark of Texas Instruments.
All other trademarks are the property of their respective owners.

PRODUCTION DATA information is current as of publication date. Products conform to specifications per the terms of Texas Instruments standard warranty. Production processing does not necessarily include testing of all parameters.



POST OFFICE BOX 655303 • DALLAS, TEXAS 75265

Copyright © 2006, Texas Instruments Incorporated

TLV5614-EP

2.7-V TO 5.5-V 12-BIT 3- μ s QUADRUPLE DIGITAL-TO-ANALOG CONVERTER WITH POWER DOWN

SGLS355 – JUNE 2006

description (continued)

The resistor string output voltage is buffered by a 2 \times gain rail-to-rail output buffer. The buffer features a Class AB output stage to improve stability and reduce settling time. A rail-to-rail output stage and a power-down mode makes it ideal for single-voltage, battery-based applications. The settling time of the DAC is programmable to allow the designer to optimize speed versus power dissipation. The settling time is chosen by the control bits within the 16-bit serial input string. A high-impedance buffer is integrated on the REFINAB and REFINCD terminals to reduce the need for a low source-impedance drive to the terminal. REFINAB and REFINCD allow DAC A and B to have a different reference voltage than DAC C and D.

The TLV5614 is implemented with a CMOS process and is available in a 16-terminal TSSOP package. The TLV5614M is characterized for operation from -55°C to 125°C .

AVAILABLE OPTIONS

T _A	PACKAGE
	TSSOP (PW)
-55°C to 125°C	TLV5614MPWREP



POST OFFICE BOX 655303 • DALLAS, TEXAS 75265

TLV5614-EP
2.7-V TO 5.5-V 12-BIT 3- μ s QUADRUPLE DIGITAL-TO-ANALOG CONVERTER
WITH POWER DOWN

SGLS355 – JUNE 2006

Terminal Functions

TERMINAL NAME	NO.	I/O	DESCRIPTION
AGND	9		Analog ground
AV _{DD}	16		Analog supply
\overline{CS}	6	I	Chip select. This terminal is active low.
DGND	8		Digital ground
DIN	4	I	Serial data input
DV _{DD}	1		Digital supply
FS	7	I	Frame synchronization. The falling edge of the frame synchronization pulse indicates the start of a serial data frame shifted out to the TLV5614.
\overline{PD}	2	I	Power down. Powers down all DACs (overriding their individual power down settings) and all output stages. This terminal is active low.
\overline{LDAC}	3	I	Load DAC. When \overline{LDAC} is high, no DAC output updates occur when the input digital data is read into the serial interface. The DAC outputs are only updated when \overline{LDAC} is low.
REFINAB	15	I	Voltage reference input for DAC A and B
REFINCD	10	I	Voltage reference input for DAC C and D
SCLK	5	I	Serial clock input
OUTA	14	O	DAC A
OUTB	13	O	DAC B
OUTC	12	O	DAC C
OUTD	11	O	DAC D

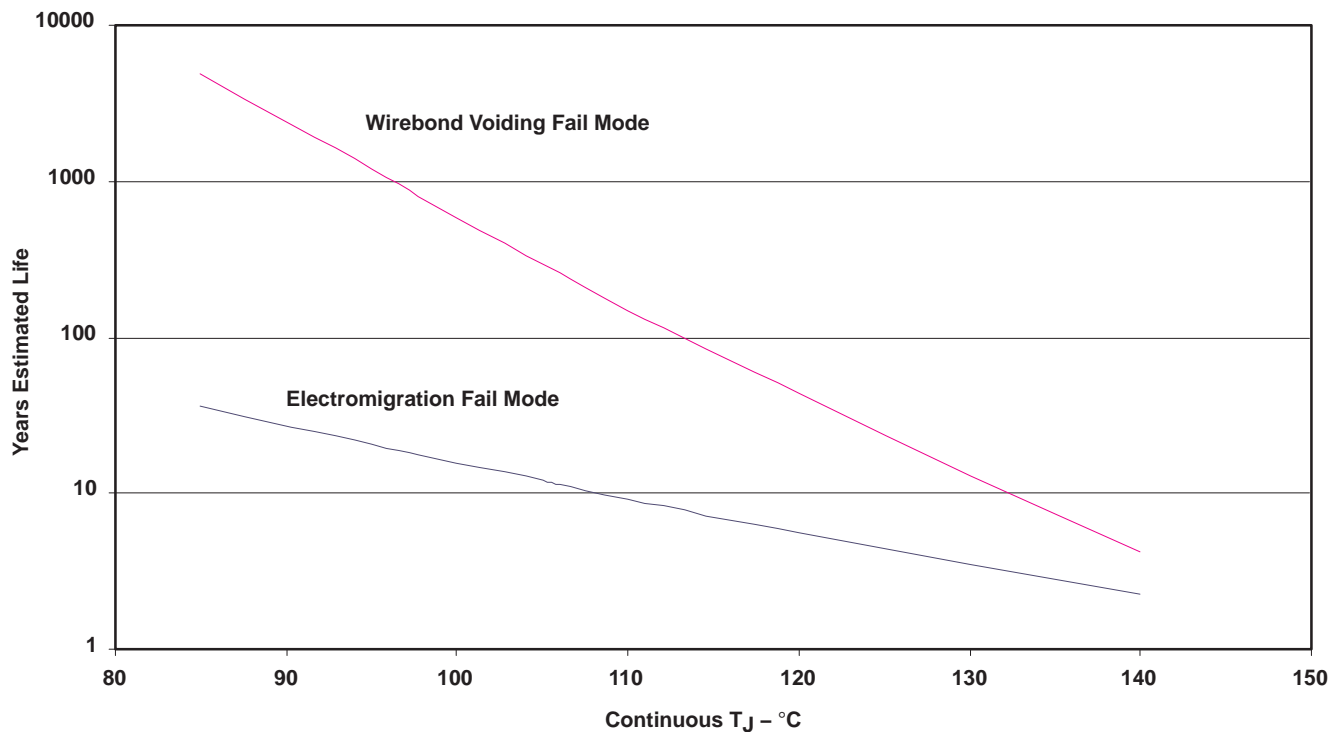

Figure 1. Operating Life Derating Chart



TLV5614-EP

2.7-V TO 5.5-V 12-BIT 3- μ s QUADRUPLE DIGITAL-TO-ANALOG CONVERTER WITH POWER DOWN

SGLS355 – JUNE 2006

absolute maximum ratings over operating free-air temperature range (unless otherwise noted)[†]

Supply voltage, (DV _{DD} , AV _{DD} to GND)	7 V
Supply voltage difference (AV _{DD} to DV _{DD})	–2.8 V to 2.8 V
Digital input voltage range	–0.3 V to DV _{DD} + 0.3 V
Reference input voltage range	–0.3 V to AV _{DD} + 0.3 V
Operating free-air temperature range, T _A	–55°C to 125°C
Storage temperature range, T _{stg}	–65°C to 150°C
Lead temperature 1,6 mm (1/16 in) from case for 10 s	260°C

[†] Stresses beyond those listed under “absolute maximum ratings” may cause permanent damage to the device. These are stress ratings only, and functional operation of the device at these or any other conditions beyond those indicated under “recommended operating conditions” is not implied. Exposure to absolute-maximum-rated conditions for extended periods may affect device reliability.

recommended operating conditions

		MIN	NOM	MAX	UNIT
Supply voltage, AV _{DD} , DV _{DD}	5-V supply	4.5	5	5.5	V
	3-V supply	2.7	3	3.3	
High-level digital input voltage, V _{IH}	DV _{DD} = 2.7 V	2			V
	DV _{DD} = 5.5 V	2.4			
Low-level digital input voltage, V _{IL}	DV _{DD} = 2.7 V	0.6			V
	DV _{DD} = 5.5 V	1			
Reference voltage, V _{ref} to REFINAB, REFINCD terminal	5-V supply, See Note 1	0	2.048	V _{DD} – 1.5	V
	3-V supply, See Note 1	0	1.024	V _{DD} – 1.5	
Load resistance, R _L		2	10		k Ω
Load capacitance, C _L				100	pF
Serial clock rate, SCLK				20	MHz
Operating free-air temperature		–55		125	°C/W
Package thermal resistance, junction to ambient, θ_{JA}			108.4		°C/W

NOTE 1: Voltages greater than AV_{DD}/2 cause output saturation for large DAC codes.



TLV5614-EP

2.7-V TO 5.5-V 12-BIT 3- μ s QUADRUPLE DIGITAL-TO-ANALOG CONVERTER WITH POWER DOWN

SGLS355 – JUNE 2006

electrical characteristics over recommended operating free-air temperature range, $V_{ref} = 2.048$ V, $AV_{DD} = DV_{DD} = 5$ V and $V_{ref} = 1.024$ V for $AV_{DD} = DV_{DD} = 3$ V (unless otherwise noted)

static DAC specifications

PARAMETER		TEST CONDITIONS	MIN	TYP	MAX	UNIT
Resolution			12			bits
Integral nonlinearity (INL), end point adjusted		See Note 1		± 1.5	± 4	LSB
Differential nonlinearity (DNL)		See Note 2		± 0.5	± 1	LSB
EZS	Zero-scale error (offset error at zero scale)	See Note 3			± 12	mV
Zero-scale error temperature coefficient		See Note 4		10		ppm/ $^{\circ}$ C
EG	Gain error	See Note 5			± 0.7	% of FS voltage
Gain-error temperature coefficient		See Note 6		10		ppm/ $^{\circ}$ C
PSRR	Power-supply rejection ratio	Zero scale	See Note 7 and Note 8		-80	dB
		Full scale			-80	dB

- NOTES:
1. The relative accuracy or integral nonlinearity (INL), sometimes referred to as linearity error, is the maximum deviation of the output from the line between zero and full scale excluding the effects of zero code and full-scale errors.
 2. The differential nonlinearity (DNL), sometimes referred to as differential error, is the difference between the measured and ideal 1-LSB amplitude change of any two adjacent codes. Monotonic means the output voltage changes in the same direction (or remains constant) as a change in the digital input code.
 3. Zero-scale error is the deviation from zero voltage output when the digital input code is zero.
 4. Zero-scale-error temperature coefficient is given by: $E_{ZS} TC = [E_{ZS}(T_{max}) - E_{ZS}(T_{min})] / V_{ref} \times 10^6 / (T_{max} - T_{min})$.
 5. Gain error is the deviation from the ideal output ($2 V_{ref} - 1$ LSB) with an output load of 10 k Ω , excluding the effects of the zero error.
 6. Gain temperature coefficient is given by: $E_G TC = [E_G(T_{max}) - E_G(T_{min})] / V_{ref} \times 10^6 / (T_{max} - T_{min})$.
 7. Zero-scale-error rejection ratio (EZS-RR) is measured by varying the AV_{DD} from 5 ± 0.5 V and 3 ± 0.3 V dc, and measuring the proportion of this signal imposed on the zero-code output voltage.
 8. Full-scale rejection ratio (EG-RR) is measured by varying the AV_{DD} from 5 ± 0.5 V and 3 ± 0.3 V dc and measuring the proportion of this signal imposed on the full-scale output voltage after subtracting the zero-scale change.

individual DAC output specifications

PARAMETER		TEST CONDITIONS	MIN	TYP	MAX	UNIT
V_O	Voltage output range	$R_L = 10$ k Ω	0		$AV_{DD} - 0.4$	V
Output load regulation accuracy		$R_L = 2$ k Ω vs 10 k Ω		0.1	0.25	% of FS voltage

reference inputs (REFINAB, REFINCD)

PARAMETER		TEST CONDITIONS	MIN	TYP	MAX	UNIT
V_I	Input voltage range	See Note 1	0		$AV_{DD} - 1.5$	V
R_I	Input resistance			10		M Ω
C_I	Input capacitance			5		pF
Reference feed through		REFIN = 1 V _{pp} at 1 kHz + 1.024 Vdc (see Note 2)			-75	dB
Reference input bandwidth		REFIN = 0.2 V _{pp} + 1.024-Vdc large signal	Slow	0.5		MHz
			Fast	1		

- NOTES:
1. Reference input voltages greater than $V_{DD}/2$ cause output saturation for large DAC codes.
 2. Reference feedthrough is measured at the DAC output, with an input code = 000 hex and a V_{ref} (REFINAB or REFINCD) input = 1.024 Vdc + 1 V_{pp} at 1 kHz.



TLV5614-EP

2.7-V TO 5.5-V 12-BIT 3- μ s QUADRUPLE DIGITAL-TO-ANALOG CONVERTER WITH POWER DOWN

SGLS355 – JUNE 2006

electrical characteristics over recommended operating free-air temperature range, $V_{ref} = 2.048$ V, $AV_{DD} = DV_{DD} = 5$ V and $V_{ref} = 1.024$ V for $AV_{DD} = DV_{DD} = 3$ V (unless otherwise noted) (continued)

digital inputs (\overline{DIN} , \overline{CS} , \overline{LDAC} , \overline{PD})

PARAMETER		TEST CONDITIONS	MIN	TYP	MAX	UNIT
I_{IH}	High-level digital input current	$V_I = V_{DD}$			± 1	μ A
I_{IL}	Low-level digital input current	$V_I = 0$ V			± 1	μ A
C_I	Input capacitance			3		pF

power supply

PARAMETER		TEST CONDITIONS		MIN	TYP	MAX	UNIT
I_{DD}	Power-supply current	5-V supply, No load, Clock running, All inputs 0 V or V_{DD}	Slow	1.6	2.4	mA	
			Fast	3.8	5.6		
		3-V supply, No load, Clock running, All inputs 0 V or DV_{DD}	Slow	1.2	1.8		
			Fast	3.2	4.8		
Power-down supply current (see Figure 13)				10		nA	

analog output dynamic performance

PARAMETER		TEST CONDITIONS		TYP	UNIT
SR	Output slew rate	$C_L = 100$ pF, $R_L = 10$ k Ω , $V_O = 10\%$ to 90% , $V_{ref} = 2.048$ V, 1024 V	Fast	5	V/ μ s
			Slow	1	V/ μ s
t_s	Output settling time	To ± 0.5 LSB, $C_L = 100$ pF, $R_L = 10$ k Ω , See Note 1	Fast	3	μ s
			Slow	9	
$t_{s(c)}$	Output settling time, code to code	To ± 0.5 LSB, $C_L = 100$ pF, $R_L = 10$ k Ω , See Note 2	Fast	1	μ s
			Slow	2	
Glitch energy		Code transition from 7FF to 800		10	nV-s
SNR	Signal-to-noise ratio	Sine wave generated by DAC, Reference voltage = 1.024 at 3 V and 2.048 at 5 V, $f_s = 400$ KSPS, $f_{OUT} = 1.1$ -kHz sine wave, $C_L = 100$ pF, $R_L = 10$ k Ω , BW = 20 kHz		74	dB
S/(N+D)	Signal-to-noise + distortion			66	dB
THD	Total harmonic distortion			-68	dB
SFDR	Spurious-free dynamic range			70	dB

- NOTES: 1. Settling time is the time for the output signal to remain within ± 0.5 LSB of the final measured value for a digital input code change of FFF hex to 080 hex for 080 hex to FFF hex.
2. Settling time is the time for the output signal to remain within ± 0.5 LSB of the final measured value for a digital input code change of one count.

TLV5614-EP
2.7-V TO 5.5-V 12-BIT 3- μ s QUADRUPLE DIGITAL-TO-ANALOG CONVERTER
WITH POWER DOWN

SGLS355 – JUNE 2006

electrical characteristics over recommended operating free-air temperature range, $V_{ref} = 2.048$ V, $AV_{DD} = DV_{DD} = 5$ V and $V_{ref} = 1.024$ V for $AV_{DD} = DV_{DD} = 3$ V (unless otherwise noted) (continued)

digital input timing requirements

		MIN	NOM	MAX	UNIT
$t_{su}(CS-FS)$	Setup time, \overline{CS} low before FS \downarrow	10			ns
$t_{su}(FS-CK)$	Setup time, FS low before first negative SCLK edge	8			ns
$t_{su}(C16-FS)$	Setup time, sixteenth negative SCLK edge after FS low on which bit D0 is sampled before rising edge of FS	10			ns
$t_{su}(C16-CS)$	Setup time. The first positive SCLK edge after D0 is sampled before \overline{CS} rising edge. If FS is used instead of the SCLK positive edge to update the DAC, then the setup time is between the FS rising edge and \overline{CS} rising edge.	10			ns
t_{wH}	Pulse duration, SCLK high	25			ns
t_{wL}	Pulse duration, SCLK low	25			ns
$t_{su}(D)$	Setup time, data ready before SCLK falling edge	8			ns
$t_h(D)$	Hold time, data held valid after SCLK falling edge	5			ns
$t_{wH}(FS)$	Pulse duration, FS high		60		ns

PARAMETER MEASUREMENT INFORMATION

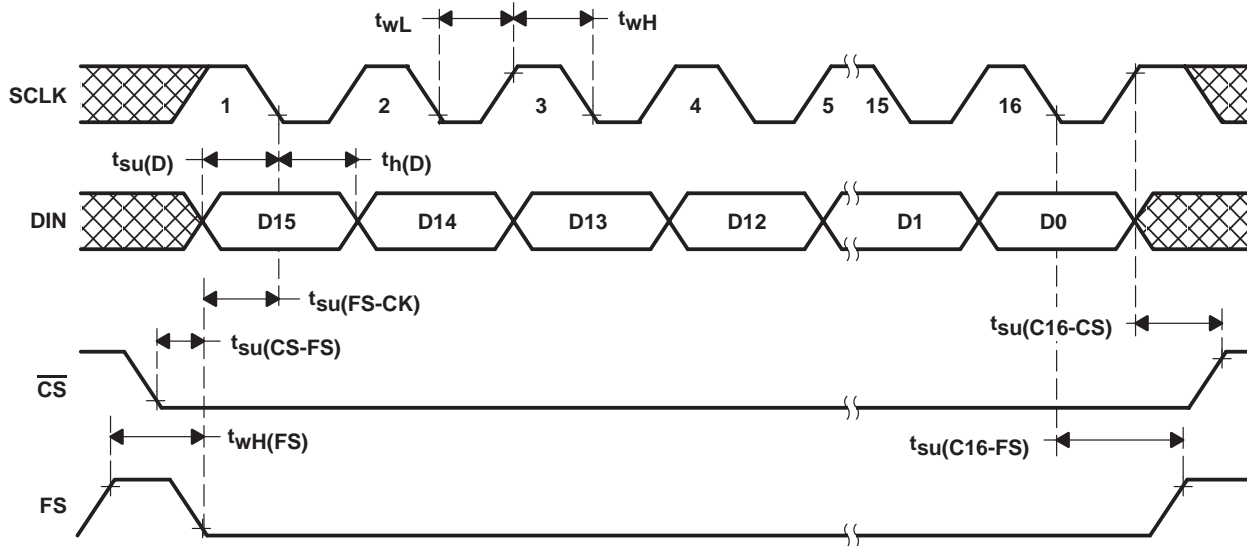
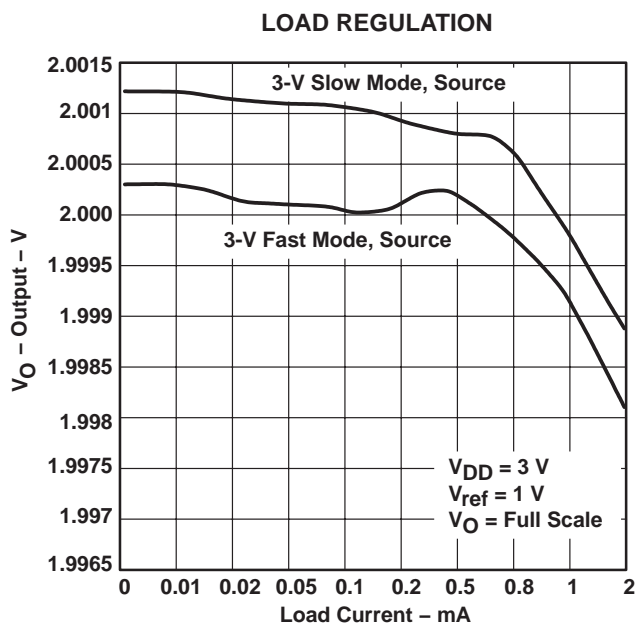
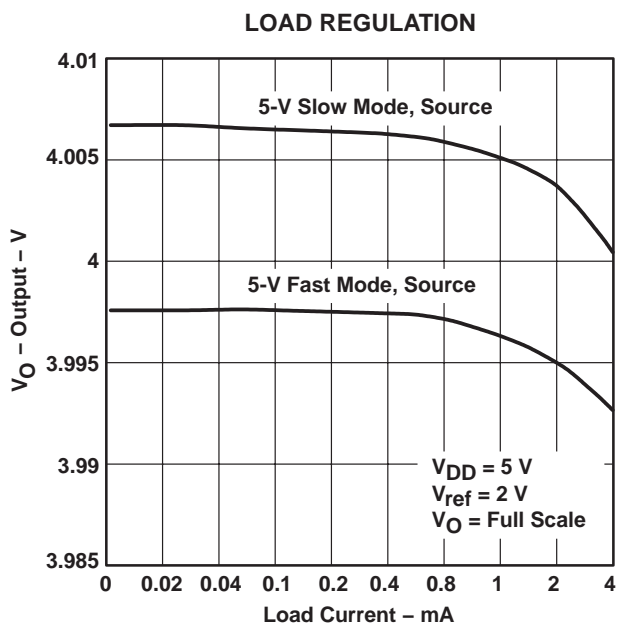
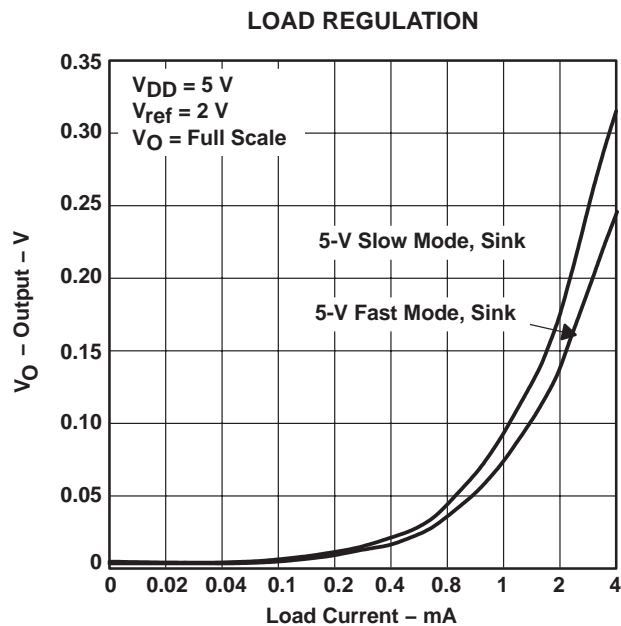
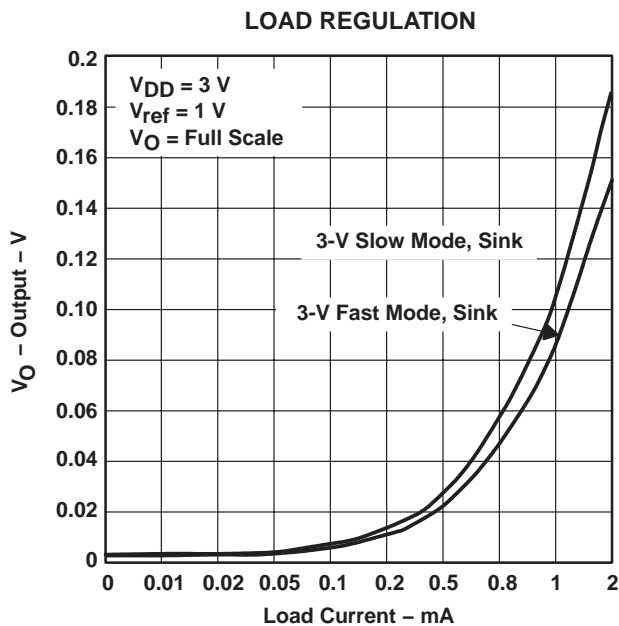

Figure 2. Timing Diagram

TYPICAL CHARACTERISTICS



TLV5614-EP
2.7-V TO 5.5-V 12-BIT 3- μ s QUADRUPLE DIGITAL-TO-ANALOG CONVERTER
WITH POWER DOWN

SGLS355 – JUNE 2006

TYPICAL CHARACTERISTICS

**SUPPLY CURRENT
 vs
 TEMPERATURE**

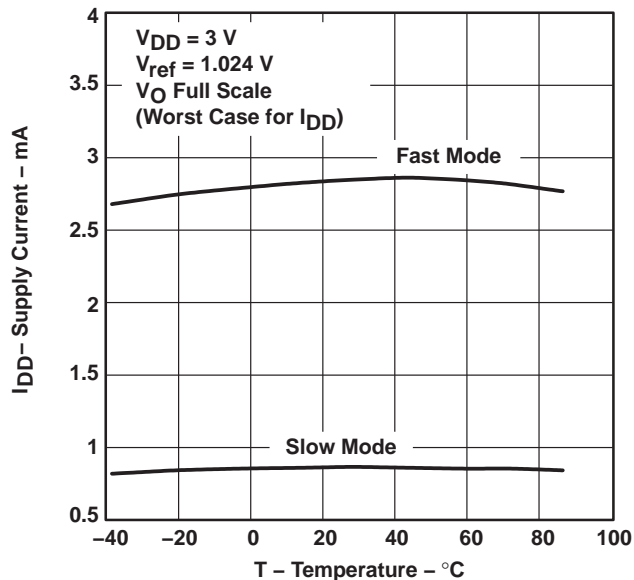

Figure 7

**SUPPLY CURRENT
 vs
 TEMPERATURE**

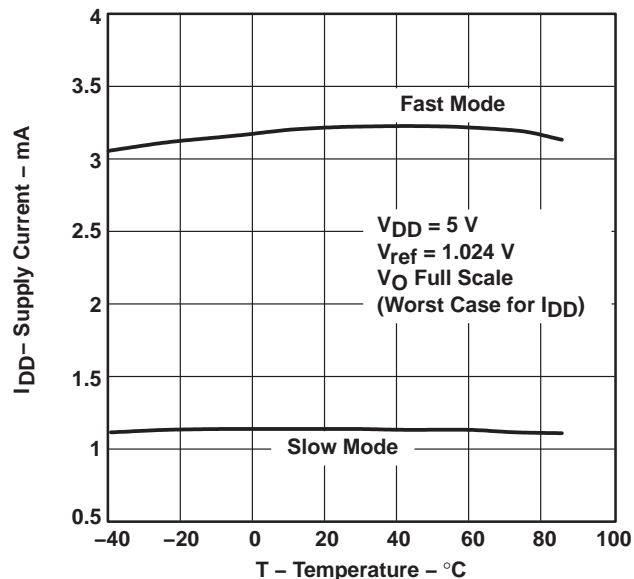

Figure 8

**TOTAL HARMONIC DISTORTION
 vs
 FREQUENCY**

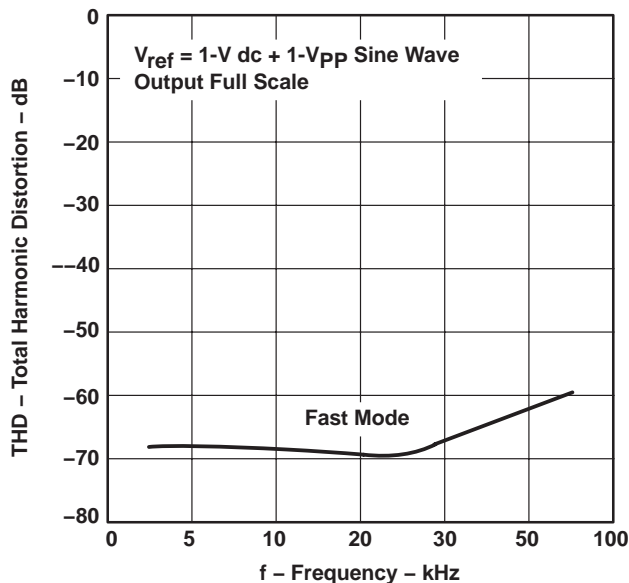

Figure 9

**TOTAL HARMONIC DISTORTION
 vs
 FREQUENCY**

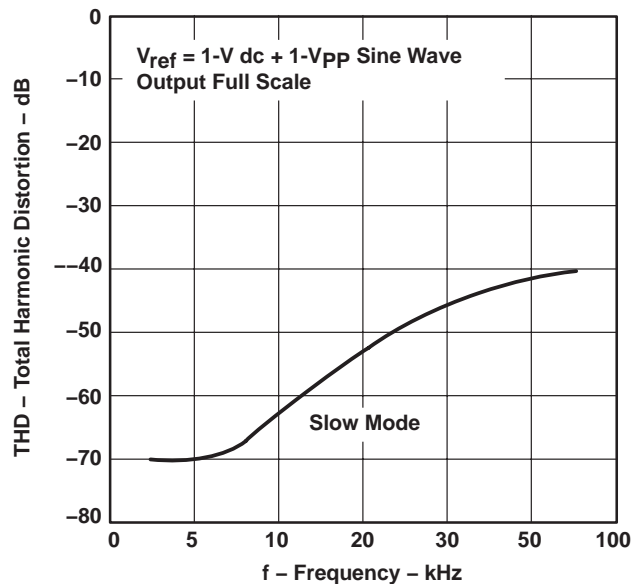

Figure 10



TYPICAL CHARACTERISTICS

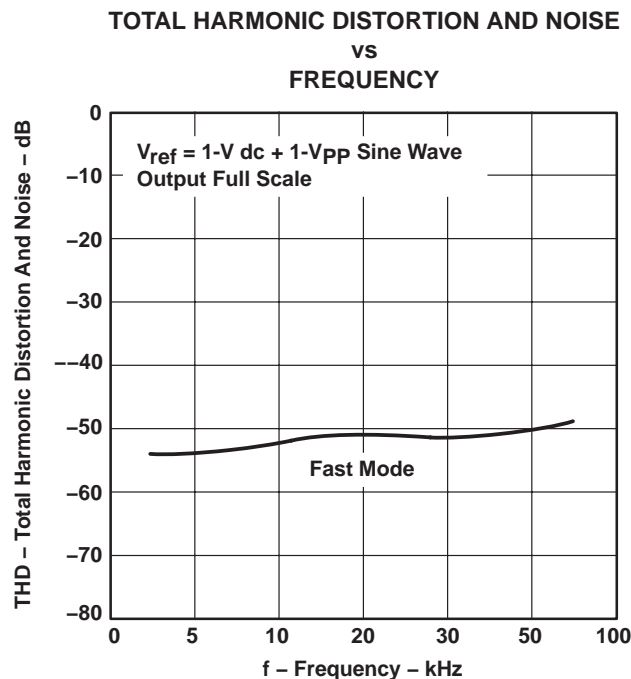

Figure 11

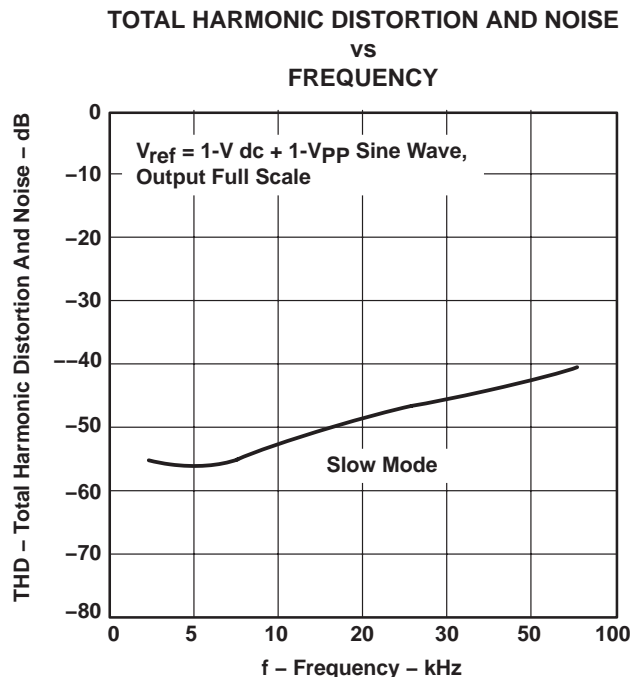

Figure 12

**SUPPLY CURRENT
vs
TIME
(WHEN ENTERING POWER-DOWN MODE)**

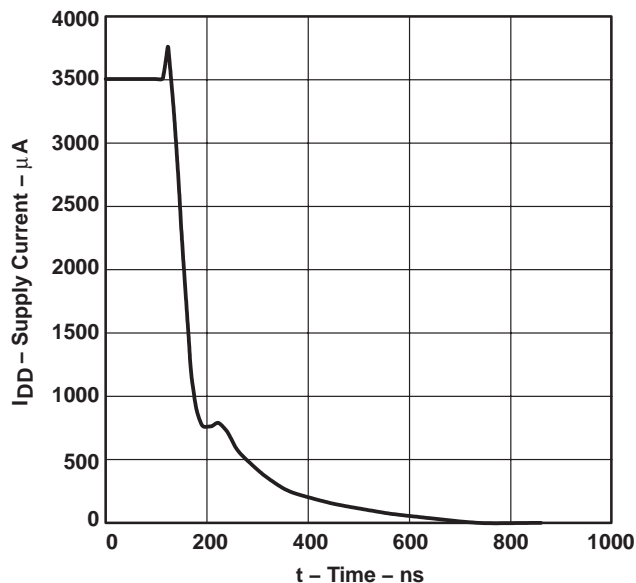

Figure 13

TLV5614-EP
2.7-V TO 5.5-V 12-BIT 3- μ s QUADRUPLE DIGITAL-TO-ANALOG CONVERTER
WITH POWER DOWN

SGLS355 – JUNE 2006

TYPICAL CHARACTERISTICS

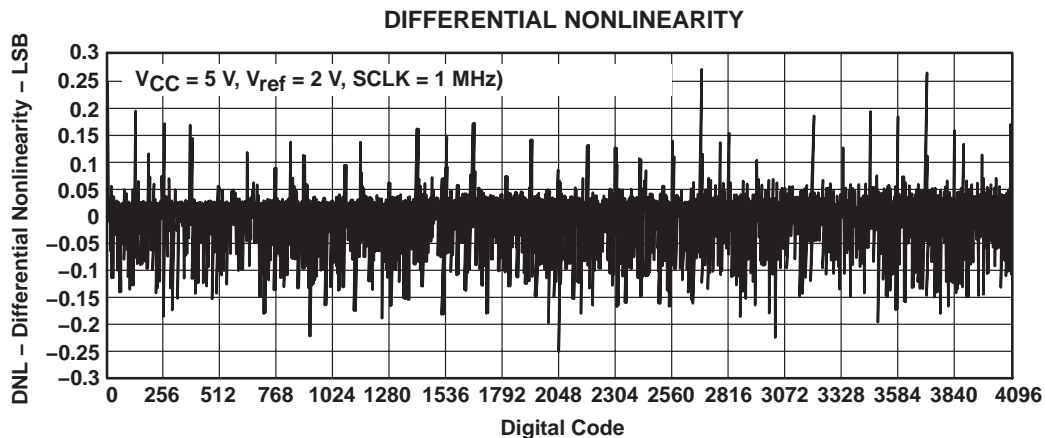

Figure 14

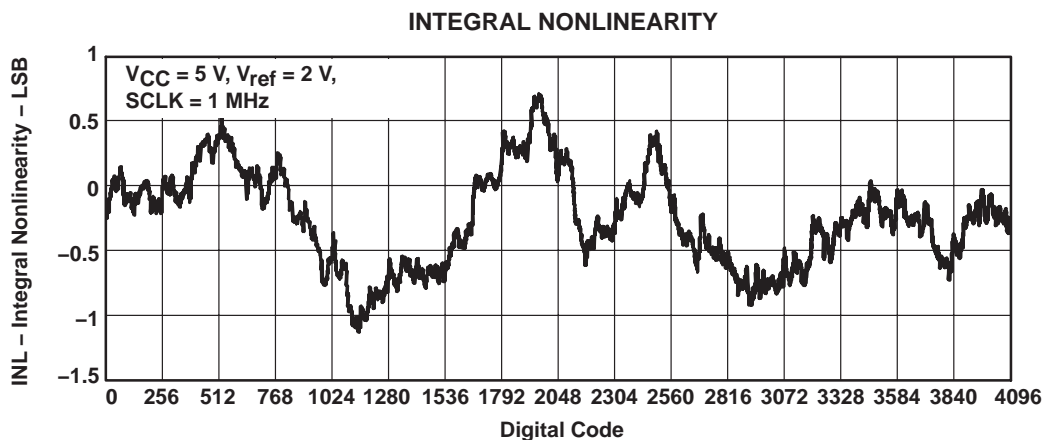

Figure 15

APPLICATION INFORMATION

general function

The TLV5614 is a 12-bit single-supply DAC based on a resistor string architecture. The device consists of a serial interface, speed and power-down control logic, a reference input buffer, a resistor string, and a rail-to-rail output buffer.

The output voltage (full scale determined by external reference) is given by:

$$2 \text{ REF} \frac{\text{CODE}}{2^n} \text{ [V]}$$

where REF is the reference voltage and CODE is the digital input value within the range of 0_{10} to 2^n-1 , where $n = 12$ (bits). The 16-bit data word, consisting of control bits and the new DAC value, is illustrated in the *data format* section. A power-on reset initially resets the internal latches to a defined state (all bits zero).

serial interface

Explanation of data transfer: First, the device has to be enabled with $\overline{\text{CS}}$ set to low. Then, a falling edge of FS starts shifting the data bit per bit (starting with the MSB) to the internal register on the falling edges of SCLK. After 16 bits have been transferred or FS rises, the content of the shift register is moved to the DAC latch, which updates the voltage output to the new level.

The serial interface of the TLV5614 can be used in two basic modes:

- Four wire (with chip select)
- Three wire (without chip select)

Using chip select (four-wire mode), it is possible to have more than one device connected to the serial port of the data source (DSP or microcontroller). The interface is compatible with the TMS320 DSP family. Figure 16 shows an example with two TLV5614s connected directly to a TMS320 DSP.

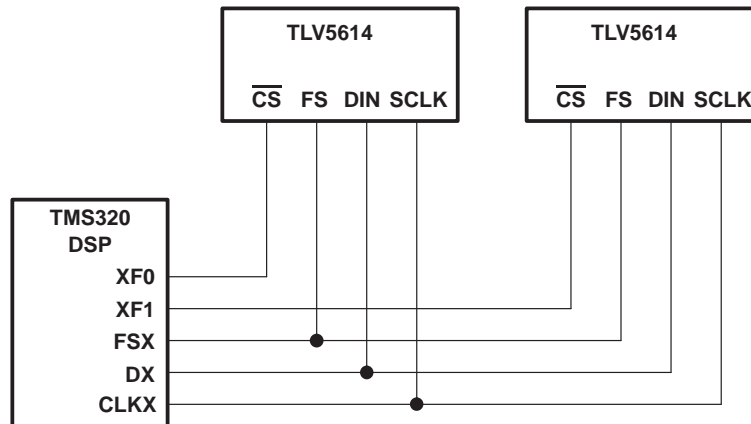

Figure 16. TMS320™ Interface

TLV5614-EP

2.7-V TO 5.5-V 12-BIT 3- μ s QUADRUPLE DIGITAL-TO-ANALOG CONVERTER WITH POWER DOWN

SGLS355 – JUNE 2006

APPLICATION INFORMATION

serial interface (continued)

If there is no need to have more than one device on the serial bus, then \overline{CS} can be tied low. Figure 17 shows an example of how to connect the TLV5614 to a TMS320, SPI, or Microwire port using only three pins.

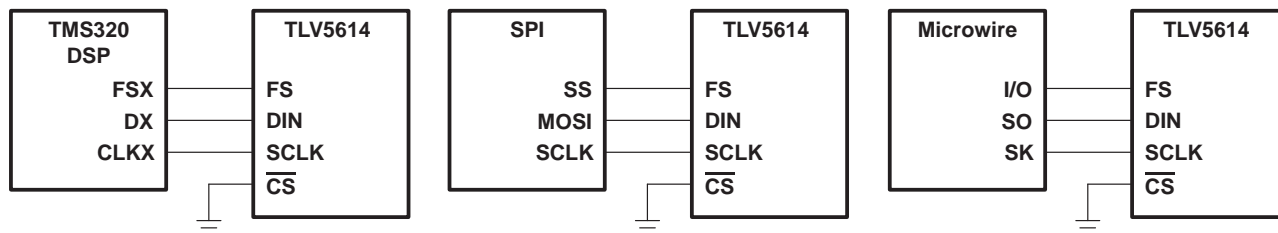

Figure 17. Three-Wire Interface

Notes on SPI and Microwire: Before the controller starts the data transfer, the software has to generate a falling edge on the I/O pin connected to FS. If the word width is 8 bits (SPI and Microwire), two write operations must be performed to program the TLV5614. After the write operation(s), the DAC output is updated automatically on the next positive clock edge, following the sixteenth falling clock edge.

serial clock frequency and update rate

The maximum serial clock frequency is given by:

$$f_{SCLKmax} = \frac{1}{t_{wH(min)} + t_{wL(min)}} = 20 \text{ MHz}$$

The maximum update rate is:

$$f_{UPDATEmax} = \frac{1}{16(t_{wH(min)} + t_{wL(min)})} = 1.25 \text{ MHz}$$

Note that the maximum update rate is a theoretical value for the serial interface, since the settling time of the TLV5614 has to be considered also.

data format

The 16-bit data word for the TLV5614 consists of two parts:

- Control bits (D15 . . . D12)
- New DAC value (D11 . . . D0)

D15	D14	D13	D12	D11	D10	D9	D8	D7	D6	D5	D4	D3	D2	D1	D0
A1	A0	PWR	SPD	New DAC value (12 bits)											

X: Don't care

SPD: Speed control bit: 1 → fast mode 0 → slow mode

PWR: Power control bit: 1 → power down 0 → normal operation

APPLICATION INFORMATION

data format (continued)

In power-down mode, all amplifiers within the TLV5614 are disabled. A particular DAC (A, B, C, D) of the TLV5614 is selected by A1 and A0 within the input word.

A1	A0	DAC
0	0	A
0	1	B
1	0	C
1	1	D

TLV5614 interfaced to TMS320C203 DSP

hardware interfacing

Figure 18 shows an example of how to connect the TLV5614 to a TMS320C203 DSP. The serial port is configured in burst mode, with FSX generated by the TMS320C203 to provide the frame synchronization (FS) input to the TLV5614. Data is transmitted on the DX line, with the serial clock input on the CLKX line. The general-purpose input/output port bits, IO0 and IO1, are used to generate the chip select (\overline{CS}) and DAC latch update (\overline{LDAC}) inputs to the TLV5614. The active-low power down (\overline{PD}) is pulled high all the time to ensure the DACs are enabled.

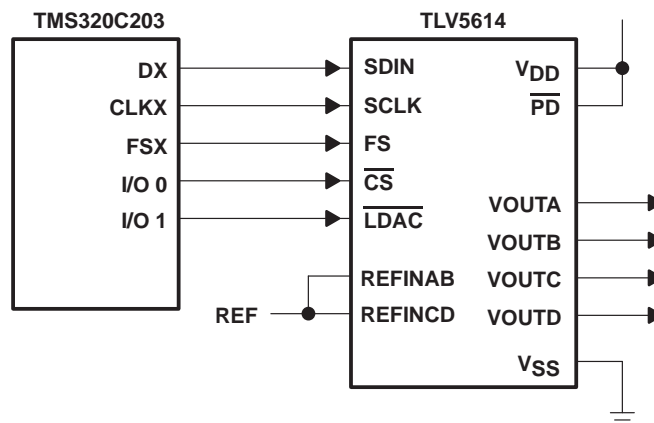

Figure 18. TLV5614 Interfaced With TMS320C203

software

The application example outputs a differential in-phase (sine) signal between the VOUTA and VOUTB pins, and its quadrature (cosine) signal as the differential signal between VOUTC and VOUTD.

The on-chip timer is used to generate interrupts at a fixed frequency. The related interrupt service routine pulses \overline{LDAC} low to update all four DACs simultaneously, then fetches and writes the next sample to all four DACs. The samples are stored in a look-up table, which describes two full periods of a sine wave.

The synchronous serial port of the DSP is used in burst mode. In this mode, the processor generates an FS pulse preceding the MSB of every data word. If multiple, contiguous words are transmitted, a violation of the $t_{su}(C16-FS)$ timing requirement occurs. To avoid this, the program waits until the transmission of the previous word has been completed.

TLV5614-EP

2.7-V TO 5.5-V 12-BIT 3- μ s QUADRUPLE DIGITAL-TO-ANALOG CONVERTER WITH POWER DOWN

SGLS355 - JUNE 2006

APPLICATION INFORMATION

```
-----
; Processor:  TMS320C203 running at 40 MHz
;
; Description:
;
; This program generates a differential in-phase (sine) on (OUTA-OUTB) and it's
; quadrature (cosine) as a differential signal on (OUTC-OUTD).
;
; The DAC codes for the signal samples are stored as a table of 64 12-bit values,
; describing 2 periods of a sine function. A rolling pointer is used to address the
; table location in the first period of this waveform, from which the DAC A samples
; are read. The samples for the other 3 DACs are read at an offset to this rolling
; pointer:
; DAC      Function      Offset from rolling pointer
; A        sine          0
; B        inverse sine  16
; C        cosine        8
; D        inverse cosine24
;
; The on-chip timer is used to generate interrupts at a fixed rate. The interrupt
; service routine first pulses LDAC low to update all DACs simultaneously
; with the values which were written to them in the previous interrupt. Then all
; 4 DAC values are fetched and written out through the synchronous serial interface
; Finally, the rolling pointer is incremented to address the next sample, ready for
; the next interrupt.
;
; © 1998, Texas Instruments Inc.
-----
;----- I/O and memory mapped regs -----
;-----
      .include "regs.asm"
;-----jump vectors -----
      .ps      0h
      b       start
      b       int1
      b       int23
      b       timer_isr;
;----- variables -----
temp      .equ  0060h
r_ptr     .equ  0061h
iosr_stat .equ  0062h
DACA_ptr  .equ  0063h
DACb_ptr  .equ  0064h
DACc_ptr  .equ  0065h
DACd_ptr  .equ  0066h
;-----constants-----
; DAC control bits to be OR'ed onto data
; all fast mode
DACA_control .equ  01000h
DACb_control .equ  05000h
DACc_control .equ  09000h
DACd_control .equ  0d000h
;----- tables -----
      .ds      02000h
sinevals
      .word  00800h
      .word  0097Ch
      .word  00AE9h
      .word  00C3Ah
      .word  00D61h
      .word  00E53h
      .word  00F07h
      .word  00F76h
      .word  00F9Ch
      .word  00F76h
      .word  00F07h
      .word  00E53h
```



APPLICATION INFORMATION

.word 00D61h
.word 00C3Ah
.word 00AE9h
.word 0097Ch
.word 00800h
.word 00684h
.word 00517h
.word 003C6h
.word 0029Fh
.word 001ADh
.word 000F9h
.word 0008Ah
.word 00064h
.word 0008Ah
.word 000F9h
.word 001ADh
.word 0029Fh
.word 003C6h
.word 00517h
.word 00684h
.word 00800h
.word 0097Ch
.word 00AE9h
.word 00C3Ah
.word 00D61h
.word 00E53h
.word 00F07h
.word 00F76h
.word 00F9Ch
.word 00F76h
.word 00F07h
.word 00E53h
.word 00D61h
.word 00C3Ah
.word 00AE9h
.word 0097Ch
.word 00800h
.word 00684h
.word 00517h
.word 003C6h
.word 0029Fh
.word 001ADh
.word 000F9h
.word 0008Ah
.word 00064h
.word 0008Ah
.word 000F9h
.word 001ADh
.word 0029Fh
.word 003C6h
.word 00517h
.word 00684h

APPLICATION INFORMATION

```

;-----
; Main Program
;-----
        .ps    1000h
        .entry
start
;-----
; disable interrupts
;-----
        setc   INTM        ; disable maskable interrupts
        splk   #0ffffh, IFR; clear all interrupts
        splk   #0004h, IMR; timer interrupts unmasked
;-----
; set up the timer
; timer period set by values in PRD and TDDR
; period = (CLKOUT1 period) x (1+PRD) x (1+TDDR)
; examples for TMS320C203 with 40MHz main clock
; Timer rate      TDDR  PRD
; 80 kHz          9     24 (18h)
; 50 kHz          9     39 (27h)
;-----
prd_val.equ      0018h
tcr_val.equ      0029h
        splk   #0000h, temp; clear timer
        out   temp, TIM
        splk   #prd_val, temp; set PRD
        out   temp, PRD
        splk   #tcr_val, temp; set TDDR, and TRB=1 for auto-reload
        out   temp, TCR
;-----
; Configure IO0/1 as outputs to be :
; IO0 CS - and set high
; IO1 LDAC - and set high
;-----
        in    temp, ASPCR; configure as output
        lacl  temp
        or    #0003h
        sacl  temp
        out   temp, ASPCR
        in    temp, IOSR; set them high
        lacl  temp
        or    #0003h
        sacl  temp
        out   temp, IOSR
;-----
; set up serial port for
; SSPCR.TXM=1    Transmit mode - generate FSX
; SSPCR.MCM=1    Clock mode - internal clock source
; SSPCR.FSM=1    Burst mode
;-----
        splk   #0000Eh, temp
        out   temp, SSPCR; reset transmitter
        splk   #0002Eh, temp
        out   temp, SSPCR
;-----
; reset the rolling pointer
;-----
        lacl  #000h
        sacl  r_ptr
;-----
; enable interrupts
;-----
        clrc  INTM        ; enable maskable interrupts
;-----
; loop forever!
;-----

```

APPLICATION INFORMATION

```

next  idle          ;wait for interrupt
      b            next
;-----
; all else fails stop here
;-----
done  b            done          ;hang there
;-----
; Interrupt Service Routines
;-----
int1  ret          ; do nothing and return
int23 ret         ; do nothing and return
timer_isr:
  in   iosr_stat, IOSR; store IOSR value into variable space
  lacl iosr_stat   ; load acc with iosr status
  and  #0FFFDh    ; reset IO1 - LDAC low
  sacl temp       ;
  out  temp, IOSR ;
  or   #0002h    ; set IO1 - LDAC high
  sacl temp       ;
  out  temp, IOSR ;
  and  #0FFFEh   ; reset IO0 - CS low
  sacl temp       ;
  out  temp, IOSR ;
  lacl r_ptr     ; load rolling pointer to accumulator
  add  #sinevals ; add pointer to table start
  sacl DACa_ptr  ; to get a pointer for next DAC a sample
  add  #08h      ; add 8 to get to DAC C pointer
  sacl DACc_ptr  ;
  add  #08h      ; add 8 to get to DAC B pointer
  sacl DACb_ptr  ;
  add  #08h      ; add 8 to get to DAC D pointer
  sacl DACd_ptr  ;
  mar  *,ar0     ; set ar0 as current AR

; DAC A
  lar  ar0, DACa_ptr; ar0 points to DAC a sample
  lacl *          ; get DAC a sample into accumulator
  or   #DACa_control; OR in DAC A control bits
  sacl temp       ;
  out  temp, SDTR ; send data
;-----
; We must wait for transmission to complete before writing next word to the SDTR.;
TLV5614/04 interface does not allow the use of burst mode with the full packet; rate, as
we need a CLKX -ve edge to clock in last bit before FS goes high again;; to allow SPI
compatibility.
;-----
  rpt  #016h      ; wait long enough for this configuration
  nop                    ; of MCLK/CLKOUT1 rate

; DAC B
  lar  ar0, dacb_ptr; ar0 points to DAC a sample
  lacl *          ; get DAC a sample into accumulator
  or   #DACb_control; OR in DAC B control bits
  sacl temp       ;
  out  temp, SDTR ; send data
  rpt  #016h      ; wait long enough for this configuration
  nop                    ; of MCLK/CLKOUT1 rate

; DAC C
  lar  ar0, dacc_ptr; ar0 points to dac a sample
  lacl *          ; get DAC a sample into accumulator
  or   #DACc_control; OR in DAC C control bits
  sacl temp       ;
  out  temp, SDTR; send data
  rpt  #016h      ; wait long enough for this configuration
  nop                    ; of MCLK/CLKOUT1 rate

```

TLV5614-EP

2.7-V TO 5.5-V 12-BIT 3- μ s QUADRUPLE DIGITAL-TO-ANALOG CONVERTER WITH POWER DOWN

SGLS355 - JUNE 2006

APPLICATION INFORMATION

```
; DAC D
  lar      ar0, dacd_ptr; ar0 points to DAC a sample
  lacl    *          ; get DAC a sample into accumulator
  or      #dacd_control; OR in DAC D control bits
  sac1    temp      ;
  out     temp, SDTR ; send data

  lacl    r_ptr     ; load rolling pointer to accumulator
  add     #1h       ; increment rolling pointer
  and     #001Fh    ; count 0-31 then wrap back round
  sac1    r_ptr     ; store rolling pointer
  rpt     #016h     ; wait long enough for this configuration
  nop

; now take CS high again
  lacl    iosr_stat ; load acc with iosr status
  or      #0001h    ; set IO0 - CS high
  sac1    temp      ;
  out     temp, IOSR ;
  clrc    intm      ; re-enable interrupts
  ret

.end
```



APPLICATION INFORMATION

TLV5614 interfaced to MCS[®]51 microcontroller

hardware interfacing

Figure 19 shows an example of how to connect the TLV5614 to an MCS[®]51 Microcontroller. The serial DAC input data and external control signals are sent via I/O port 3 of the controller. The serial data is sent on the RxD line, with the serial clock output on the TxD line. Port 3 bits 3, 4, and 5 are configured as outputs to provide the DAC latch update ($\overline{\text{LDAC}}$), chip select ($\overline{\text{CS}}$) and frame sync (FS) signals for the TLV5614. The active low power down pin ($\overline{\text{PD}}$) of the TLV5614 is pulled high to ensure that the DACs are enabled.

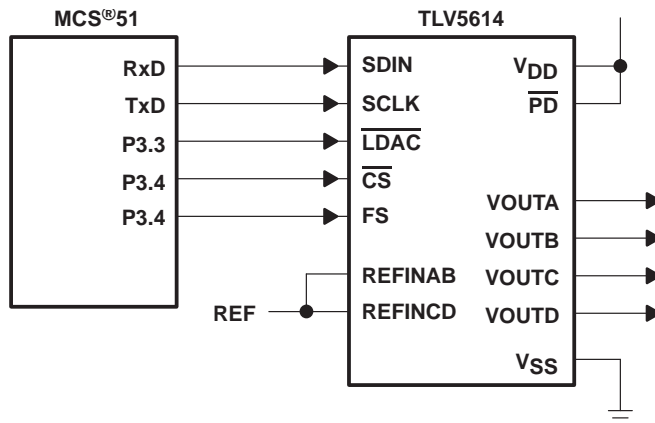

Figure 19. TLV5614 Interfaced With MCS[®]51

software

The example is the same as for the TMS320C203 in this data sheet, but adapted for a MCS[®]51 controller. It generates a differential in-phase (sine) signal between the VOUTA and VOUTB pins, and its quadrature (cosine) signal is the differential signal between VOUTC and VOUTD.

The on-chip timer is used to generate interrupts at a fixed frequency. The related interrupt service routine pulses $\overline{\text{LDAC}}$ low to update all four DACs simultaneously, then fetches and writes the next sample to all four DACs. The samples are stored as a look-up table, which describes one full period of a sine wave.

The serial port of the controller is used in Mode 0, which transmits 8 bits of data on RxD, accompanied by a synchronous clock on TxD. Two writes, concatenated together, are required to write a complete word to the TLV5614. The $\overline{\text{CS}}$ and FS signals are provided in the required fashion through control of IO port 3, which has bit addressable outputs.

TLV5614-EP
2.7-V TO 5.5-V 12-BIT 3- μ s QUADRUPLE DIGITAL-TO-ANALOG CONVERTER
WITH POWER DOWN

SGLS355 – JUNE 2006

APPLICATION INFORMATION

```

;-----
; Processor: 80C51
;
; Description:
;
; This program generates a differential in-phase
(sine) on (OUTA-OUTB) ; and it's quadrature (cosine)
as a differential signal on (OUTC-OUTD).
;
; © 1998, Texas Instruments Inc.
;-----
NAME GENIQ
MAIN SEGMENT CODE
ISR SEGMENT CODE
SINTBL SEGMENT CODE
VAR1 SEGMENT DATA
STACK SEGMENT IDATA
;-----
; Code start at address 0, jump to start
;-----
CSEG AT 0
LJMP start ; Execution starts at address 0 on power-up.
;-----
; Code in the timer0 interrupt vector
;-----
CSEG AT 0BH
LJMP timer0isr ; Jump vector for timer 0 interrupt is 000Bh
;-----
; Global variables need space allocated
;-----
RSEG VAR1
temp_ptr: DS 1
rolling_ptr: DS 1
;-----
; Interrupt service routine for timer 0 interrupts
;-----
RSEG ISR
timer0isr:
PUSH PSW
PUSH ACC
CLR INT1 ; pulse LDAC low
SETB INT1 ; to latch all 4 previous values at the same time
; 1st thing done in timer isr => fixed period
CLR T0 ; set CS low

; The signal to be output on each DAC is a sine function.
; One cycle of a sine wave is held in a table @ sinevals
; as 32 samples of msb, lsb pairs (64 bytes).
; We have ; one pointer which rolls round this table, rolling_ptr,
; incrementing by 2 bytes (1 sample) on each interrupt (at the end of
; this routine).

; The DAC samples are read at an offset to this rolling pointer:
; DAC Function Offset from rolling_ptr
; A sine 0
; B inverse sine 32
; C cosine 16
; D inverse cosine48
MOV DPTR,#sinevals; set DPTR to the start of the table
; of sine signal values
MOV R7,rolling_ptr; R7 holds the pointer
; into the sine table

MOV A,R7 ; get DAC A msb
MOVC A,@A+DPTR ; msb of DAC A is in the ACC

```



APPLICATION INFORMATION

```

CLR    T1            ; transmit it - set FS low
MOV    SBUF,A        ; send it out the serial port

INC    R7            ; increment the pointer in R7
MOV    A,R7          ; to get the next byte from the table
MOVC   A,@A+DPTR    ; which is the lsb of this sample, now in ACC
A_MSB_TX:
JNB    TI,A_MSB_TX  ; wait for transmit to complete
CLR    TI            ; clear for new transmit
MOV    SBUF,A        ; and send out the lsb of DAC A

; DAC C next
; DAC C codes should be taken from 16 bytes (8 samples) further on
; in the sine table - this gives a cosine function
MOV    A,R7          ; pointer in R7
ADD    A,#0FH        ; add 15 - already done one INC
ANL    A,#03FH       ; wrap back round to 0 if > 64
MOV    R7,A          ; pointer back in R7

MOVC   A,@A+DPTR    ; get DAC C msb from the table
ORL    A,#01H        ; set control bits to DAC C address
A_LSB_TX:
JNB    TI,A_LSB_TX  ; wait for DAC A lsb transmit to complete
SETB   T1            ; toggle FS
CLR    T1
CLR    TI            ; clear for new transmit
MOV    SBUF,A        ; and send out the msb of DAC C
INC    R7            ; increment the pointer in R7
MOV    A,R7          ; to get the next byte from the table
MOVC   A,@A+DPTR    ; which is the lsb of this sample, now in ACC
C_MSB_TX:
JNB    TI,C_MSB_TX  ; wait for transmit to complete
CLR    TI            ; clear for new transmit
MOV    SBUF,A        ; and send out the lsb of DAC C

; DAC B next
; DAC B codes should be taken from 16 bytes (8 samples) further on
; in the sine table - this gives an inverted sine function
MOV    A,R7          ; pointer in R7
ADD    A,#0FH        ; add 15 - already done one INC
ANL    A,#03FH       ; wrap back round to 0 if > 64
MOV    R7,A          ; pointer back in R7

MOVC   A,@A+DPTR    ; get DAC B msb from the table
ORL    A,#02H        ; set control bits to DAC B address
C_LSB_TX:
JNB    TI,C_LSB_TX  ; wait for DAC C lsb transmit to complete
SETB   T1            ; toggle FS
CLR    T1
CLR    TI            ; clear for new transmit
MOV    SBUF,A        ; and send out the msb of DAC B

; get DAC B LSB
INC    R7            ; increment the pointer in R7
MOV    A,R7          ; to get the next byte from the table
MOVC   A,@A+DPTR    ; which is the lsb of this sample, now in ACC
B_MSB_TX:
JNB    TI,B_MSB_TX  ; wait for transmit to complete
CLR    TI            ; clear for new transmit
MOV    SBUF,A        ; and send out the lsb of DAC B

; DAC D next
; DAC D codes should be taken from 16 bytes (8 samples) further on
; in the sine table - this gives an inverted cosine function

```

APPLICATION INFORMATION

```

MOV    A,R7          ; pointer in R7
ADD    A,#0FH        ; add 15 - already done one INC
ANL    A,#03FH       ; wrap back round to 0 if > 64
MOV    R7,A          ; pointer back in R7
MOVC   A,@A+DPTR     ; get DAC D msb from the table
ORL    A,#03H        ; set control bits to DAC D address

B_LSB_TX:
JNB    TI,B_LSB_TX   ; wait for DAC B lsb transmit to complete
SETB   T1            ; toggle FS
CLR    T1
CLR    TI ; clear for new transmit
MOV    SBUF,A        ; and send out the msb of DAC D

    INC    R7          ; increment the pointer in R7
    MOV    A,R7        ; to get the next byte from the table
    MOVC   A,@A+DPTR   ; which is the lsb of this sample, now in ACC
D_MSB_TX:
JNB    TI,D_MSB_TX   ; wait for transmit to complete
CLR    TI            ; clear for new transmit
MOV    SBUF,A        ; and send out the lsb of DAC D

    ; increment the rolling pointer to point to the next sample
    ; ready for the next interrupt
    MOV    A,rolling_ptr
    ADD    A,#02H      ; add 2 to the rolling pointer
    ANL    A,#03FH     ; wrap back round to 0 if > 64
    MOV    rolling_ptr,A ; store in memory again
D_LSB_TX:
JNB    TI,D_LSB_TX   ; wait for DAC D lsb transmit to complete
CLR    TI            ; clear for next transmit
SETB   T1            ; FS high
SETB   T0            ; CS high
POP    ACC
POP    PSW
RETI

;-----
; Stack needs definition
;-----
RSEG   STACK
DS     10h           ; 16 Byte Stack!
;-----
; Main program code
;-----
RSEG   MAIN
start:
MOV    SP,#STACK-1  ; first set Stack Pointer
CLRA
MOV    SCON,A       ; set serial port 0 to mode 0
MOV    TMOD,#02H    ; set timer 0 to mode 2 - auto-reload
MOV    TH0,#038H    ; set TH0 for 5kHs interrupts
SETB   INT1         ; set LDAC = 1
SETB   T1           ; set FS = 1
SETB   T0           ; set CS = 1
SETB   ET0         ; enable timer 0 interrupts
SETB   EA          ; enable all interrupts
MOV    rolling_ptr,A ; set rolling pointer to 0
SETB   TR0         ; start timer 0
always:
SJMP   always      ; while(1) !
RET

;-----
; Table of 32 sine wave samples used as DAC data
;-----
RSEG   SINTBL

```

APPLICATION INFORMATION

sinevals:

```
DW 01000H
DW 0903EH
DW 05097H
DW 0305CH
DW 0B086H
DW 070CAH
DW 0F0E0H
DW 0F06EH
DW 0F039H
DW 0F06EH
DW 0F0E0H
DW 070CAH
DW 0B086H
DW 0305CH
DW 05097H
DW 0903EH
DW 01000H
DW 06021H
DW 0A0E8H
DW 0C063H
DW 040F9H
DW 080B5H
DW 0009FH
DW 00051H
DW 00026H
DW 00051H
DW 0009FH
DW 080B5H
DW 040F9H
DW 0C063H
DW 0A0E8H
DW 06021H
```

END

PACKAGING INFORMATION

Orderable Device	Status (1)	Package Type	Package Drawing	Pins	Package Qty	Eco Plan (2)	Lead/Ball Finish	MSL Peak Temp (3)	Op Temp (°C)	Top-Side Markings (4)	Samples
TLV5614MPWREP	ACTIVE	TSSOP	PW	16	2000	Green (RoHS & no Sb/Br)	CU NIPDAU	Level-1-260C-UNLIM	-55 to 125	5614EP	Samples
V62/06602-01XE	ACTIVE	TSSOP	PW	16	2000	Green (RoHS & no Sb/Br)	CU NIPDAU	Level-1-260C-UNLIM	-55 to 125	5614EP	Samples

(1) The marketing status values are defined as follows:

ACTIVE: Product device recommended for new designs.

LIFEBUY: TI has announced that the device will be discontinued, and a lifetime-buy period is in effect.

NRND: Not recommended for new designs. Device is in production to support existing customers, but TI does not recommend using this part in a new design.

PREVIEW: Device has been announced but is not in production. Samples may or may not be available.

OBSOLETE: TI has discontinued the production of the device.

(2) Eco Plan - The planned eco-friendly classification: Pb-Free (RoHS), Pb-Free (RoHS Exempt), or Green (RoHS & no Sb/Br) - please check <http://www.ti.com/productcontent> for the latest availability information and additional product content details.

TBD: The Pb-Free/Green conversion plan has not been defined.

Pb-Free (RoHS): TI's terms "Lead-Free" or "Pb-Free" mean semiconductor products that are compatible with the current RoHS requirements for all 6 substances, including the requirement that lead not exceed 0.1% by weight in homogeneous materials. Where designed to be soldered at high temperatures, TI Pb-Free products are suitable for use in specified lead-free processes.

Pb-Free (RoHS Exempt): This component has a RoHS exemption for either 1) lead-based flip-chip solder bumps used between the die and package, or 2) lead-based die adhesive used between the die and leadframe. The component is otherwise considered Pb-Free (RoHS compatible) as defined above.

Green (RoHS & no Sb/Br): TI defines "Green" to mean Pb-Free (RoHS compatible), and free of Bromine (Br) and Antimony (Sb) based flame retardants (Br or Sb do not exceed 0.1% by weight in homogeneous material)

(3) MSL, Peak Temp. -- The Moisture Sensitivity Level rating according to the JEDEC industry standard classifications, and peak solder temperature.

(4) Only one of markings shown within the brackets will appear on the physical device.

Important Information and Disclaimer: The information provided on this page represents TI's knowledge and belief as of the date that it is provided. TI bases its knowledge and belief on information provided by third parties, and makes no representation or warranty as to the accuracy of such information. Efforts are underway to better integrate information from third parties. TI has taken and continues to take reasonable steps to provide representative and accurate information but may not have conducted destructive testing or chemical analysis on incoming materials and chemicals. TI and TI suppliers consider certain information to be proprietary, and thus CAS numbers and other limited information may not be available for release.

In no event shall TI's liability arising out of such information exceed the total purchase price of the TI part(s) at issue in this document sold by TI to Customer on an annual basis.

OTHER QUALIFIED VERSIONS OF TLV5614-EP :

- Catalog: [TLV5614](#)

NOTE: Qualified Version Definitions:

- Catalog - TI's standard catalog product

TAPE AND REEL INFORMATION



QUADRANT ASSIGNMENTS FOR PIN 1 ORIENTATION IN TAPE



*All dimensions are nominal

Device	Package Type	Package Drawing	Pins	SPQ	Reel Diameter (mm)	Reel Width W1 (mm)	A0 (mm)	B0 (mm)	K0 (mm)	P1 (mm)	W (mm)	Pin1 Quadrant
TLV5614MPWREP	TSSOP	PW	16	2000	330.0	12.4	6.9	5.6	1.6	8.0	12.0	Q1

TAPE AND REEL BOX DIMENSIONS



*All dimensions are nominal

Device	Package Type	Package Drawing	Pins	SPQ	Length (mm)	Width (mm)	Height (mm)
TLV5614MPWREP	TSSOP	PW	16	2000	367.0	367.0	35.0

PW (R-PDSO-G14)

PLASTIC SMALL OUTLINE



4040064-3/G 02/11



- NOTES:
- A. All linear dimensions are in millimeters. Dimensioning and tolerancing per ASME Y14.5M-1994.
 - B. This drawing is subject to change without notice.
 - C. Body length does not include mold flash, protrusions, or gate burrs. Mold flash, protrusions, or gate burrs shall not exceed 0,15 each side.
 - D. Body width does not include interlead flash. Interlead flash shall not exceed 0,25 each side.
 - E. Falls within JEDEC MO-153

PW (R-PDSO-G16)

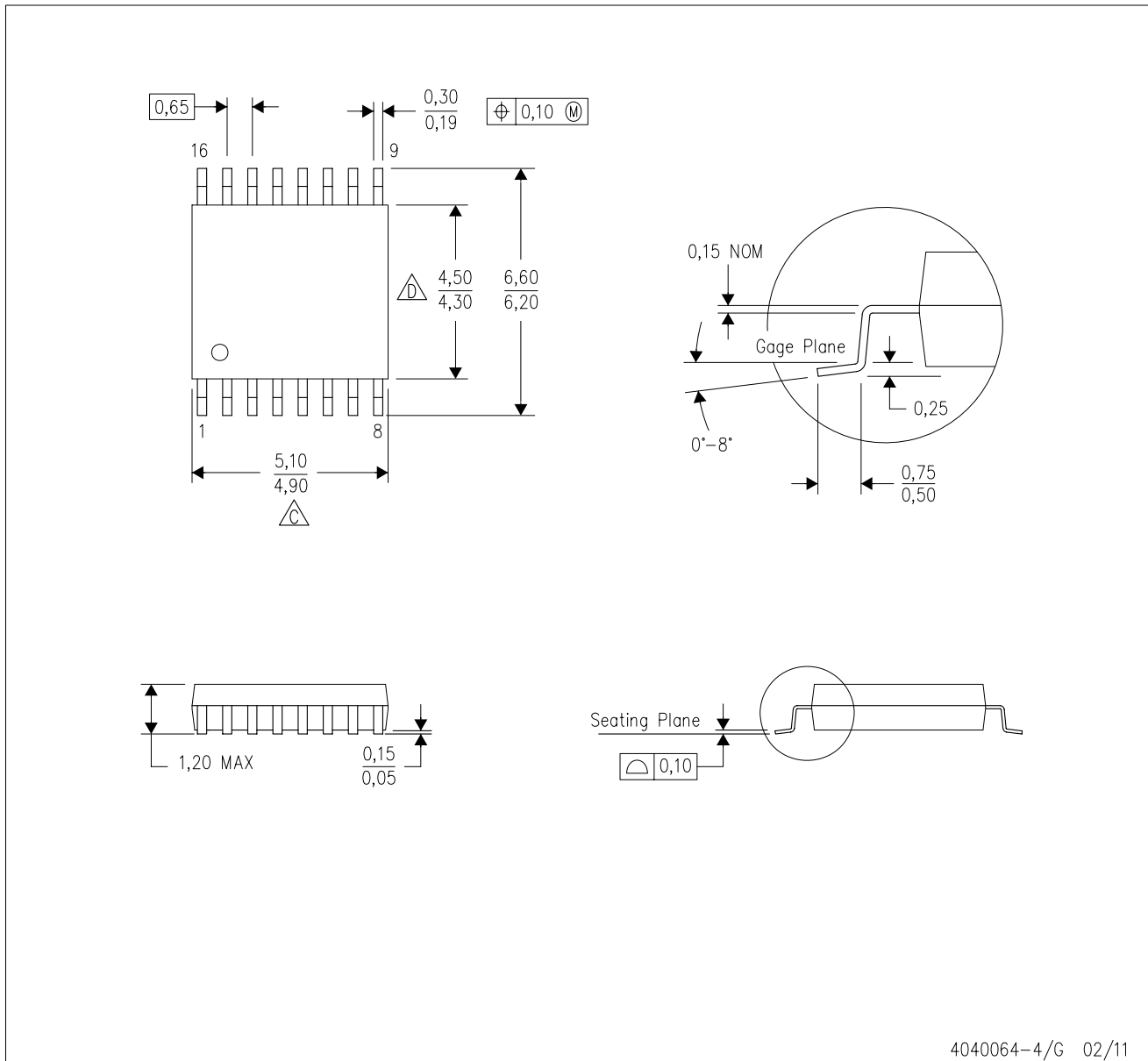
PLASTIC SMALL OUTLINE



4040064-4/G 02/11

- NOTES:
- A. All linear dimensions are in millimeters. Dimensioning and tolerancing per ASME Y14.5M-1994.
 - B. This drawing is subject to change without notice.
 -  Body length does not include mold flash, protrusions, or gate burrs. Mold flash, protrusions, or gate burrs shall not exceed 0,15 each side.
 -  Body width does not include interlead flash. Interlead flash shall not exceed 0,25 each side.
 - E. Falls within JEDEC MO-153

PW (R-PDSO-G16)

PLASTIC SMALL OUTLINE

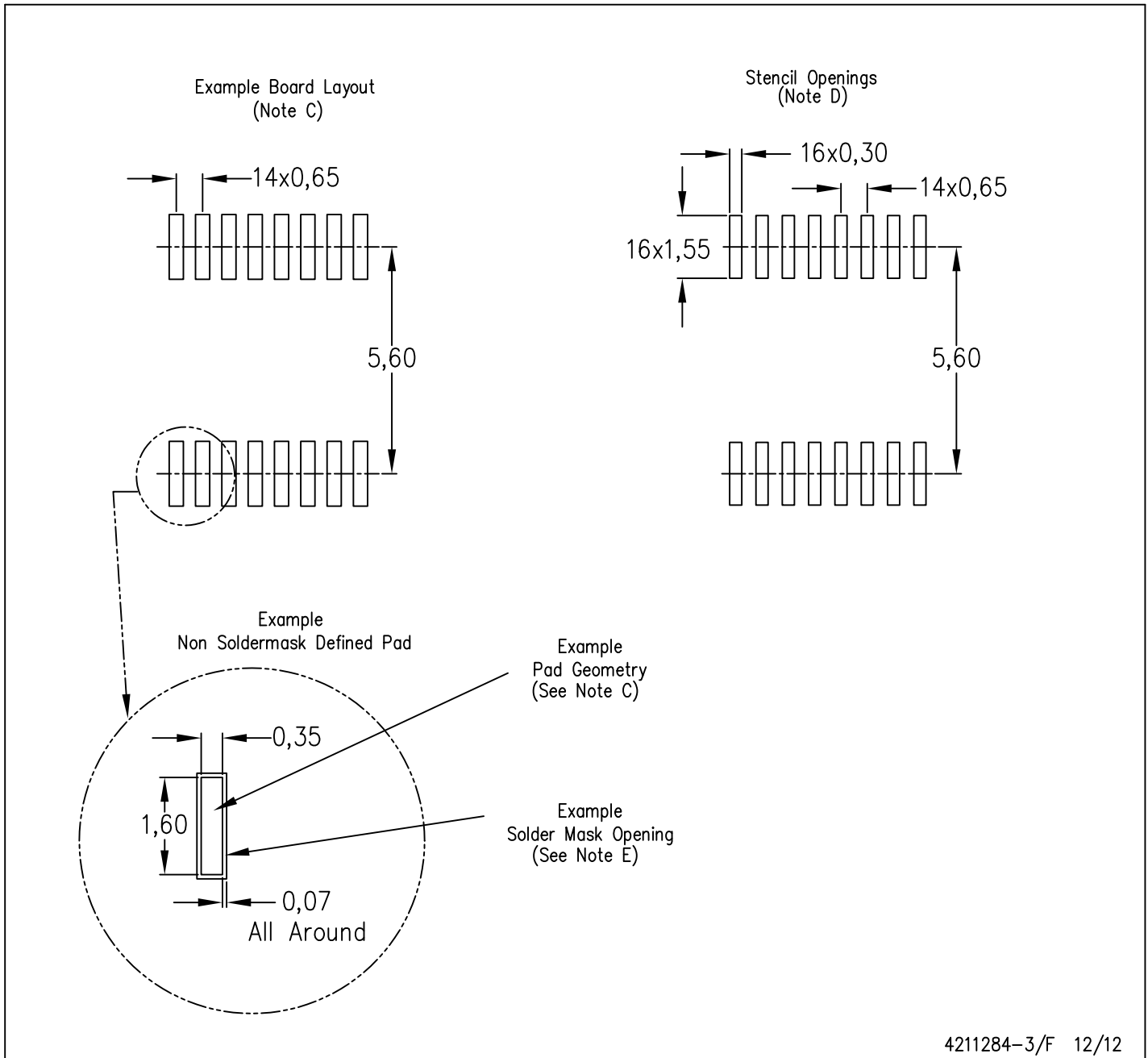

4211284-3/F 12/12

- NOTES:
- A. All linear dimensions are in millimeters.
 - B. This drawing is subject to change without notice.
 - C. Publication IPC-7351 is recommended for alternate designs.
 - D. Laser cutting apertures with trapezoidal walls and also rounding corners will offer better paste release. Customers should contact their board assembly site for stencil design recommendations. Refer to IPC-7525 for other stencil recommendations.
 - E. Customers should contact their board fabrication site for solder mask tolerances between and around signal pads.

IMPORTANT NOTICE

Texas Instruments Incorporated and its subsidiaries (TI) reserve the right to make corrections, enhancements, improvements and other changes to its semiconductor products and services per JESD46, latest issue, and to discontinue any product or service per JESD48, latest issue. Buyers should obtain the latest relevant information before placing orders and should verify that such information is current and complete. All semiconductor products (also referred to herein as "components") are sold subject to TI's terms and conditions of sale supplied at the time of order acknowledgment.

TI warrants performance of its components to the specifications applicable at the time of sale, in accordance with the warranty in TI's terms and conditions of sale of semiconductor products. Testing and other quality control techniques are used to the extent TI deems necessary to support this warranty. Except where mandated by applicable law, testing of all parameters of each component is not necessarily performed.

TI assumes no liability for applications assistance or the design of Buyers' products. Buyers are responsible for their products and applications using TI components. To minimize the risks associated with Buyers' products and applications, Buyers should provide adequate design and operating safeguards.

TI does not warrant or represent that any license, either express or implied, is granted under any patent right, copyright, mask work right, or other intellectual property right relating to any combination, machine, or process in which TI components or services are used. Information published by TI regarding third-party products or services does not constitute a license to use such products or services or a warranty or endorsement thereof. Use of such information may require a license from a third party under the patents or other intellectual property of the third party, or a license from TI under the patents or other intellectual property of TI.

Reproduction of significant portions of TI information in TI data books or data sheets is permissible only if reproduction is without alteration and is accompanied by all associated warranties, conditions, limitations, and notices. TI is not responsible or liable for such altered documentation. Information of third parties may be subject to additional restrictions.

Resale of TI components or services with statements different from or beyond the parameters stated by TI for that component or service voids all express and any implied warranties for the associated TI component or service and is an unfair and deceptive business practice. TI is not responsible or liable for any such statements.

Buyer acknowledges and agrees that it is solely responsible for compliance with all legal, regulatory and safety-related requirements concerning its products, and any use of TI components in its applications, notwithstanding any applications-related information or support that may be provided by TI. Buyer represents and agrees that it has all the necessary expertise to create and implement safeguards which anticipate dangerous consequences of failures, monitor failures and their consequences, lessen the likelihood of failures that might cause harm and take appropriate remedial actions. Buyer will fully indemnify TI and its representatives against any damages arising out of the use of any TI components in safety-critical applications.

In some cases, TI components may be promoted specifically to facilitate safety-related applications. With such components, TI's goal is to help enable customers to design and create their own end-product solutions that meet applicable functional safety standards and requirements. Nonetheless, such components are subject to these terms.

No TI components are authorized for use in FDA Class III (or similar life-critical medical equipment) unless authorized officers of the parties have executed a special agreement specifically governing such use.

Only those TI components which TI has specifically designated as military grade or "enhanced plastic" are designed and intended for use in military/aerospace applications or environments. Buyer acknowledges and agrees that any military or aerospace use of TI components which have **not** been so designated is solely at the Buyer's risk, and that Buyer is solely responsible for compliance with all legal and regulatory requirements in connection with such use.

TI has specifically designated certain components as meeting ISO/TS16949 requirements, mainly for automotive use. In any case of use of non-designated products, TI will not be responsible for any failure to meet ISO/TS16949.

Products

Audio	www.ti.com/audio
Amplifiers	amplifier.ti.com
Data Converters	dataconverter.ti.com
DLP® Products	www.dlp.com
DSP	dsp.ti.com
Clocks and Timers	www.ti.com/clocks
Interface	interface.ti.com
Logic	logic.ti.com
Power Mgmt	power.ti.com
Microcontrollers	microcontroller.ti.com
RFID	www.ti-rfid.com
OMAP Applications Processors	www.ti.com/omap
Wireless Connectivity	www.ti.com/wirelessconnectivity

Applications

Automotive and Transportation	www.ti.com/automotive
Communications and Telecom	www.ti.com/communications
Computers and Peripherals	www.ti.com/computers
Consumer Electronics	www.ti.com/consumer-apps
Energy and Lighting	www.ti.com/energy
Industrial	www.ti.com/industrial
Medical	www.ti.com/medical
Security	www.ti.com/security
Space, Avionics and Defense	www.ti.com/space-avionics-defense
Video and Imaging	www.ti.com/video

TI E2E Community

e2e.ti.com