

SUPPLY VOLTAGE SUPERVISORS

- POWER-ON RESET GENERATOR
- AUTOMATIC RESET GENERATION AFTER VOLTAGE DROP
- WIDE SUPPLY VOLTAGE RANGE ... 3 V TO 18 V
- PRECISION VOLTAGE SENSOR
- TEMPERATURE-COMPENSATED VOLTAGE REFERENCE
- TRUE AND COMPLEMENT RESET OUTPUTS
- EXTERNALLY ADJUSTABLE PULSE WIDTH

DESCRIPTION

The TL7700A series are monolithic integrated circuit supply voltage supervisors specifically designed for use as reset controllers in microcomputer and microprocessor systems. During power-up the device tests the supply voltage and keeps the RESET and $\overline{\text{RESET}}$ outputs active (high and low, respectively) as long as the supply voltage has not reached its nominal voltage value. Taking $\overline{\text{RESIN}}$ low has the same effect. To ensure that the microcomputer system has reset, the TL7700A then initiates an internal time delay that delays the return of the reset outputs to their inactive states. Since the time delay for most microcomputers and microproces-

sors is in the order of several machine cycles, the device internal time delay is determined by an external time delay is determined by an external capacitor connected to the C_T input (pin 3).

$$t_d = 1.3 \times 10^4 \times C_T$$

Where : C_T is in farads (F) and t_d in seconds (s). In addition, when the supply voltage drops below the nominal value, the outputs will be active until the supply voltage returns to the nominal value. An external capacitor (typically 0.1 μF) must be connected to the REF output (pin 1) to reduce the influence of fast transients in the supply voltage.

The TL7700AI series is characterized for operation from -25°C to 85°C ; the TL7700AC series is characterized from 0°C to 70°C .

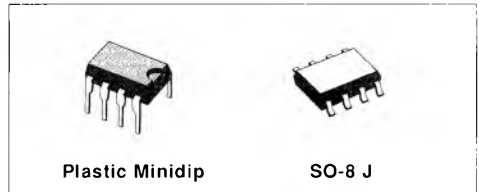

Plastic Minidip

SO-8 J

BLOCK DIAGRAM

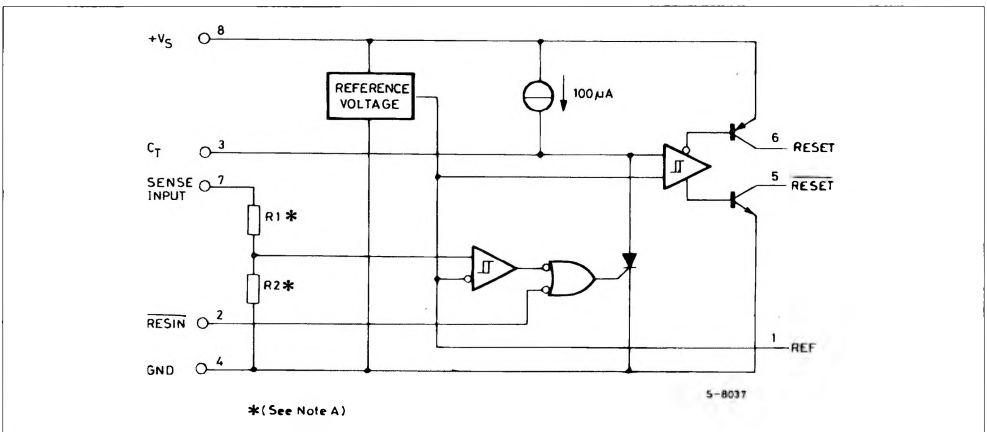

*(See Note A)

5-8037

* TL7702A R1 = 0 Ω , R2 = open; TL7705A R1 = 7.8 K Ω , R2 = 10 K Ω ; TL7709A R1 = 19.7 K Ω , R2 = 10 K Ω ; TL7712A R1 = 32.7 K Ω , R2 = 10 K Ω ; TL7715A R1 = 43.4 K Ω , R2 = 10 K Ω .

ABSOLUTE MAXIMUM RATINGS

Symbol	Parameter	Value	Unit
V _S	Supply Voltage, V _{CC} (see note 1)	20	V
V _i	Input Voltage Range at RESIN	- 0.3 to 20	V
V _i	Input Voltage at SENSE : TL7702A (see note 2) TL7705A TL7709A TL7712A TL7715A	- 0.3 to 6 - 0.3 to 10 - 0.3 to 15 - 0.3 to 20 - 0.3 to 20	V V V V V
I _{OH}	High-level Output Current at RESET	- 30	mA
I _{OL}	Low-level Output Current at RESET	30	mA
T _{amb}	Operating Free-air Temperature Range : TL77XXAI TL77XXAC	- 25 to 85 0 to 70	°C °C
T _{stg}	Storage Temperature Range	- 65 to 150	°C

Notes : 1. All voltage values are with respect to the network ground terminal.
2. For the TL7700A, the voltage applied to the SENSE terminal must never exceed V_S.

RECOMMENDED OPERATING CONDITIONS

Symbol	Parameter	Min.	Max.	Unit
V _S	Supply Voltage	3.6	18	V
V _{IH}	High-level Input Voltage at RESIN	2		V
V _{IL}	Low-level Input Voltage at RESIN		0.6	V
V _i	Voltage at Sense Input	TL7702A 0 TL7705A 0 TL7709A 0 TL7712A 0 TL7715A 0	See Note 3 10 15 20 20	V
I _{OH}	High-level Output Current at RESET		- 16	mA
I _{OL}	Low-level Output Current at RESET		16	mA
T _{amb}	Operating Free-air Temperature Range	TL77 - AI - 25 TL77 - AC 0	85 70	°C

Note : 3. For proper operation of the TL7702A, the voltage applied to the SENSE terminal should not exceed V_S - 1 V or 6 V, whichever is less.

CONNECTION DIAGRAM AND ORDER CODE

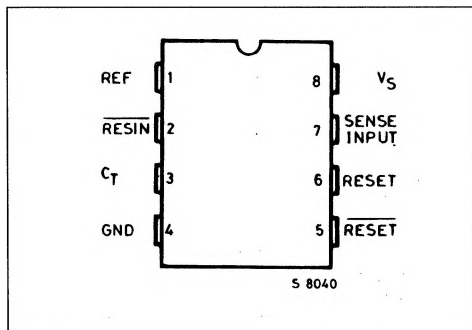

Temperature Range	Plastic Minidip	S0-8
Commercial 0 to 70 °C	TL77XXACP	TL77XXACD
Industrial - 40 to 85 °C	TL77XXAIP	TL77XXAID

THERMAL DATA

$R_{th j-amb}$	Thermal Resistance Junction-ambient	Max.	120	°C/W
----------------	-------------------------------------	------	-----	------

ELECTRICAL CHARACTERISTICS these specifications unless otherwise specified, apply for :
 $T_{amb} = -25$ to 85 °C (TLXXAI) ; $T_{amb} = 0$ to 70 °C (TL77XXAC)

Symbol	Parameter		Test Conditions (1)	Min.	Typ.	Max.	Unit
V_{OH}	High-level Output Voltage at RESET		$I_{OH} = -16$ mA	$V_S - 1.5$			V
V_{OL}	Low-Level Output Voltage at RESET		$I_{OL} = 16$ mA			0.4	V
V_{ref}	Reference Voltage		$T_{amb} = 25$ °C	2.48	2.53	2.58	V
V_T	Threshold Voltage at SENSE Input	TL7702A	$V_S = 3.6$ V to 18 V $T_{amb} = 25$ °C	2.48	2.53	2.58	V
		TL7705A		4.5	4.55	4.6	
		TL7709A		7.5	7.6	7.7	
		TL7712A		10.6	10.8	11.0	
		TL7715A		13.2	13.5	13.8	
V_T	Threshold Voltage at SENSE Input	TL7702A	$V_S = 3.6$ V to 18 V	2.45	2.53	2.58	V
		TL7705A		4.45	4.55	4.6	
		TL7709A		7.4	7.6	7.7	
		TL7712A		10.4	10.8	11.0	
		TL7715A		13.0	13.5	13.8	
V_{T+}, V_{T-}	Hysteresis (2) at SENSE Input	TL7702A	$V_S = 3.6$ V to 18 V $T_{amb} = 25$ °C		10		mV
		TL7705A			15		
		TL7709A			20		
		TL7712A			35		
		TL7715A			45		
I_i	Input Current at RESIN Input		$V_i = 2.4$ V to V_S			20	μ A
			$V_i = 0.4$ V			- 100	
I_i	Input Current at SENSE Input	TL7702A	$V_{ref} < V_i < V_S - 1.5$ V		0.5	2	
I_{OH}	High-level Output Current at RESET		$V_O = 18$ V			50	
I_{OL}	Low-level Output Current at RESET		$V_O = 0$ V			- 50	
I_S	Supply Current		All Inputs and out. open		1.8	3.3	

- Notes :**
1. All characteristics are measured with $C = 0.1$ μ F from Pin 1 to GND, and with $C = 0.1$ μ F from Pin 3 to GND.
 2. Hysteresis is the difference between the positive going input threshold voltage, V_{T+} , and the negative going input threshold voltage, V_{T-} .

SWITCHING CHARACTERISTICS

Symbol	Parameter	Test Conditions	Min.	Typ.	Max.	Unit
t_{pi}	Pulse Width at SENSE Input	$V_{ih} = V_{ityp} + 0.04 \times V_i$ $V_{il} = V_{ityp} - 0.04 \times V_i$	0.9			μs
t_{pi}	Pulse Width at RESIN Input		0.4			μs
t_{po}	Pulse Width at Output	$C_L = 0.1 \mu F$	0.65	1.3	2.6	ms
t_{pdHL}	Propagation Delay Time from RESIN to RESET	$C_L = 100 pF$ $V_S = 5 V$ $R_L = 4.7 K\Omega$			1	μs
$t_{r/f}$	Rise/Falltime at RESET and RESET	$C_L = 10 pF$ $V_S = 5 V$ $R_L = 4.7 K\Omega$			1	μs

Figure 1 : Multiple Power Supply System Reset Generation.

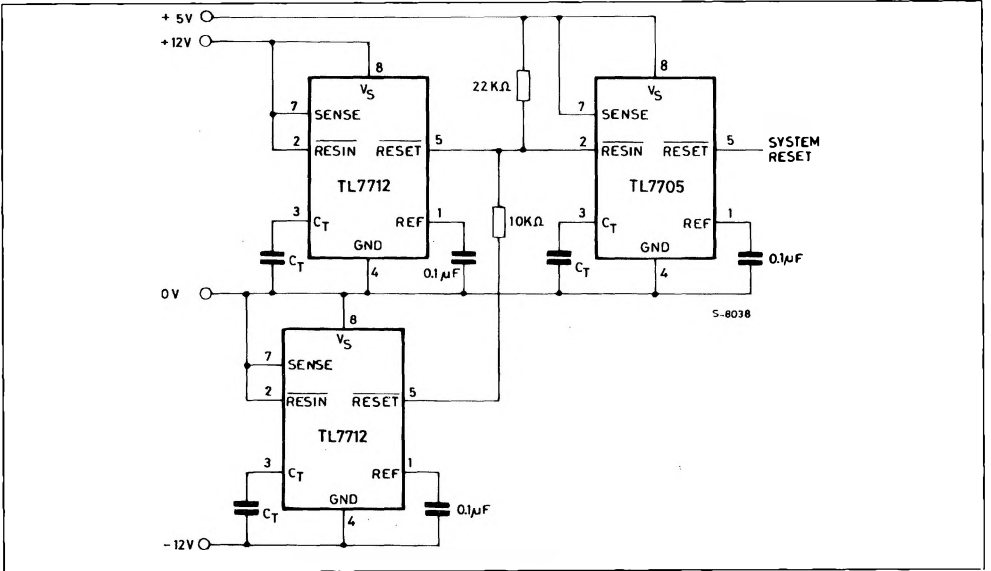

Figure 2 : Reset Controller for μ P.

