

TL75LPxxQ SERIES TL75LPxxY SERIES LOW-DROPOUT VOLTAGE REGULATORS

SLVS073A – SEPTEMBER 1992 – REVISED AUGUST 1995

- Very Low-Dropout Voltage . . . Less Than 400 mV at 300 mA
- Standby Mode Reduces Current to a Maximum of 150 μ A
- Output Regulated to Within $\pm 2\%$ Over Full Temperature Range
- Packaged in Thin Shrink Small-Outline Package
- Only 10- μ F Load Capacitor Required to Maintain Regulation at $I_O = 300$ mA

description

The TL75LPxxQ devices are low-dropout voltage regulators specifically targeted for use in portable applications. These devices generate fixed output voltages at loads of up to 300 mA with only 400-mV dropout over the full temperature range.

Low-dropout voltage regulators are commonly used in battery-powered systems such as analog and digital cellular phones. The TL75LPxx family of regulators feature a TTL/CMOS-compatible enable terminal, which can be used to switch the device into standby mode. This feature reduces power consumption when the instrument is not active. Less than 150 μ A is required when the unit is disabled.

A concern in many new designs is conservation of board space and overall reduction in equipment size. The thin shrink small-outline package (TSSOP) minimizes board area and reduces component height. This package has a maximum height of less than 1.1 mm (compared to the 1.75 mm of a standard 8-pin SO package) and dimensions of only 6.5 mm by 4.4 mm.

All low-dropout regulators require an external capacitor at the output to maintain regulation and stability. To further reduce board area and cost, the TL75LPxx devices are designed to require a minimum capacitor of only 10 μ F. This is 1/10 the typical value used by many other low-dropout regulators. To simplify the task of choosing a suitable capacitor, TI has included in this datasheet a list of recommended capacitors for use with these devices.

The TL75LPxxQ devices are characterized for operation over $T_J = -40^\circ\text{C}$ to 125°C .

AVAILABLE OPTIONS

T_J	V_O			PACKAGED DEVICES	CHIP FORM (Y)
	MIN	TYP	MAX	TSSOP (PW)	
-40°C to 125°C	4.75	4.85	4.95	TL75LP48QPWLE	TL75LP48Y
	4.9	5	5.1	TL75LP05QPWLE	TL75LP05Y
	7.84	8	8.16	TL75LP08QPWLE	TL75LP08Y
	9.8	10	10.2	TL75LP10QPWLE	TL75LP10Y
	11.76	12	12.24	TL75LP12QPWLE	TL75LP12Y

The PW package is available only in tape and reel. Chip forms are tested at 25°C .

PW PACKAGE (TOP VIEW)

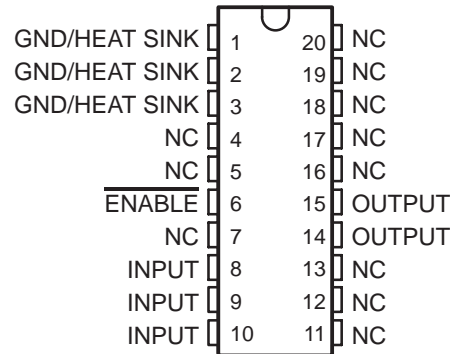

GND/HEAT SINK – These terminals have an internal connection to ground and must be grounded.
NC – No internal connection

† The PW package is only available in left-end taped and reeled (order device TL75LPxxQPWLE).

typical application schematic

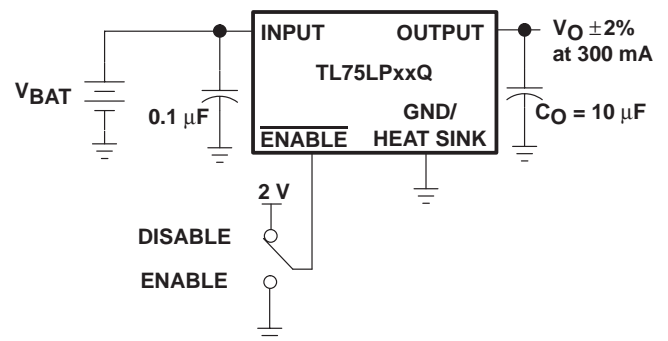

PRODUCTION DATA information is current as of publication date. Products conform to specifications per the terms of Texas Instruments standard warranty. Production processing does not necessarily include testing of all parameters.



Copyright © 1995, Texas Instruments Incorporated

TL75LPxxQ SERIES TL75LPxxY SERIES LOW-DROPOUT VOLTAGE REGULATORS

SLVS073A – SEPTEMBER 1992 – REVISED AUGUST 1995

functional block diagram

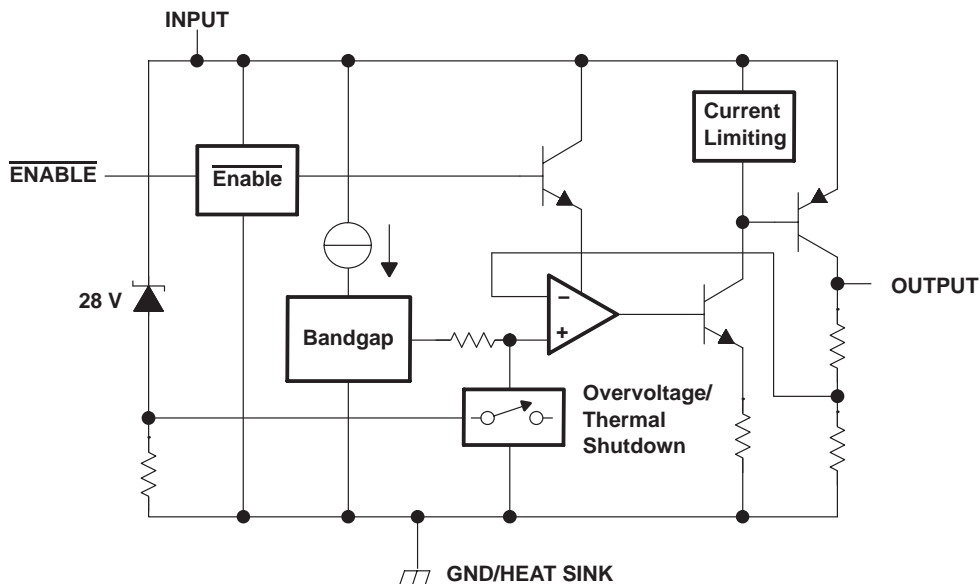

TL75LPxxY chip information

This chip, when properly assembled, displays characteristics similar to the TL75LPxx. Thermal compression or ultrasonic bonding can be used on the doped aluminum bonding pads. The chip can be mounted with conductive epoxy or a gold-silicon preform.

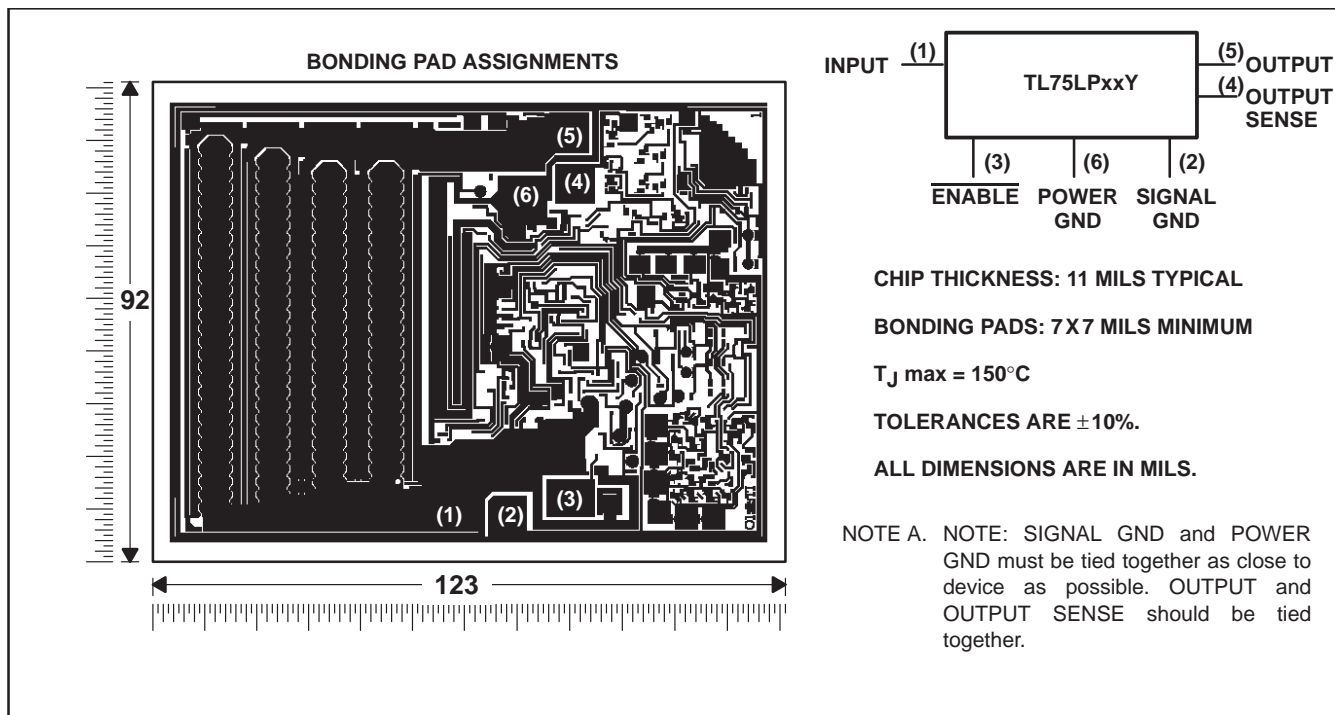

TL75LPxxQ SERIES
TL75LPxxY SERIES
LOW-DROPOUT VOLTAGE REGULATORS

SLVS073A – SEPTEMBER 1992 – REVISED AUGUST 1995

absolute maximum ratings over operating free-air temperature range (unless otherwise noted)†

Supply voltage, V_{CC} , (See Note 1)	25 V
Output current, I_O	400 mA
Operating virtual junction temperature range, T_J	-55°C to 150°C
Continuous total power dissipation (see Note 2)	See Dissipation Rating Table
Storage temperature range, T_{stg}	-65°C to 150°C
Lead temperature 1,6 mm (1/16 inch) from case for 10 seconds	260°C

† Stresses beyond those listed under “absolute maximum ratings” may cause permanent damage to the device. These are stress ratings only, and functional operation of the device at these or any other conditions beyond those indicated under “recommended operating conditions” is not implied. Exposure to absolute-maximum-rated conditions for extended periods may affect device reliability.

- NOTES: 1. All voltage values are with respect to network terminal ground.
 2. Refer to Figures 1 and 2 to avoid exceeding the design maximum virtual junction temperature; these ratings should not be exceeded. Due to variation in individual device electrical characteristics and thermal resistance, the built-in thermal overload protection may be activated at power levels slightly above or below the rated dissipation.

DISSIPATION RATING TABLE

PACKAGE	POWER RATING AT	$T \leq 25^\circ\text{C}$ POWER RATING	DERATING FACTOR ABOVE $T = 25^\circ\text{C}$	$T = 70^\circ\text{C}$ POWER RATING	$T = 85^\circ\text{C}$ POWER RATING	$T = 125^\circ\text{C}$ POWER RATING
PW	T_A	828 mW	6.62 mW/°C	530 mW	431 mW	166 mW
	T_C	4032 mW	32.2 mW/°C	2583 mW	2100 mW	812 mW
	T_P ‡	2475 mW	19.8 mW/°C	1584 mW	1287 mW	495 mW

‡ $R_{\theta JP}$ is the thermal resistance between the junction and the device pin. To determine the virtual junction temperature (T_J) relative to the device pin temperature, the following calculations should be used: $T_J = P_D \times R_{\theta JP} + T_P$, where P_D is the internal power dissipation of the device and T_P is the device pin temperature at the point of contact to the printed wiring board. The $R_{\theta JP}$ for the TL75LPxx series is 50.5°C/W.

**MAXIMUM CONTINUOUS DISSIPATION
vs
FREE-AIR TEMPERATURE**

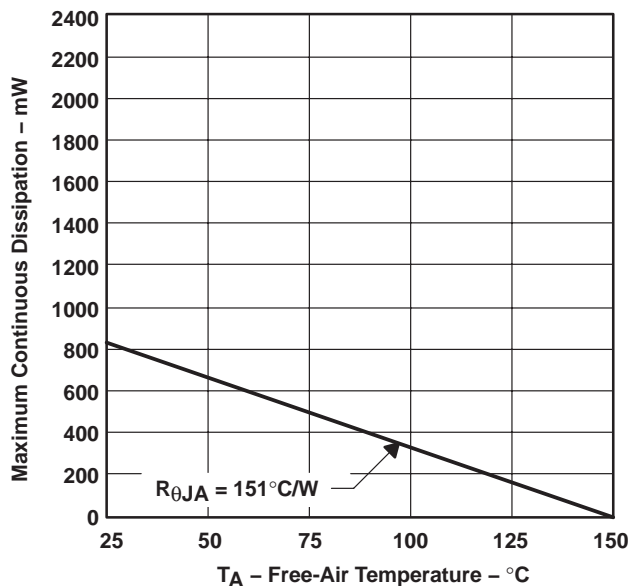

Figure 1

**MAXIMUM CONTINUOUS DISSIPATION
vs
CASE TEMPERATURE**

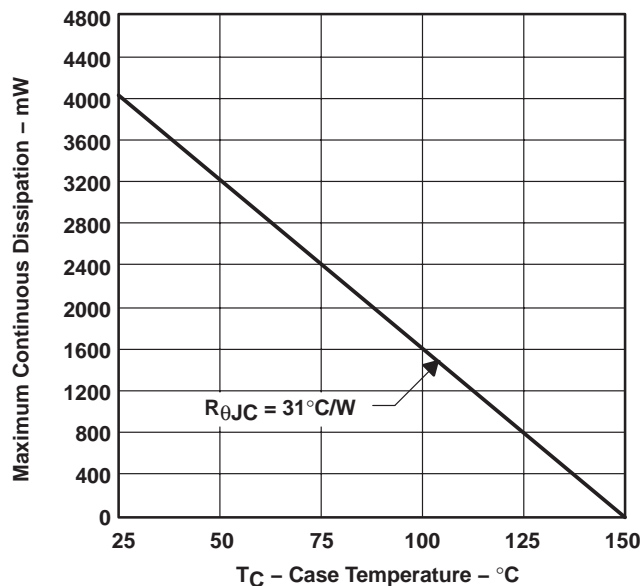

Figure 2



TL75LPxxQ SERIES
TL75LPxxY SERIES
LOW-DROPOUT VOLTAGE REGULATORS

SLVS073A – SEPTEMBER 1992 – REVISED AUGUST 1995

recommended operating conditions

		MIN	MAX	UNIT
Input voltage, V_I	TL75LP48	5.15	23.0	V
	TL75LP05	5.3	23.0	
	TL75LP08	8.4	23.0	
	TL75LP10	10.4	23.0	
	TL75LP12	12.5	23.0	
High-level input voltage, $\overline{\text{ENABLE}}$, V_{IH}		2.0	15.0	V
Low-level input voltage, $\overline{\text{ENABLE}}$, V_{IL}		0	0.8	V
Output current range, I_O		5	300	mA
Operating virtual junction temperature range, T_J		-40	125	°C

electrical characteristics over operating virtual junction temperature range, $V_I = 10\text{ V}$, $I_O = 300\text{ mA}$, $\overline{\text{ENABLE}} = 0\text{ V}$ (unless otherwise noted)

PARAMETER	TEST CONDITIONS†	TL75LP48Q			UNIT
		MIN	TYP	MAX	
Output voltage	$V_I = 5.35\text{ V to }10\text{ V}$	4.75	4.85	4.95	V
Input voltage regulation	$V_I = 5.35\text{ V to }10\text{ V}$, $T_J = 25^\circ\text{C}$		10	25	mV
Ripple rejection	$V_I = 5.6\text{ V to }15.6\text{ V}$, $f = 120\text{ Hz}$, $T_J = 25^\circ\text{C}$	50	55		dB
Output voltage regulation	$I_O = 5\text{ mA to }300\text{ mA}$, $T_J = 25^\circ\text{C}$		12	30	mV
Dropout voltage	$I_O = 100\text{ mA}$		0.12	0.2	V
	$I_O = 200\text{ mA}$		0.17	0.3	
	$I_O = 300\text{ mA}$		0.22	0.4	
Output noise voltage	$f = 10\text{ Hz to }100\text{ kHz}$, $T_J = 25^\circ\text{C}$		500		μV
Bias current	$I_O = 10\text{ mA}$		2.5	4	mA
	$I_O = 100\text{ mA}$		4	10	
	$I_O = 200\text{ mA}$		6	20	
	$I_O = 300\text{ mA}$		9	30	
High-level input current, $\overline{\text{ENABLE}}$	$\overline{\text{ENABLE}} = 0.8\text{ V}$		7	25	μA
Low-level input current, $\overline{\text{ENABLE}}$	$\overline{\text{ENABLE}} = 2\text{ V}$		0.05	6	μA
Standby current	$\overline{\text{ENABLE}} = 2\text{ V}$		100	150	μA

† Pulse-testing techniques maintain the virtual junction temperature as close to the ambient temperature as possible. Thermal effects must be taken into account separately. All characteristics are measured with a 0.1- μF capacitor across the input and a 10- μF capacitor with equivalent series resistance within the guidelines shown in Figures 3 and 4 on the output. All measurements are taken with a tantalum electrolytic capacitor. Although not normally recommended, an aluminum electrolytic capacitor can be used. Attention must be given its ESR value, particularly at low temperatures.

TL75LPxxQ SERIES
TL75LPxxY SERIES
LOW-DROPOUT VOLTAGE REGULATORS

SLVS073A – SEPTEMBER 1992 – REVISED AUGUST 1995

electrical characteristics over operating virtual junction temperature range, $V_I = 10\text{ V}$, $I_O = 300\text{ mA}$, $\overline{\text{ENABLE}} = 0\text{ V}$ (unless otherwise noted)

PARAMETER	TEST CONDITION [†]	TL75LP05Q			UNIT
		MIN	TYP	MAX	
Output voltage	$V_I = 5.5\text{ V to }10\text{ V}$	4.9	5	5.1	V
Input voltage regulation	$V_I = 5.5\text{ V to }10\text{ V}$, $T_J = 25^\circ\text{C}$		10	25	mV
Ripple rejection	$V_I = 6\text{ V to }16\text{ V}$, $f = 120\text{ Hz}$, $T_J = 25^\circ\text{C}$	50	55		dB
Output voltage regulation	$I_O = 5\text{ mA to }300\text{ mA}$, $T_J = 25^\circ\text{C}$		12	30	mV
Dropout voltage	$I_O = 100\text{ mA}$		0.12	0.2	V
	$I_O = 200\text{ mA}$		0.17	0.3	
	$I_O = 300\text{ mA}$		0.22	0.4	
Output noise voltage	$f = 10\text{ Hz to }100\text{ kHz}$, $T_J = 25^\circ\text{C}$		500		μV
Bias current	$I_O = 10\text{ mA}$		2.5	4	mA
	$I_O = 100\text{ mA}$		4	10	
	$I_O = 200\text{ mA}$		6	20	
	$I_O = 300\text{ mA}$		9	30	
High-level input current, $\overline{\text{ENABLE}}$	$\overline{\text{ENABLE}} = 0.8\text{ V}$		7	25	μA
Low-level input current, $\overline{\text{ENABLE}}$	$\overline{\text{ENABLE}} = 2\text{ V}$		0.05	6	μA
Standby current	$\overline{\text{ENABLE}} = 2\text{ V}$		100	150	μA

[†] Pulse-testing techniques maintain the virtual junction temperature as close to the ambient temperature as possible. Thermal effects must be taken into account separately. All characteristics are measured with a 0.1- μF capacitor across the input and a 10- μF capacitor with equivalent series resistance within the guidelines shown in Figures 3 and 4 on the output. All measurements are taken with a tantalum electrolytic capacitor. Although not normally recommended, an aluminum electrolytic capacitor can be used. Attention must be given its ESR value, particularly at low temperatures.

electrical characteristics over operating virtual junction temperature range, $V_I = 10\text{ V}$, $I_O = 300\text{ mA}$, $\overline{\text{ENABLE}} = 0\text{ V}$ (unless otherwise noted)

PARAMETER	TEST CONDITION [†]	TL75LP08Q			UNIT
		MIN	TYP	MAX	
Output voltage	$V_I = 8.6\text{ V to }15\text{ V}$	7.84	8	8.16	V
Input voltage regulation	$V_I = 8.6\text{ V to }15\text{ V}$, $T_J = 25^\circ\text{C}$		12	40	mV
Ripple rejection	$V_I = 9\text{ V to }19\text{ V}$, $f = 120\text{ Hz}$, $T_J = 25^\circ\text{C}$	50	55		dB
Output voltage regulation	$I_O = 5\text{ mA to }300\text{ mA}$, $T_J = 25^\circ\text{C}$		12	40	mV
Dropout voltage	$I_O = 100\text{ mA}$		0.12	0.2	V
	$I_O = 200\text{ mA}$		0.17	0.3	
	$I_O = 300\text{ mA}$		0.22	0.4	
Output noise voltage	$f = 10\text{ Hz to }100\text{ kHz}$, $T_J = 25^\circ\text{C}$		500		μV
Bias current	$I_O = 10\text{ mA}$		2.5	4	mA
	$I_O = 100\text{ mA}$		4	10	
	$I_O = 200\text{ mA}$		6	20	
	$I_O = 300\text{ mA}$		9	30	
High-level input current, $\overline{\text{ENABLE}}$	$\overline{\text{ENABLE}} = 0.8\text{ V}$		7	25	μA
Low-level input current, $\overline{\text{ENABLE}}$	$\overline{\text{ENABLE}} = 2\text{ V}$		0.05	6	μA
Standby current	$\overline{\text{ENABLE}} = 2\text{ V}$		100	150	μA

[†] Pulse-testing techniques maintain the virtual junction temperature as close to the ambient temperature as possible. Thermal effects must be taken into account separately. All characteristics are measured with a 0.1- μF capacitor across the input and a 10- μF capacitor with equivalent series resistance within the guidelines shown in Figures 3 and 4 on the output. All measurements are taken with a tantalum electrolytic capacitor. Although not normally recommended, an aluminum electrolytic capacitor can be used. Attention must be given its ESR value, particularly at low temperatures.



TL75LPxxQ SERIES TL75LPxxY SERIES LOW-DROPOUT VOLTAGE REGULATORS

SLVS073A – SEPTEMBER 1992 – REVISED AUGUST 1995

electrical characteristics over operating virtual junction temperature range, $V_I = 14\text{ V}$, $I_O = 300\text{ mA}$, $\overline{\text{ENABLE}} = 0\text{ V}$ (unless otherwise noted)

PARAMETER	TEST CONDITION†	TL75LP10Q			UNIT
		MIN	TYP	MAX	
Output voltage	$V_I = 10.6\text{ V to }17\text{ V}$	9.8	10	10.2	V
Input voltage regulation	$V_I = 10.6\text{ V to }17\text{ V}$, $T_J = 25^\circ\text{C}$		15	43	mV
Ripple rejection	$V_I = 11\text{ V to }21\text{ V}$, $f = 120\text{ Hz}$, $T_J = 25^\circ\text{C}$	50	55		dB
Output voltage regulation	$I_O = 5\text{ mA to }300\text{ mA}$, $T_J = 25^\circ\text{C}$		15	50	mV
Dropout voltage	$I_O = 100\text{ mA}$		0.12	0.2	V
	$I_O = 200\text{ mA}$		0.17	0.3	
	$I_O = 300\text{ mA}$		0.22	0.4	
Output noise voltage	$f = 10\text{ Hz to }100\text{ kHz}$, $T_J = 25^\circ\text{C}$		1000		μV
Bias current	$I_O = 10\text{ mA}$		2.5	4	mA
	$I_O = 100\text{ mA}$		4	10	
	$I_O = 200\text{ mA}$		6	20	
	$I_O = 300\text{ mA}$		9	30	
High-level input current, $\overline{\text{ENABLE}}$	$\overline{\text{ENABLE}} = 0.8\text{ V}$		7	25	μA
Low-level input current, $\overline{\text{ENABLE}}$	$\overline{\text{ENABLE}} = 2\text{ V}$		0.05	6	μA
Standby current	$\overline{\text{ENABLE}} = 2\text{ V}$		100	150	μA

† Pulse-testing techniques maintain the virtual junction temperature as close to the ambient temperature as possible. Thermal effects must be taken into account separately. All characteristics are measured with a 0.1- μF capacitor across the input and a 10- μF capacitor with equivalent series resistance within the guidelines shown in Figures 3 and 4 on the output. All measurements are taken with a tantalum electrolytic capacitor. Although not normally recommended, an aluminum electrolytic capacitor can be used. Attention must be given its ESR value, particularly at low temperatures.

electrical characteristics over operating virtual junction temperature range, $V_I = 14\text{ V}$, $I_O = 300\text{ mA}$, $\overline{\text{ENABLE}} = 0\text{ V}$ (unless otherwise noted)

PARAMETER	TEST CONDITION†	TL75LP12Q			UNIT
		MIN	TYP	MAX	
Output voltage	$V_I = 12.7\text{ V to }18\text{ V}$	11.76	12	12.24	V
Input voltage regulation	$V_I = 12.7\text{ V to }18\text{ V}$, $T_J = 25^\circ\text{C}$		15	43	mV
Ripple rejection	$V_I = 13\text{ V to }23\text{ V}$, $f = 120\text{ Hz}$, $T_J = 25^\circ\text{C}$	50	55		dB
Output voltage regulation	$I_O = 5\text{ mA to }300\text{ mA}$, $T_J = 25^\circ\text{C}$		15	60	mV
Dropout voltage	$I_O = 100\text{ mA}$		0.12	0.2	V
	$I_O = 200\text{ mA}$		0.17	0.3	
	$I_O = 300\text{ mA}$		0.22	0.4	
Output noise voltage	$f = 10\text{ Hz to }100\text{ kHz}$, $T_J = 25^\circ\text{C}$		1000		μV
Bias current	$I_O = 10\text{ mA}$		2.5	4	mA
	$I_O = 100\text{ mA}$		4	10	
	$I_O = 200\text{ mA}$		6	20	
	$I_O = 300\text{ mA}$		9	30	
High-level input current, $\overline{\text{ENABLE}}$	$\overline{\text{ENABLE}} = 0.8\text{ V}$		7	25	μA
Low-level input current, $\overline{\text{ENABLE}}$	$\overline{\text{ENABLE}} = 2\text{ V}$		0.05	6	μA
Standby current	$\overline{\text{ENABLE}} = 2\text{ V}$		100	150	μA

† Pulse-testing techniques maintain the virtual junction temperature as close to the ambient temperature as possible. Thermal effects must be taken into account separately. All characteristics are measured with a 0.1- μF capacitor across the input and a 10- μF capacitor with equivalent series resistance within the guidelines shown in Figures 3 and 4 on the output. All measurements are taken with a tantalum electrolytic capacitor. Although not normally recommended, an aluminum electrolytic capacitor can be used. Attention must be given its ESR value, particularly at low temperatures.



TL75LPxxQ SERIES
TL75LPxxY SERIES
LOW-DROPOUT VOLTAGE REGULATORS

SLVS073A – SEPTEMBER 1992 – REVISED AUGUST 1995

electrical characteristics at $V_I = 10\text{ V}$, $I_O = 300\text{ mA}$, $\overline{\text{ENABLE}} = 0\text{ V}$, $T_J = 25^\circ\text{C}$ (unless otherwise noted)

PARAMETER	TEST CONDITIONS†	TL75LP48Y			UNIT
		MIN	TYP	MAX	
Output voltage			4.85		V
Input voltage regulation			10		mV
Ripple rejection	$f = 120\text{ Hz}$		55		dB
Output voltage regulation			12		mV
Dropout voltage			0.22		V
Output noise voltage	$f = 10\text{ Hz to }100\text{ kHz}$		500		μV
Bias current			9		mA
High-level input current, $\overline{\text{ENABLE}}$	$\overline{\text{ENABLE}} = 0.8\text{ V}$		7		μA
Low-level input current, $\overline{\text{ENABLE}}$	$\overline{\text{ENABLE}} = 2\text{ V}$		0.05		μA
Standby current	$\overline{\text{ENABLE}} = 2\text{ V}$		100		μA

† Pulse-testing techniques maintain the virtual junction temperature as close to the ambient temperature as possible. Thermal effects must be taken into account separately. All characteristics are measured with a 0.1- μF capacitor across the input and a 10- μF capacitor with equivalent series resistance within the guidelines shown in Figures 3 and 4 on the output. All measurements are taken with a tantalum electrolytic capacitor. Although not normally recommended, an aluminum electrolytic capacitor can be used. Attention must be given its ESR value, particularly at low temperatures.

electrical characteristics at $V_I = 10\text{ V}$, $I_O = 300\text{ mA}$, $\overline{\text{ENABLE}} = 0\text{ V}$, $T_J = 25^\circ\text{C}$ (unless otherwise noted)

PARAMETER	TEST CONDITIONS†	TL75LP05Y			UNIT
		MIN	TYP	MAX	
Output voltage			5		V
Input voltage regulation			10		mV
Ripple rejection	$f = 120\text{ Hz}$		55		dB
Output voltage regulation			12		mV
Dropout voltage			0.22		V
Output noise voltage	$f = 10\text{ Hz to }100\text{ kHz}$		500		μV
Bias current			9		mA
High-level input current, $\overline{\text{ENABLE}}$	$\overline{\text{ENABLE}} = 0.8\text{ V}$		7		μA
Low-level input current, $\overline{\text{ENABLE}}$	$\overline{\text{ENABLE}} = 2\text{ V}$		0.05		μA
Standby current	$\overline{\text{ENABLE}} = 2\text{ V}$		100		μA

† Pulse-testing techniques maintain the virtual junction temperature as close to the ambient temperature as possible. Thermal effects must be taken into account separately. All characteristics are measured with a 0.1- μF capacitor across the input and a 10- μF capacitor with equivalent series resistance within the guidelines shown in Figures 3 and 4 on the output. All measurements are taken with a tantalum electrolytic capacitor. Although not normally recommended, an aluminum electrolytic capacitor can be used. Attention must be given its ESR value, particularly at low temperatures.



TL75LPxxQ SERIES
TL75LPxxY SERIES
LOW-DROPOUT VOLTAGE REGULATORS

SLVS073A – SEPTEMBER 1992 – REVISED AUGUST 1995

electrical characteristics at $V_I = 10\text{ V}$, $I_O = 300\text{ mA}$, $\overline{\text{ENABLE}} = 0\text{ V}$, $T_J = 25^\circ\text{C}$ (unless otherwise noted)

PARAMETER	TEST CONDITIONS†	TL75LP08Y			UNIT
		MIN	TYP	MAX	
Output voltage			8		V
Input voltage regulation			12		mV
Ripple rejection	$f = 120\text{ Hz}$		55		dB
Output voltage regulation			12		mV
Dropout voltage			0.22		V
Output noise voltage	$f = 10\text{ Hz to }100\text{ kHz}$		500		μV
Bias current			9		mA
High-level input current, $\overline{\text{ENABLE}}$	$\overline{\text{ENABLE}} = 0.8\text{ V}$		7		μA
Low-level input current, $\overline{\text{ENABLE}}$	$\overline{\text{ENABLE}} = 2\text{ V}$		0.05		μA
Standby current	$\overline{\text{ENABLE}} = 2\text{ V}$		100		μA

† Pulse-testing techniques maintain the virtual junction temperature as close to the ambient temperature as possible. Thermal effects must be taken into account separately. All characteristics are measured with a 0.1- μF capacitor across the input and a 10- μF capacitor with equivalent series resistance within the guidelines shown in Figures 3 and 4 on the output. All measurements are taken with a tantalum electrolytic capacitor. Although not normally recommended, an aluminum electrolytic capacitor can be used. Attention must be given its ESR value, particularly at low temperatures.

electrical characteristics at $V_I = 14\text{ V}$, $I_O = 300\text{ mA}$, $\overline{\text{ENABLE}} = 0\text{ V}$, $T_J = 25^\circ\text{C}$ (unless otherwise noted)

PARAMETER	TEST CONDITIONS†	TL75LP10Y			UNIT
		MIN	TYP	MAX	
Output voltage			10		V
Input voltage regulation			15		mV
Ripple rejection	$f = 120\text{ Hz}$		55		dB
Output voltage regulation			15		mV
Dropout voltage			0.22		V
Output noise voltage	$f = 10\text{ Hz to }100\text{ kHz}$		1000		μV
Bias current			9		mA
High-level input current, $\overline{\text{ENABLE}}$	$\overline{\text{ENABLE}} = 0.8\text{ V}$		7		μA
Low-level input current, $\overline{\text{ENABLE}}$	$\overline{\text{ENABLE}} = 2\text{ V}$		0.05		μA
Standby current	$\overline{\text{ENABLE}} = 2\text{ V}$		100		μA

† Pulse-testing techniques maintain the virtual junction temperature as close to the ambient temperature as possible. Thermal effects must be taken into account separately. All characteristics are measured with a 0.1- μF capacitor across the input and a 10- μF capacitor with equivalent series resistance within the guidelines shown in Figures 3 and 4 on the output. All measurements are taken with a tantalum electrolytic capacitor. Although not normally recommended, an aluminum electrolytic capacitor can be used. Attention must be given its ESR value, particularly at low temperatures.



TL75LPxxQ SERIES
TL75LPxxY SERIES
LOW-DROPOUT VOLTAGE REGULATORS

SLVS073A – SEPTEMBER 1992 – REVISED AUGUST 1995

electrical characteristics at $V_I = 14\text{ V}$, $I_O = 300\text{ mA}$, $\overline{\text{ENABLE}} = 0\text{ V}$, $T_J = 25^\circ\text{C}$ (unless otherwise noted)

PARAMETER	TEST CONDITIONS†	TL75LP12Y			UNIT
		MIN	TYP	MAX	
Output voltage		11.76	12	12.24	V
Input voltage regulation			15	43	mV
Ripple rejection	$f = 120\text{ Hz}$		55		dB
Output voltage regulation			12	60	mV
Dropout voltage			0.22	0.4	V
Output noise voltage	$f = 10\text{ Hz to }100\text{ kHz}$		500		μV
Bias current			9	30	mA
High-level input current, $\overline{\text{ENABLE}}$	$\overline{\text{ENABLE}} = 0.8\text{ V}$		7	25	μA
Low-level input current, $\overline{\text{ENABLE}}$	$\overline{\text{ENABLE}} = 2\text{ V}$		0.05	6	μA
Standby current	$\overline{\text{ENABLE}} = 2\text{ V}$		100	150	μA

† Pulse-testing techniques maintain the virtual junction temperature as close to the ambient temperature as possible. Thermal effects must be taken into account separately. All characteristics are measured with a 0.1- μF capacitor across the input and a 10- μF capacitor with equivalent series resistance within the guidelines shown in Figures 3 and 4 on the output. All measurements are taken with a tantalum electrolytic capacitor. Although not normally recommended, an aluminum electrolytic capacitor can be used. Attention must be given its ESR value, particularly at low temperatures.



TL75LPxxQ SERIES TL75LPxxY SERIES LOW-DROPOUT VOLTAGE REGULATORS

SLVS073A – SEPTEMBER 1992 – REVISED AUGUST 1995

PARAMETER MEASUREMENT INFORMATION

The TL75LPxx series are low-dropout voltage regulators. This means that the capacitance is important to the performance of the regulator because it is a vital part of the control loop. The capacitor value and the equivalent series resistance (ESR) both affect the control loop and must be defined for the load range and the temperature range. Figures 3 and 4 can establish the capacitance value and ESR range for optimum regulator performance.

Figure 3 shows the recommended range of ESR, measured at 120 Hz, for a given load with a 10- μ F capacitor on the output. In addition, it shows a maximum ESR limit of 2 Ω and a load-dependent minimum ESR limit.

For applications with varying loads, the lightest load condition should be chosen since it is the worst case. Figure 4 shows the relationship of the reciprocal of ESR to the square root of the capacitance with a minimum capacitance limit of 10 μ F and a maximum ESR limit of 2 Ω . Figure 4 establishes the amount that the minimum ESR limit of Figure 3 can be adjusted for different capacitor values. For example, when the minimum load needed is 200 mA, Figure 3 suggests an ESR range of 0.8 Ω to 2 Ω for 10 μ F. Figure 4 shows that changing the capacitor from 10 μ F to 400 μ F can change the ESR minimum by greater than 3/0.5 (or 6). Therefore, the new minimum ESR value is 0.8/6 (or 0.13 Ω). This now allows an ESR range of 0.13 Ω to 2 Ω . This expanded ESR range is achieved by using a larger capacitor at the output. For better stability in low-current applications, it is recommended that a small resistance be placed in series with the capacitor (see Table 1) so that the ESR better approximates those in Figures 3 and 4.

Table 1. Compensations for Increased Stability at Low Currents

MANUFACTURER	CAPACITANCE	ESR TYP	PART NUMBER	ADDITIONAL RESISTANCE
AVX	15 μ F	0.9 Ω	TAJB156M010S	1 Ω
KEMET	33 μ F	0.6 Ω	T491D336M010AS	0.5 Ω

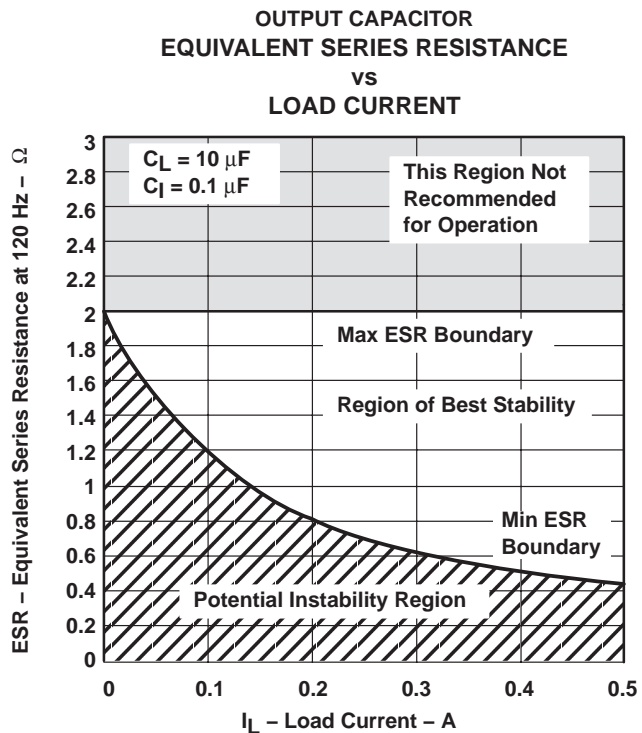
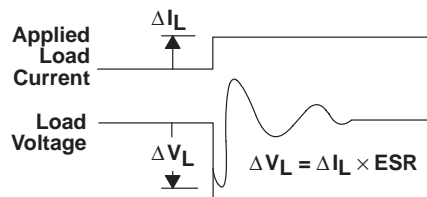

Figure 3

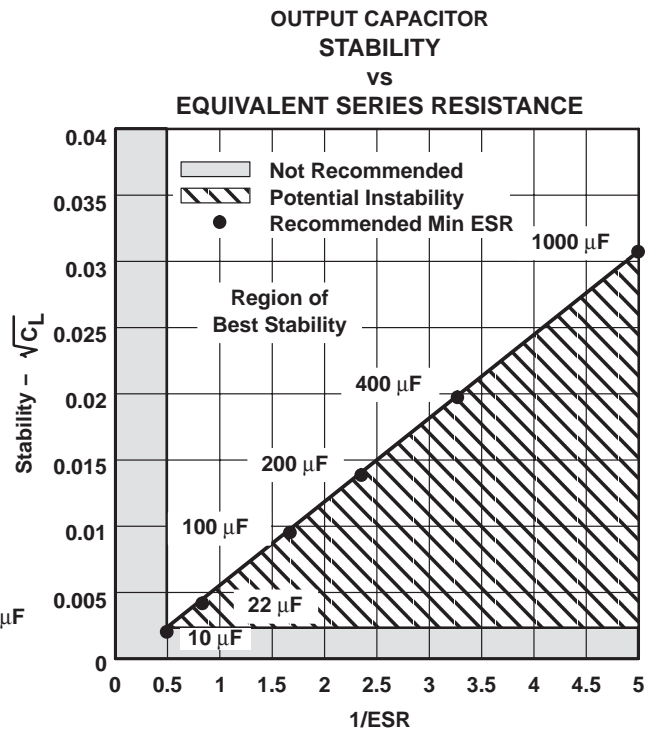

Figure 4

TYPICAL CHARACTERISTICS

Table of Graphs

			FIGURE
Output voltage		vs Input voltage	5
Input current	$I_O = 10 \text{ mA}$	vs Input voltage	6
	$I_O = 100 \text{ mA}$	vs Input voltage	7
Dropout voltage		vs Output current	8
Quiescent current		vs Output current	9
Short-circuit protection conditions output voltage		vs Output current	10
Load transient response			11
Line transient response			12

TL75LPxxQ SERIES
TL75LPxxY SERIES
LOW-DROPOUT VOLTAGE REGULATORS

SLVS073A – SEPTEMBER 1992 – REVISED AUGUST 1995

TYPICAL CHARACTERISTICS

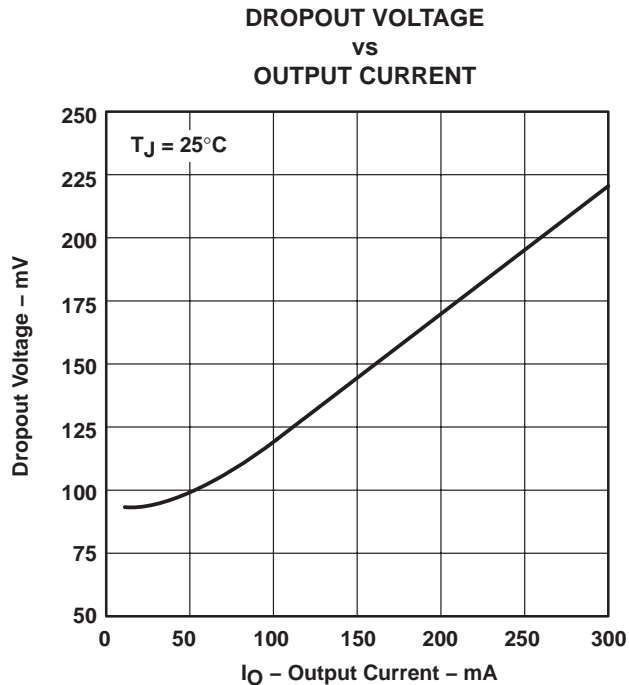
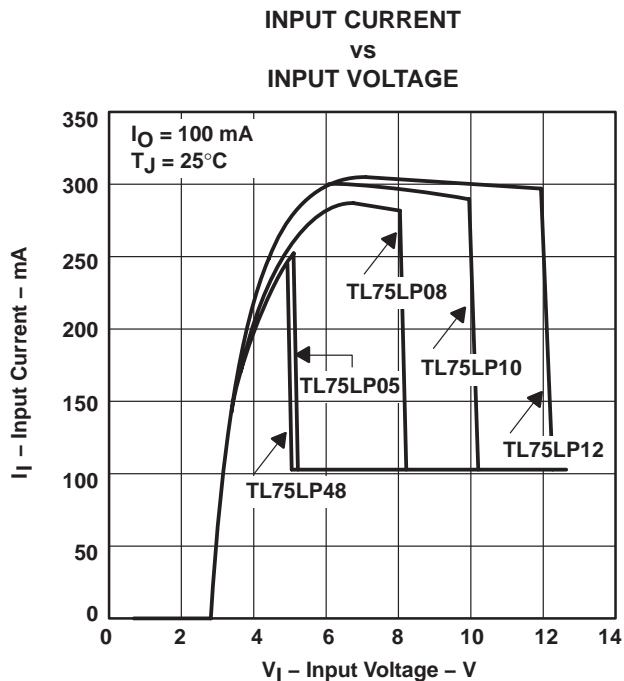
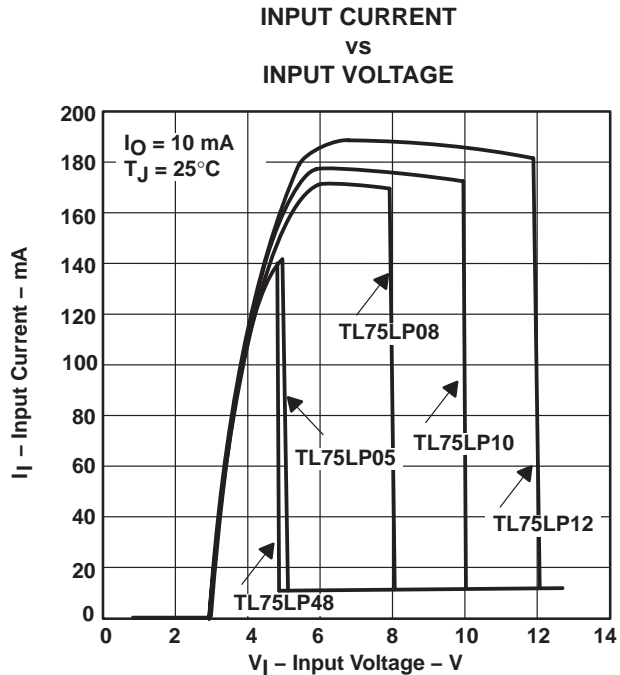
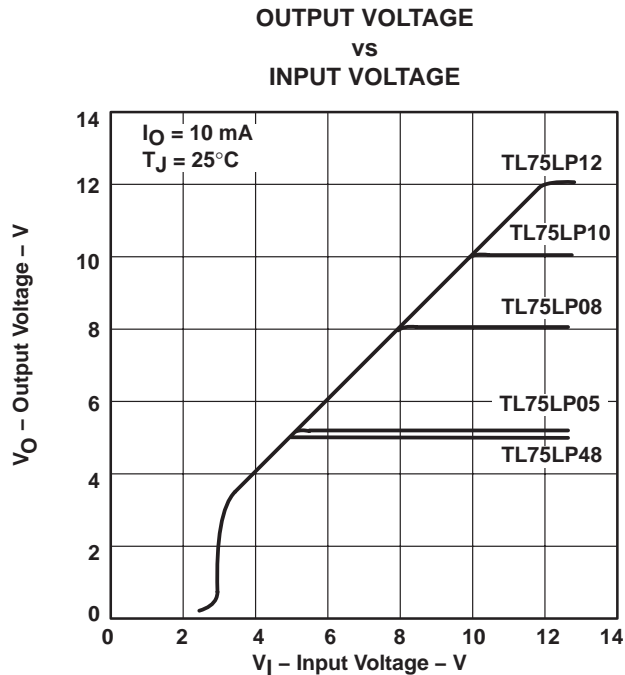

TYPICAL CHARACTERISTICS

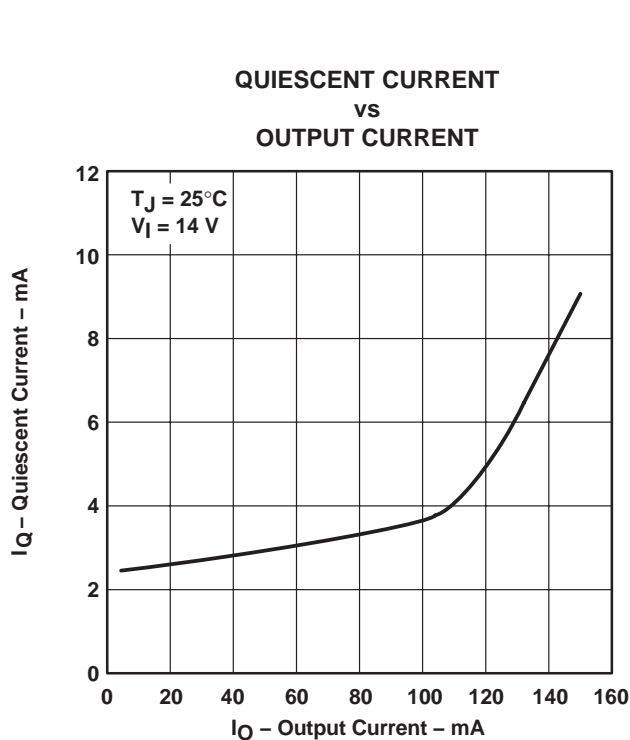

Figure 9

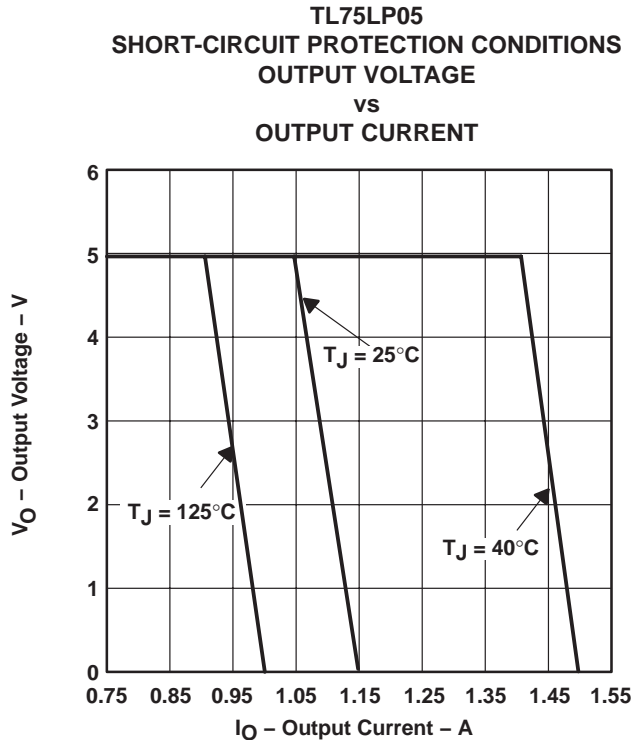

Figure 10

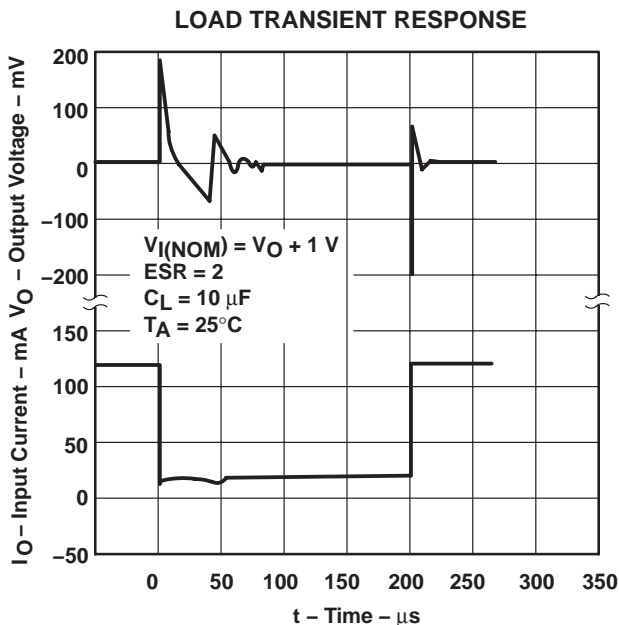

Figure 11

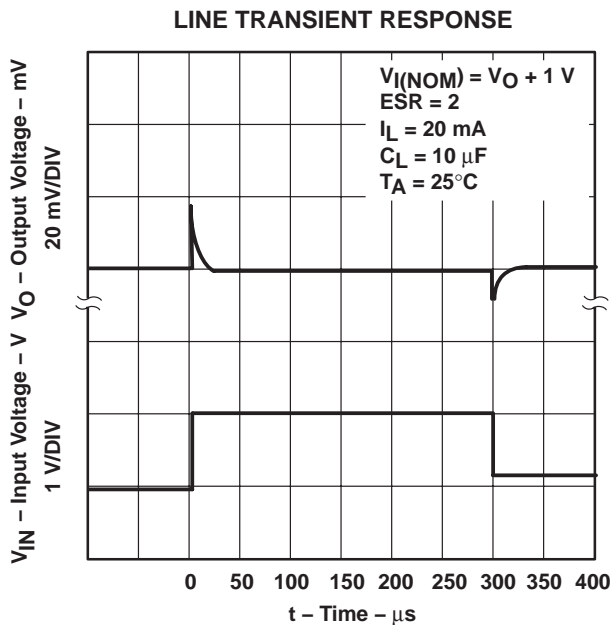

Figure 12

IMPORTANT NOTICE

Texas Instruments Incorporated and its subsidiaries (TI) reserve the right to make corrections, modifications, enhancements, improvements, and other changes to its products and services at any time and to discontinue any product or service without notice. Customers should obtain the latest relevant information before placing orders and should verify that such information is current and complete. All products are sold subject to TI's terms and conditions of sale supplied at the time of order acknowledgment.

TI warrants performance of its hardware products to the specifications applicable at the time of sale in accordance with TI's standard warranty. Testing and other quality control techniques are used to the extent TI deems necessary to support this warranty. Except where mandated by government requirements, testing of all parameters of each product is not necessarily performed.

TI assumes no liability for applications assistance or customer product design. Customers are responsible for their products and applications using TI components. To minimize the risks associated with customer products and applications, customers should provide adequate design and operating safeguards.

TI does not warrant or represent that any license, either express or implied, is granted under any TI patent right, copyright, mask work right, or other TI intellectual property right relating to any combination, machine, or process in which TI products or services are used. Information published by TI regarding third-party products or services does not constitute a license from TI to use such products or services or a warranty or endorsement thereof. Use of such information may require a license from a third party under the patents or other intellectual property of the third party, or a license from TI under the patents or other intellectual property of TI.

Reproduction of TI information in TI data books or data sheets is permissible only if reproduction is without alteration and is accompanied by all associated warranties, conditions, limitations, and notices. Reproduction of this information with alteration is an unfair and deceptive business practice. TI is not responsible or liable for such altered documentation. Information of third parties may be subject to additional restrictions.

Resale of TI products or services with statements different from or beyond the parameters stated by TI for that product or service voids all express and any implied warranties for the associated TI product or service and is an unfair and deceptive business practice. TI is not responsible or liable for any such statements.

TI products are not authorized for use in safety-critical applications (such as life support) where a failure of the TI product would reasonably be expected to cause severe personal injury or death, unless officers of the parties have executed an agreement specifically governing such use. Buyers represent that they have all necessary expertise in the safety and regulatory ramifications of their applications, and acknowledge and agree that they are solely responsible for all legal, regulatory and safety-related requirements concerning their products and any use of TI products in such safety-critical applications, notwithstanding any applications-related information or support that may be provided by TI. Further, Buyers must fully indemnify TI and its representatives against any damages arising out of the use of TI products in such safety-critical applications.

TI products are neither designed nor intended for use in military/aerospace applications or environments unless the TI products are specifically designated by TI as military-grade or "enhanced plastic." Only products designated by TI as military-grade meet military specifications. Buyers acknowledge and agree that any such use of TI products which TI has not designated as military-grade is solely at the Buyer's risk, and that they are solely responsible for compliance with all legal and regulatory requirements in connection with such use.

TI products are neither designed nor intended for use in automotive applications or environments unless the specific TI products are designated by TI as compliant with ISO/TS 16949 requirements. Buyers acknowledge and agree that, if they use any non-designated products in automotive applications, TI will not be responsible for any failure to meet such requirements.

Following are URLs where you can obtain information on other Texas Instruments products and application solutions:

Products

Amplifiers	amplifier.ti.com
Data Converters	dataconverter.ti.com
DSP	dsp.ti.com
Clocks and Timers	www.ti.com/clocks
Interface	interface.ti.com
Logic	logic.ti.com
Power Mgmt	power.ti.com
Microcontrollers	microcontroller.ti.com
RFID	www.ti-rfid.com
RF/IF and ZigBee® Solutions	www.ti.com/lprf

Applications

Audio	www.ti.com/audio
Automotive	www.ti.com/automotive
Broadband	www.ti.com/broadband
Digital Control	www.ti.com/digitalcontrol
Medical	www.ti.com/medical
Military	www.ti.com/military
Optical Networking	www.ti.com/opticalnetwork
Security	www.ti.com/security
Telephony	www.ti.com/telephony
Video & Imaging	www.ti.com/video
Wireless	www.ti.com/wireless

Mailing Address: Texas Instruments, Post Office Box 655303, Dallas, Texas 75265
Copyright © 2008, Texas Instruments Incorporated