

COLOR TV PAL DECODER

- PHASE LOCKED REFERENCE OSCILLATOR
- U AND V AXIS DECODERS
- ACC AND IDENTIFICATION DETECTORS
- KILLER
- USE OF A STANDARD 4.43 MHz Xtal
- COMPATIBILITY WITH THE SECAM DECODER TEA5630 FOR PAL-SECAM APPLICATION

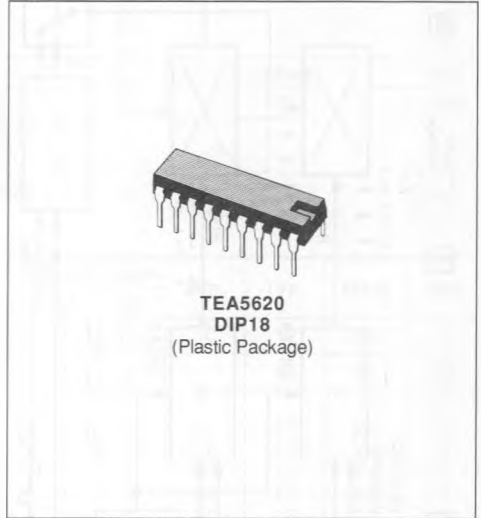

DESCRIPTION

The TEA5620 is a color TV PAL decoder. It combines all functions required for the identification and demodulation of PAL signal.

PIN CONNECTIONS

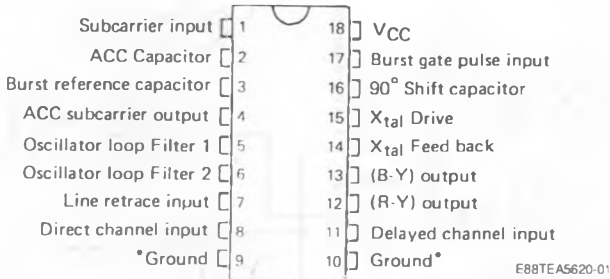

* Pins 9 and 10 have to be both grounded.

BLOCK DIAGRAM

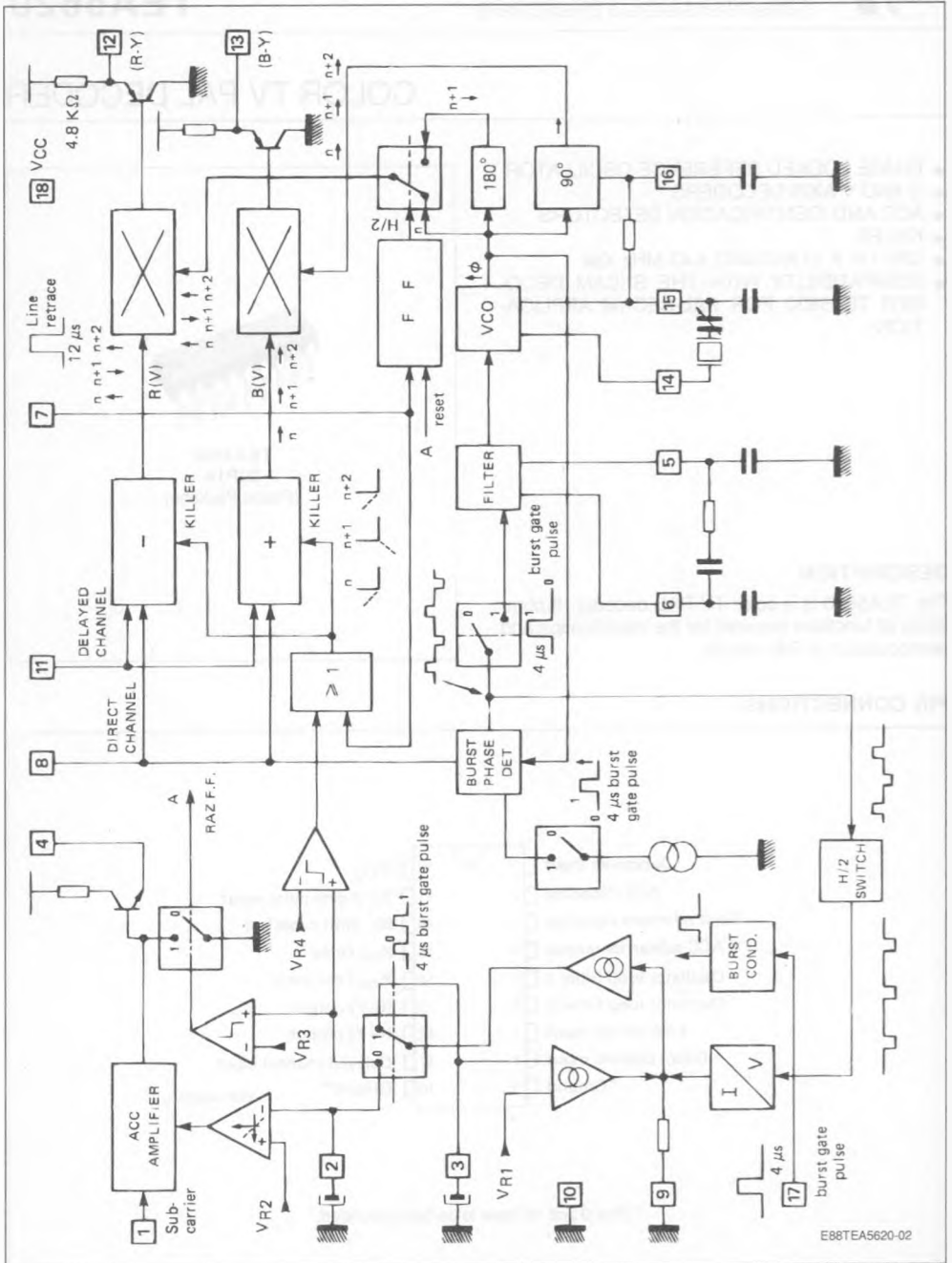

E88TEA5620-02

ABSOLUTE MAXIMUM RATINGS

Symbol	Parameter	Value	Unit
V_{CC}	Supply Voltage	14.4	V
P_D	Power Dissipation	800	mW
T_{amb}	Operating Ambient Temperature	0 to 70	°C
T_{stg}	Storage Temperature	- 55 to 150	°C

THERMAL DATA

Symbol	Parameter	Value	Unit
$R_{th(j-a)}$	Junction-ambient Thermal Resistance	70	°C/W

DC ELECTRICAL CHARACTERISTICS

$T_{amb} = + 25\text{ °C}$ $V_{CC} = 12\text{ V}$ (unless otherwise specified)

(see test circuit 1)

Parameter		Switch State		Min.	Typ.	Max.	Unit
		S1	S2				
Operating Supply Voltage	Pin 18	1	1	10	12	14.4	V
Supply Current	Pin 18	1	1		40	52	mA
DC Voltage at :							
	Pin 1	1	1	5.1	5.7	6.3	V
	Pin 4	0	1	7.6	8.5	9.4	V
	Pin 5	1	2	6.2	7.7	9.2	V
	Pin 6	1	2	6.2	7.7	9.2	V
	Pin 8 - Pin 11	1	1	2.2	2.5	2.8	V
	Pin 12 - Pin 13	1	1	9.5	10.3	11.1	V
	Pin 14	1	2	8.7	9.5	10.7	V
	Pin 15 - Pin 16	1	1	2.7	3.3	3.9	V
DC Voltage, with Sample Pulse to Pin 17, at :							
	Pin 2 - Pin 3	0	3	4.3	4.7	5.3	V

AC ELECTRICAL CHARACTERISTICS

T_{amb} = + 25 °C V_{CC} = 12 V (unless otherwise specified)

(see test circuit 2)

Symbol	Parameter		Min.	Typ.	Max.	Unit
BoV	ACC Amplifier Output Voltage (burst input : 0.1 Vpp)	Pin 4	0.45	0.6	0.76	Vpp
ΔBoV ₁	ACC Amplifier Output Voltage Variation (burst input : + 6 dB = 0.2 Vpp)	Pin 4	- 1	0	+ 1	dB
ΔBoV ₂	ACC Amplifier Output Voltage Variation (burst input : - 20 dB = 10 mVpp)	Pin 4	- 5	- 2	+ 1	dB
ED1 _{RY}	R-Y Output Voltage (colour bar input signal : 0.1 Vpp)	Pin 12	0.7	1.4	1.95	Vpp
ED1 _{BY}	B-Y Output Voltage (colour bar input signal : 0.1 Vpp)	Pin 13	0.9	1.5	1.95	Vpp
$\frac{ED1_{BY}}{ED1_{RY}}$	Output Voltage Ratio : B-Y/R-Y		0.9	1.05	1.15	
Δ ED1 _{RY}	R-Y Output Voltage Variation (V _{CC} : 12 V to 14.4 V or V _{CC} : 12 V to 9.6 V)	Pin 12	0.15		0.55	Vpp
Δ ED1 _{BY}	B-Y Output Voltage Variation (V _{CC} : 12 V to 14.4 V or V _{CC} : 12 V to 9.6 V)	Pin 13	0.15		0.55	Vpp
EL	HF Residual Voltage (colour bar input signal : 0.1 Vpp)	Pins 12 - 13		100	120	mVpp
EK	Colour Killer Level (reference input signal : 0.1 Vpp)		- 40	- 35	- 30	dB
ELK	Colour Killer Leakage (colour killer on)	Pins 12 - 13			20	mVpp
V _{CC}	Minimum Supply Voltage for Internal Oscillator Operation			6	8	V
Ri ₁	Input Impedance (input signal : F = 4.43 MHz)	Pin 1		2.8		kΩ
Cl ₁	(V _i = 100 mVpp)			10		pF
To	Delay time between line retrace pulse and first colour response	Pin 12	0.4	1.3	2	μs
	VCO Control Sensitivity : Variation of Frequency Oscillator Versus Pin 5 to Pin 6 Difference Voltage (burst input 0.7 Vpp on pin 8)			1.8		Hz/mV
Fp	Pull-in Frequency Range (variation of burst frequency)	Pin 15		± 800		Hz
∅	Phase Hold Characteristics (phase deviation for ΔF burst = 100 Hz)			0.03		°/Hz
V _{dir}	Line retrace threshold	Pin 7		2.5		V
V _{d1}	Sampling Pulse Threshold	Pin 17	0	.6	0.8	1

Test Circuit 1.

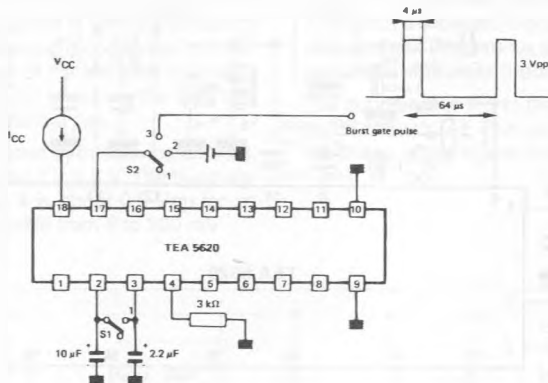

E88TEA5620-03

Test Circuit 2.

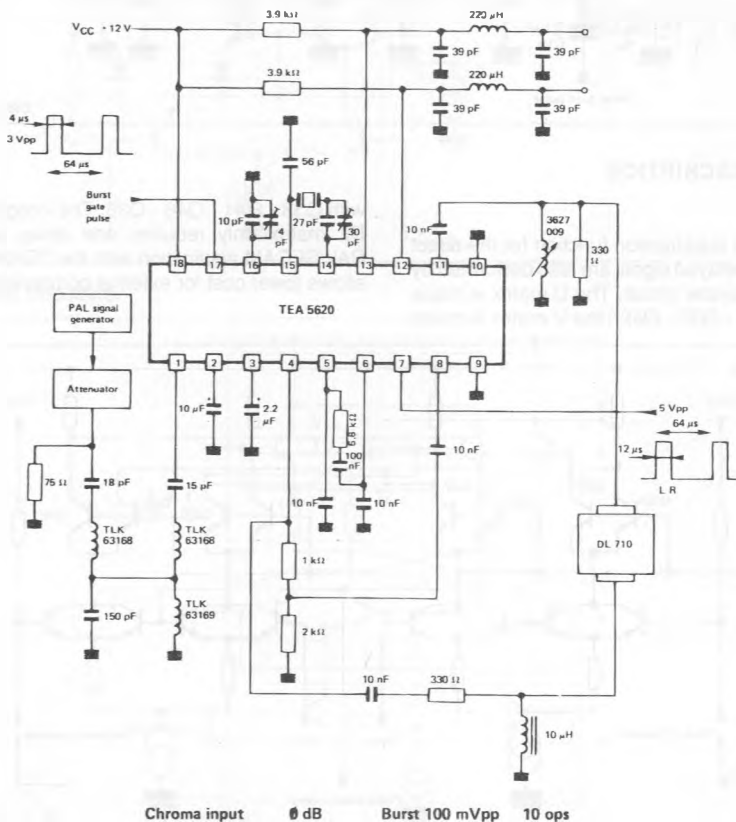

E88TEA5620-04

TYPICAL PAL APPLICATION

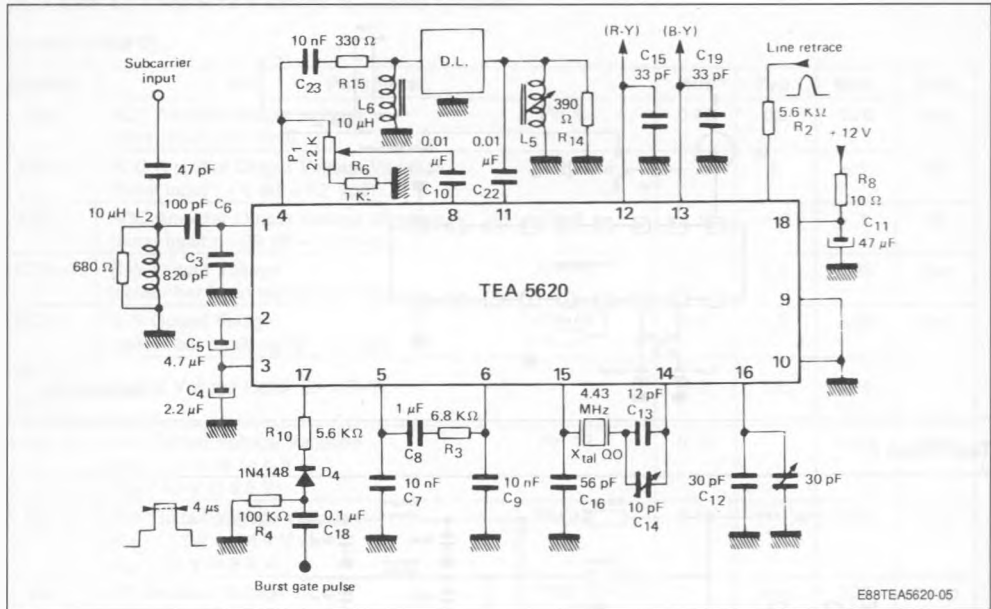

GENERAL DESCRIPTION

DL MATRIX

The adding and subtraction function for the direct signal and the delayed signal are also performed by the IC with the under circuit. The U matrix is made with Q32 - Q45 - Q37 - Q42 ; the V matrix is made

with Q33 - Q41 - Q46 - Q36. The integration of the DL matrix only requires one delay line for the PAL/SECAM application with the TEA5630. It also allows lower cost for external components.

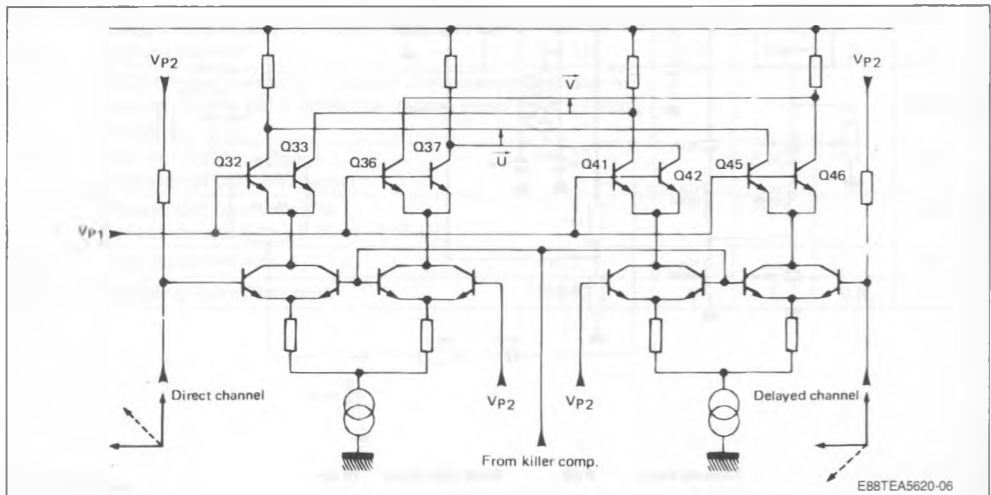

ACC AMPLIFIER

This ACC amplifier is performed with a double differential stage. The subcarrier is sent to the input of the first pair, while the second is connected to a reference voltage. The gain of the amplifier is controlled by the ACC voltage, by switching the bias current through a third differential pair.

The dynamic range obtained by this device is 32 dB. The bias voltage on the pin 1 is 5.6 V. The burst signal delivered by the pin 4 is about 0.6 V_{pp} for an input signal on pin 1 variable from 5 to 200 mV.

ACC amplifier.

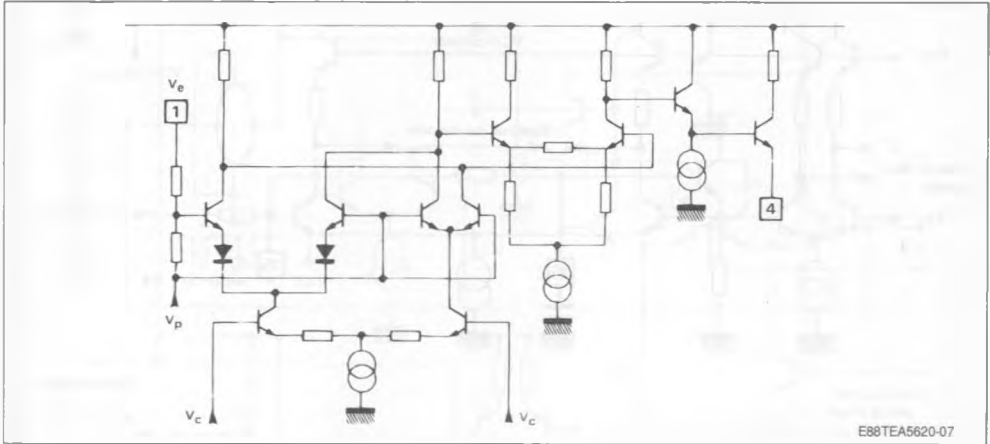

U and V Axis Decoders.

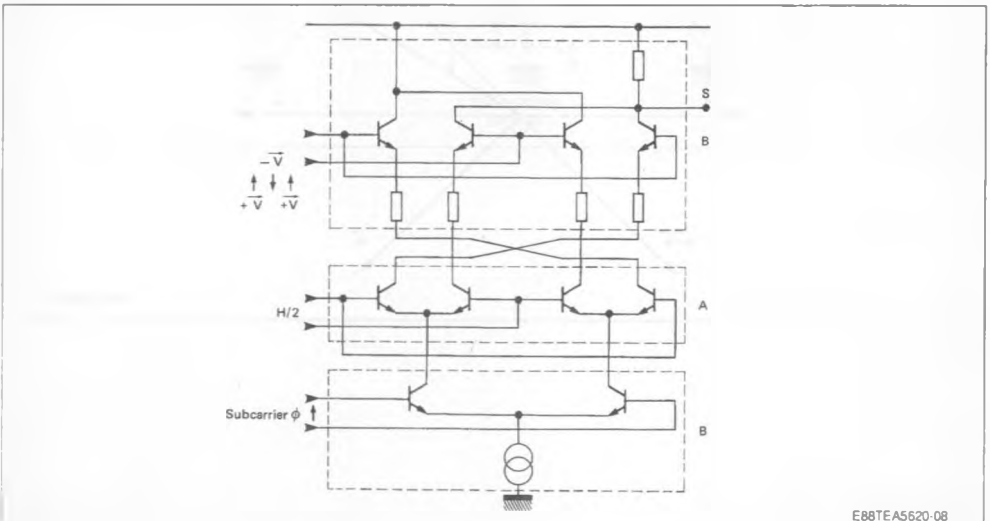

VOLTAGE CONTROL OSCILLATOR

The frequency of the VCO is depending on the vector adding performed at point A between \vec{b} and \vec{d} (see graphe). This adding is controlled by the voltage coming from the burst phase detector. This

VCO is attractive because it uses a standard low cost Xtal. The 90° phase shift is made by vector addition and by a 45° phase shifter connected to the pin 16.

Voltage Control Oscillator.

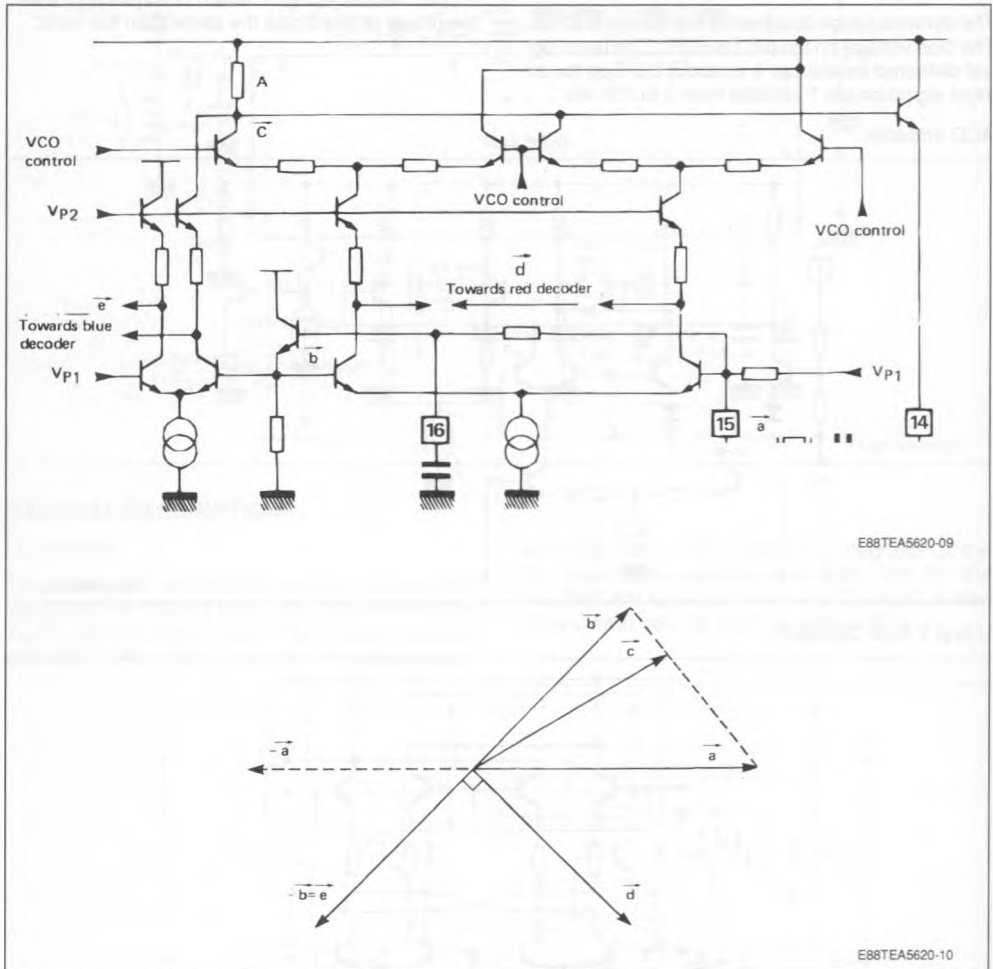

SAMPLING AND HOLD STAGE

This stage performs the identification and provides the ACC control voltage. A bias voltage is stored in C_2 capacitor during the line trace. The C_1 capacitor stores this bias voltage decreased by the demodu-

lated burst peak value. So the differential voltage between C_1 and C_2 is not depending of a bias voltage, out of any drift, and therefore suitable to control the ACC amplifier.

Sampling and Hold Stage.

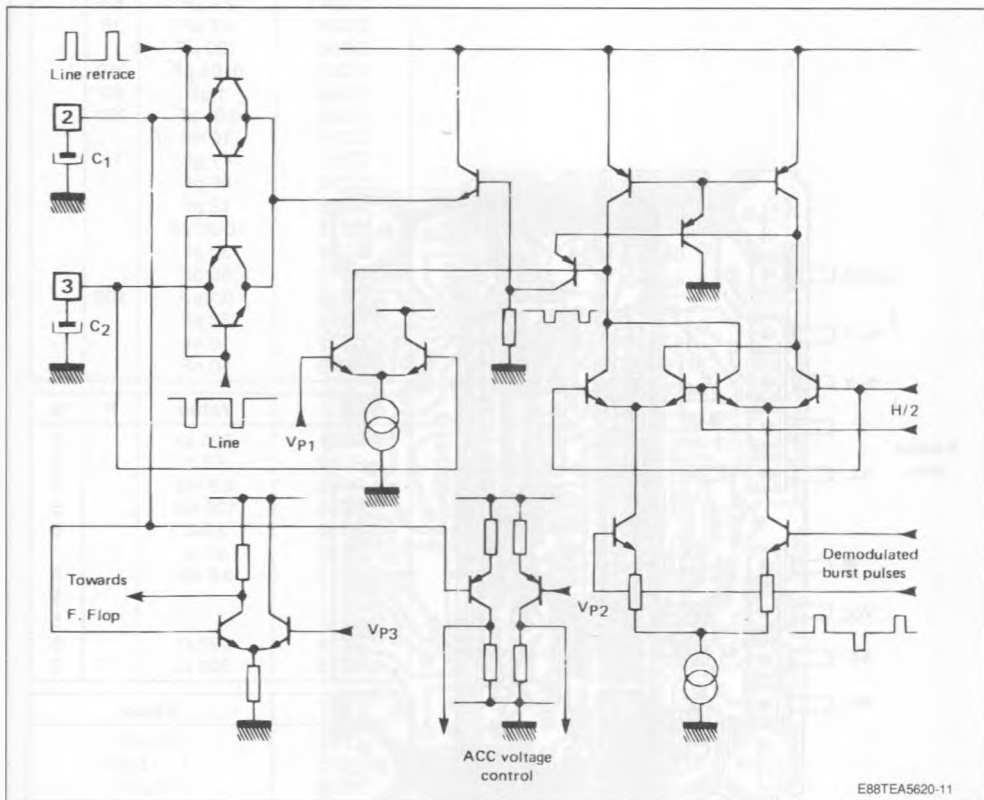

TYPICAL APPLICATION (see electric diagram page 6)

Component Side.

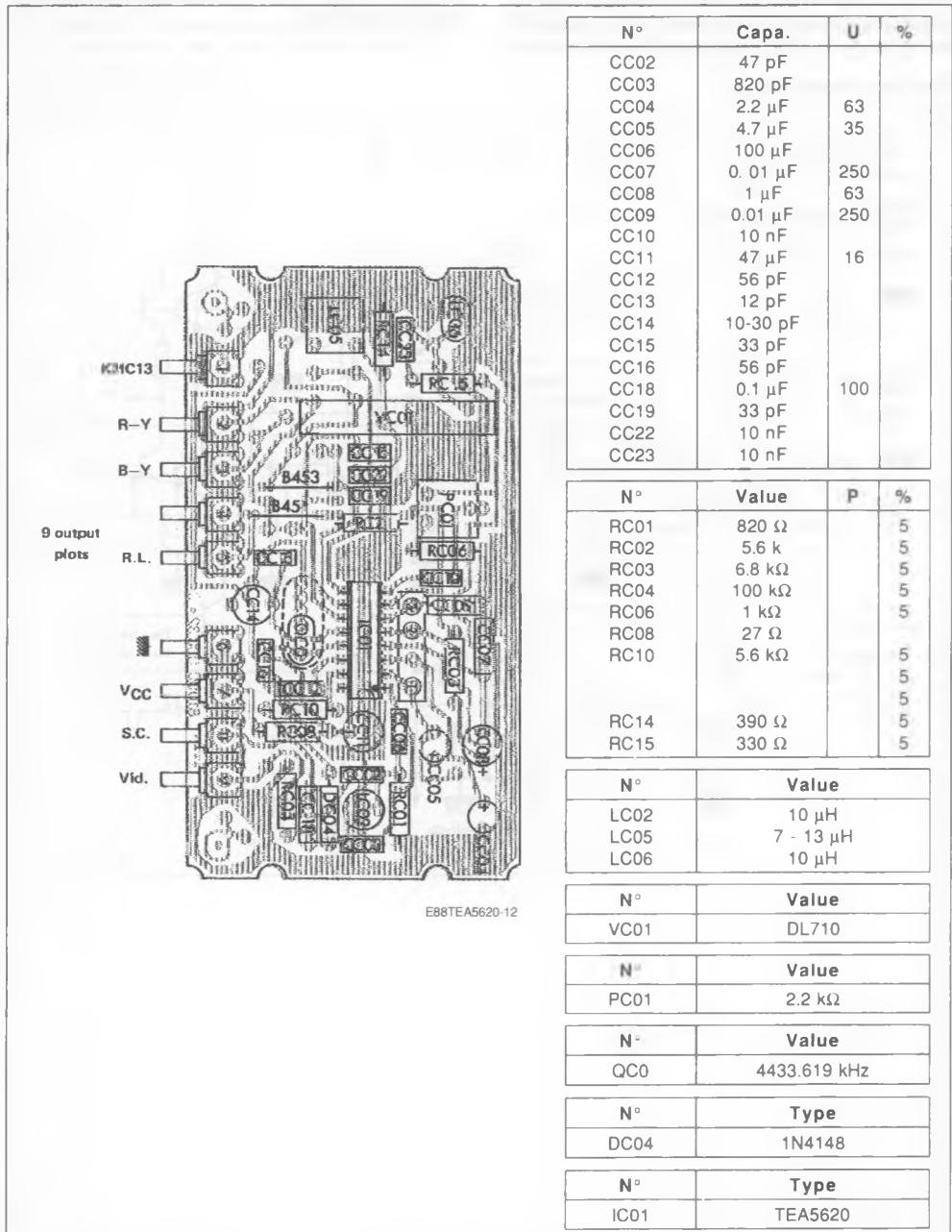

E88TEA5620-12

N°	Capa.	U	%
CC02	47 pF		
CC03	820 pF		
CC04	2.2 μ F	63	
CC05	4.7 μ F	35	
CC06	100 μ F		
CC07	0.01 μ F	250	
CC08	1 μ F	63	
CC09	0.01 μ F	250	
CC10	10 nF		
CC11	47 μ F	16	
CC12	56 pF		
CC13	12 pF		
CC14	10-30 pF		
CC15	33 pF		
CC16	56 pF		
CC18	0.1 μ F	100	
CC19	33 pF		
CC22	10 nF		
CC23	10 nF		

N°	Value	P	%
RC01	820 Ω		5
RC02	5.6 k		5
RC03	6.8 k Ω		5
RC04	100 k Ω		5
RC06	1 k Ω		5
RC08	27 Ω		5
RC10	5.6 k Ω		5
RC14	390 Ω		5
RC15	330 Ω		5

N°	Value
LC02	10 μ H
LC05	7 - 13 μ H
LC06	10 μ H

N°	Value
VC01	DL710

N°	Value
PC01	2.2 k Ω

N°	Value
QC0	4433.619 kHz

N°	Type
DC04	1N4148

N°	Type
IC01	TEA5620

Copper Side.

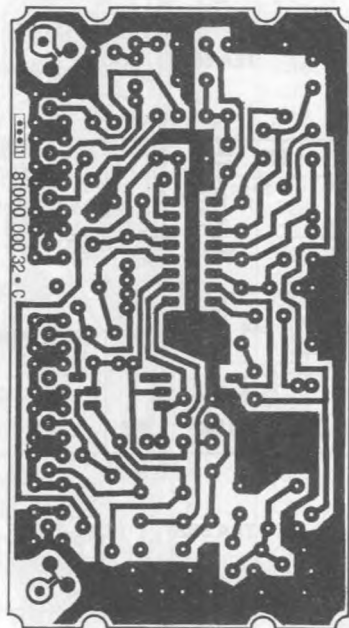

E88TEA5620-13

PAL SECAM APPLICATION TEA5620-TEA5630

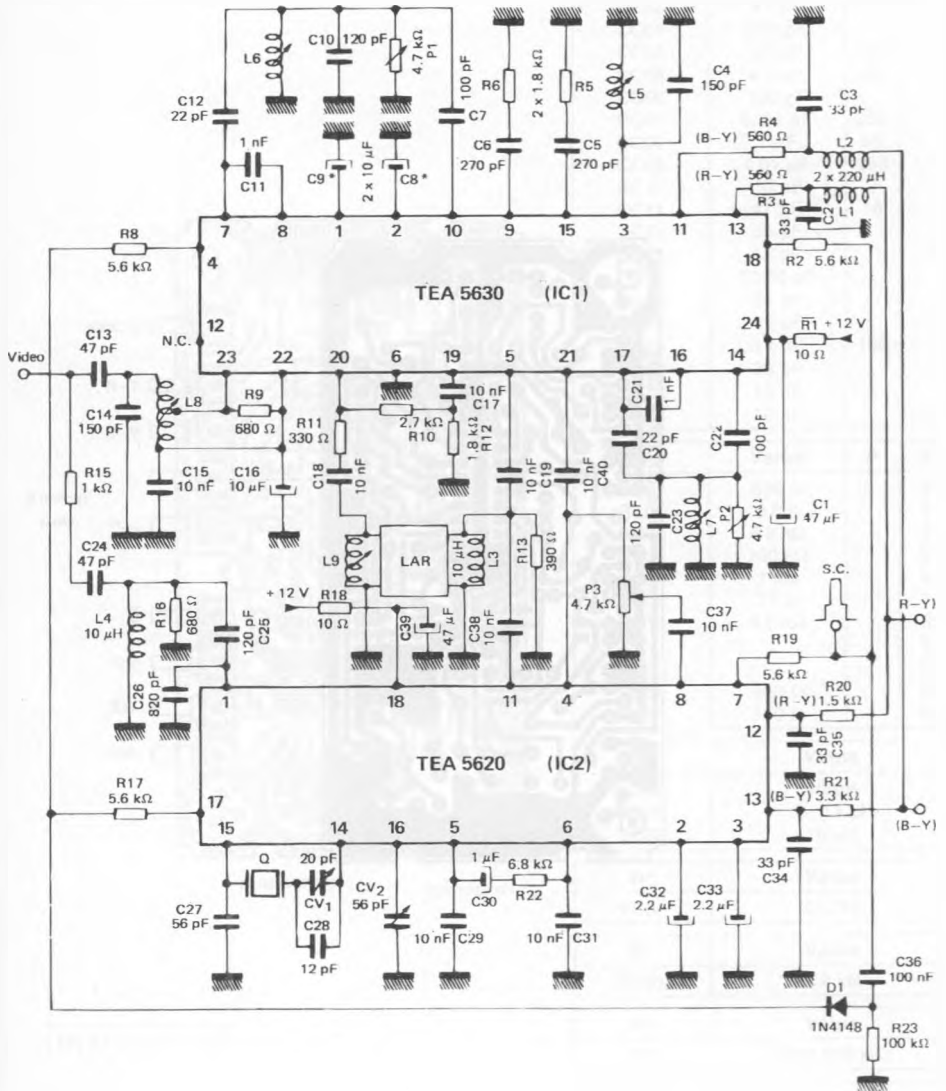

E88TEA5620-14

Component Side.

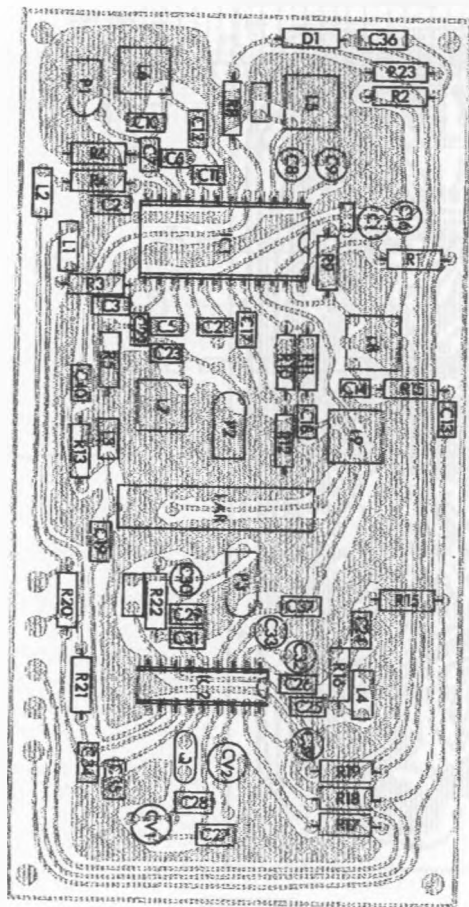

E88TEA5620-15

N°	Value
C1	47 μ F
C2	33 pF
C3	33 pF
C4	150 pF
C5	270 pF
C6	270 pF
C7	100 pF
C8-C9	10 μ F/16 V
C10	120 pF
C11	1 nF
C12	22 pF
C13	47 pF
C14	150 pF
C15	10 nF
C16	10 μ F/16 V
C17	10 nF
C18	10 nF
C19	10 nF
C20	22 pF
C21	1 nF
C22	100 pF
C23	120 pF
C24	47 pF
C25	120 pF
C26	820 pF
C27	56 pF
C28	12 pF
C29	10 nF
C30	1 μ F/16 V
C31	10 nF
C32	22 μ F/16 V
C33	22 μ F/16 V
C34	33 pF
C35	33 pF
C36	100 nF
C37	10 nF
C38	10 nF
C39	47 μ F/25 V
C40	10 nF

N°	Value
R1	10 Ω
R2	5.6 k Ω
R3	560 Ω
R4	560 Ω
R5	1.8 k Ω
R6	1.8 k Ω
R8	5.6 k Ω
R9	680 Ω
R10	2.7 k Ω
R11	330 Ω
R12	1.8 k Ω
R13	390 Ω
R15	1 k Ω
R16	680 Ω
R17	5.6
R18	k Ω
R19	10 Ω
R20	5.6 k Ω
R21	1.5 k Ω
R22	3.3 k Ω
R23	6.8 k Ω

N°	Value
P1	4.7 k Ω
P2	4.7 k Ω
P3	4.7 k Ω
Q Quartz	4.433 MHz
CV ₁	3-30 pF
CV ₂	6-60 pF

N°	Type or Value
D1	1N4148
LAR	LAA64 μ s
IC ₁	TEA5630
IC ₂	TEA5620
L1	220 μ H
L2	220 μ H
L3	10 μ H
L4	10 μ H
L8	0.7-1.3 μ H

N°	Type	Value
L5	TOKO RCL 36270-14	10-15 μ H
L6	TOKO RCL 36270-13	7 μ H
L7	TOKO RCL 36270-13	7 μ H
L8	TOKO RCL 36270-09	10 μ H

Copper Side.

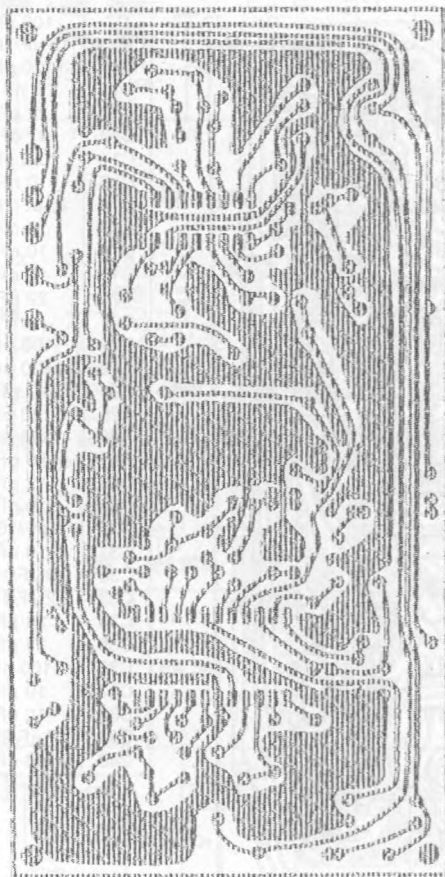

E88TEA5620-16

PACKAGE MECHANICAL DATA

18 PINS – PLASTIC DIP

