

HORIZONTAL AND VERTICAL DEFLECTION MONITOR

- DIRECT FRAME YOKE DRIVE $\pm 1.5A$ DRIVING CURRENT
- LINE DARLINGTON DRIVING CAPABILITY
- BUILT-IN FRAME SEPARATOR WITHOUT EXTERNAL COMPONENTS
- MUTING OUTPUT
- INTEGRATED FLYBACK GENERATOR
- FRAME OUTPUT PROTECTION AGAINST SHORT CIRCUITS
- VERY FEW EXTERNAL COMPONENTS
- HIGH DISSIPATION POWER PACKAGE

DESCRIPTION

The TEA2017 is an horizontal and vertical deflection circuit. It is particularly intended for black and white TV and display video units but it can also be used in low cost color TV applications. The TEA2017 provides a low cost deflection system.

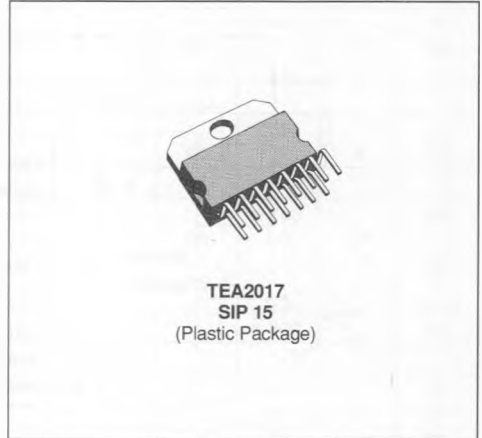

PIN CONNECTIONS

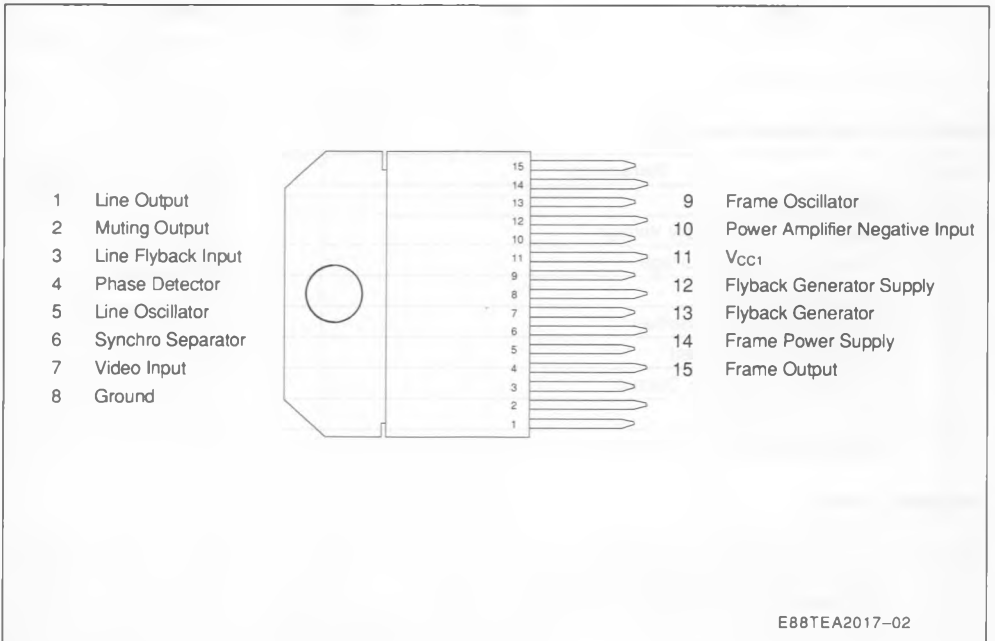

BLOCK DIAGRAM

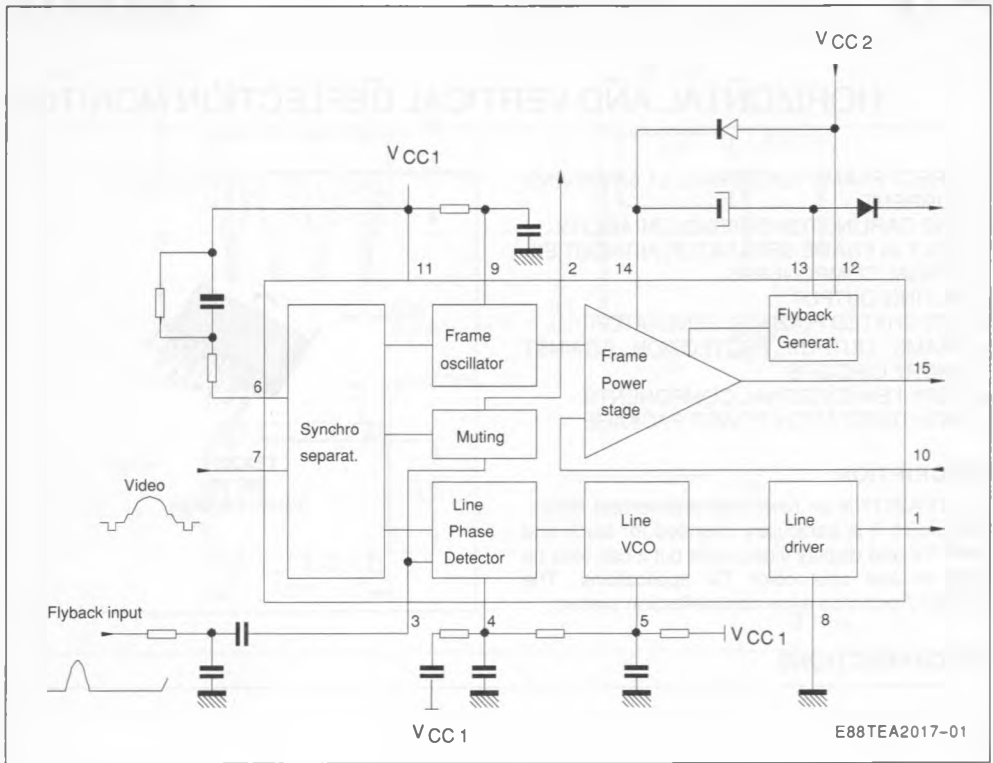

ABSOLUTE MAXIMUM RATINGS

Symbol	Parameter	Value	Unit
VCC1	Supply Voltage	20	V
V12	Flyback Generator Supply Voltage	30	V
V14	Frame Power Supply Voltage	60	V
I15	Frame Output Current	± 1.5	A
V1	Line Output Voltage (external)	60	V
I _{p1}	Line Output Peak Current	0.8	A
I _{c1}	Line Output Continuous Current	0.4	A
T _{stg}	Storage Temperature	- 40 to 150	°C
T _j	Max Operating Junction Temperature	150	°C

THERMAL DATA

R _{th (j-c)}	Max Junction-case Thermal Resistance	3	°C/W
R _{th (j-a)}	Typical Junction-ambient Thermal Resis.	40	°C/W
T _J	Max Recommended Junction Temperature	120	°C

ELECTRICAL CHARACTERISTICS

(Tamb = 25°C ; VCC1 = 10V)

Symbol	Parameter	Min.	Typ.	Max.	Unit
	Supply Pin 11				
ICC1	Supply Current		15		mA
VCC1	Supply Voltage	8		20	V
	Video Input Pin 7				
V7	Input Threshold Voltage (I7 = - 1μA) Video Input Signal (see figure application n°1)	0.4	4	4	V Vpp
	Line Flyback Input Pin 3				
V3	Bias Voltage		2.7		V
Z3	Input Impedance	4.5	6	8	KΩ
	Phase Comparator Pin 4				
I4	Output Current During Synchro Pulse		± 600		μA
I4R	Current Ratio (positive/negative)	0.9	1.0	1.1	
LI4	Leakage Current	- 1		+ 1	μA
	Control Range Voltage	2.5		7	V
	Control Sensibility (see figure application n°1)		750		Hz/μs
	Pull in Range (see figure application n°1)		± 800		Hz
	Line Oscillator Pin 5				
LT5	Low Threshold Voltage		3.2		V
HT5	High Threshold Voltage		6.6		V
BI5	Bias Current		50		nA
DR5	Discharge Impedance		800		Ω
FLP1	Free Running Line Period R = 12KΩ Tied to VCC1 C = 6.8nF Tied to Ground	61.5	64	66.5	μs
FLP2	Free Running Line Period R = 12.3KΩ C = 2.2nF		27		μs
OT5	Oscillator Threshold for Line Output Pulse Triggering		5		V
$\frac{\Delta T}{\Delta V}$	Supply Voltage Influence on Free-running Period		0.051		μs/V

ELECTRICAL CHARACTERISTICS

(Tamb = 25°C ; VCC1 = 10V ; V14 = 30V)

Symbol	Parameter	Min.	Typ.	Max.	Unit
	Line Output Pin 1				
LV1 CPW	Saturation Voltage to Ground (I1 = 200mA) Output Pulse Width (line period = 64µs)	20	1.1 22	1.5 24	V µs
	Muting Pin 2				
	(see figure application n°1) Output Voltage : Without Video Signal With Video Signal		8 0.7	1.2	V V
	Frame Oscillator Pin 9				
LT9	Low Threshold Voltage	1.8	2	2.3	V
HT9	High Threshold Voltage	2.6	3.1	3.6	V
BI9	Bias Current		100		nA
DR9	Discharge Impedance		500		Ω
FFP1	Free Running Frame Period R = 845KΩ Tied to VCC1 C = 180nF Tied to Ground	21.4	22.5	25	ms
FFP2	Free Running Frame Period R = 425KΩ C = 220nF		14.3		ms
MFP	Minimum Frame Period	14.6	17	19	ms
FG	(I7 = - 100µA) with the Same RC Frame Sawtooth Gain between Pin 9 and non-inverting Input of the Frame Amplifier (internal)		- 0.4		
	Frame Power Supply Pin 14				
V14 I14	Operating Voltage (with flyback generator) Supply Current (V14 = 30V)	10	16	58 25	V mA
	Flyback Generator Supply Pin 12				
V12	Operating Voltage	10		30	V
	Frame Output				
LV15A LV15B	Saturation Voltage to Ground I15 = 0.1A I15 = 1A		60 0.4	0.8	mV V
HV15A HV15B	Saturation Voltage to VCC2 I15 = - 0.1A I15 = - 1A		1.3 1.7	2.4	V V
FV15A FV15B	Saturation Voltage to VCC2 in Flyback Mode (V15 > V14) I15 = 0.1A I15 = 1A		1.7 2.6	4	V V
	Flyback Generator Pin 12 And 13				
F2DA F2DB FSVA FSVB	* Flyback Transistor on (output = high state) V3/2 With I3 → 2 = 0.1A I3 → 2 = 1A V2/3 With I2 → 3 = 0.1A I2 → 3 = 1A		1.6 3 0.9 2	4	V V V V
FCI	* Flyback Transistor off (output = V14 - 8V) V12 = V14 = 30V Leakage Current Pin 12			100	µA

GENERAL DESCRIPTION

The TEA2017 performs all of the video and power functions required to provide signals for the direct drive of a line darlington and the frame yoke.

It contains :

- A synchronizing separator with the slice level of synchro separation determined by the external components.
- An integrated frame synchronizing separator without external components.

- A saw tooth generator for the frame with synchronization allowed during the last fourth of the free run period.
- A power amplifier for direct drive of the frame yoke with overload, short circuit and thermal protections.
- A line phase detector and a voltage control oscillator.
- An open collector output for the direct drive of a line darlington.
- A muting output.

SYNCHRONIZATION SEPARATOR CIRCUIT

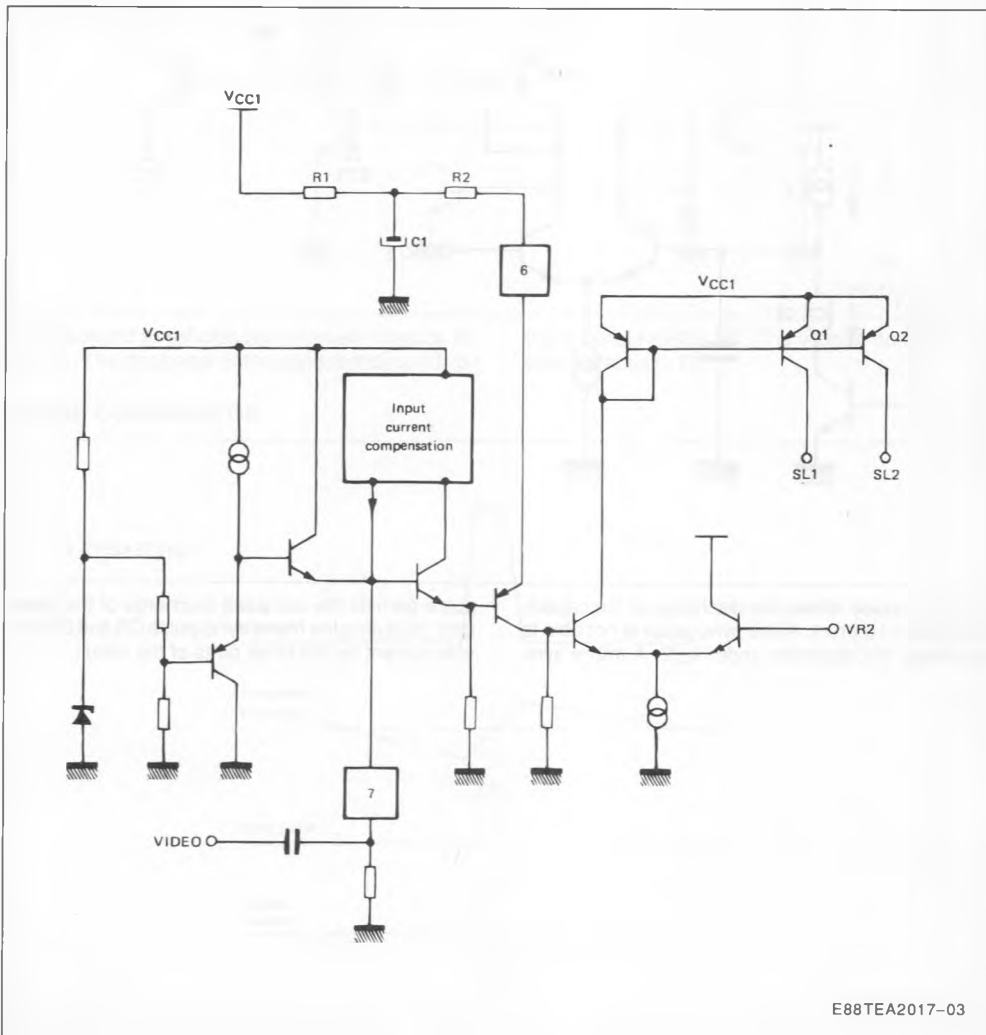

The sync-tip DC level on pin 7 is clamped to 3.8V. The slice level of sync-separation present on capacitor C1 depends on the value of resistor R1 and R2.

When the video signal on pin 7 decreases under the capacitor voltage the transistors Q1 and Q2 provide current for the other parts of the circuit.

FRAME SEPARATOR

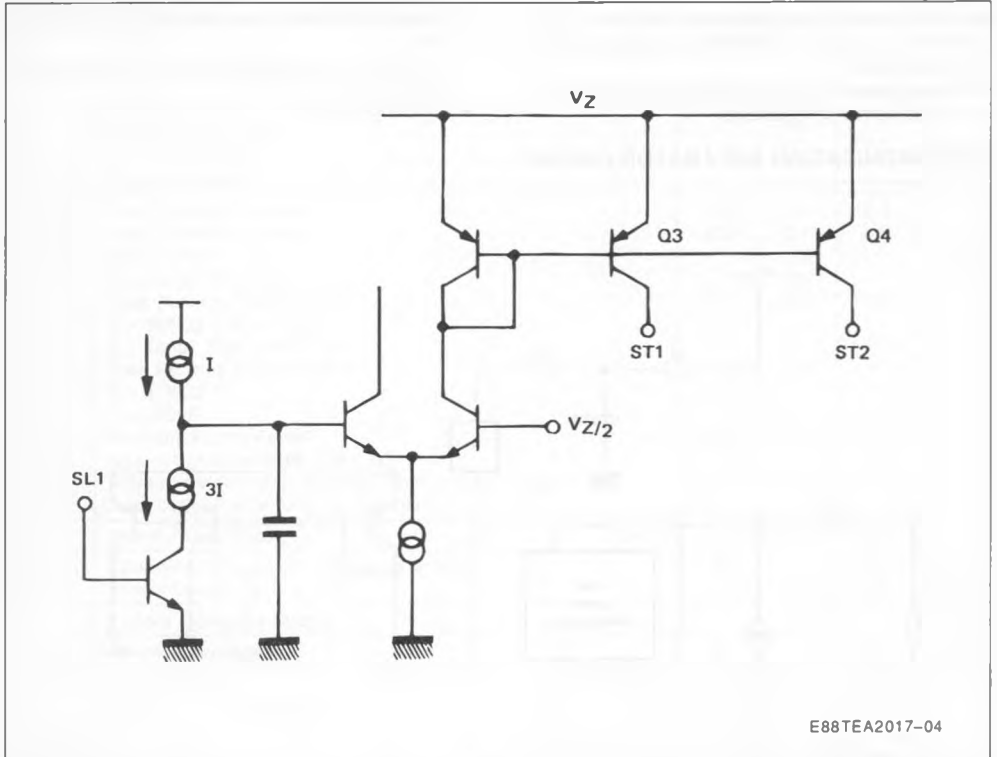

E88TEA2017-04

The sync-pulse allows the discharge of the capacitor by a $2 \times I$ current. A line sync-pulse is not able to discharge the capacitor under $V_Z/2$. A frame sync

pulse permits the complete discharge of the capacitor, so during the frame sync-pulse Q3 and Q4 provide current for the other parts of the circuit.

LINE OSCILLATOR

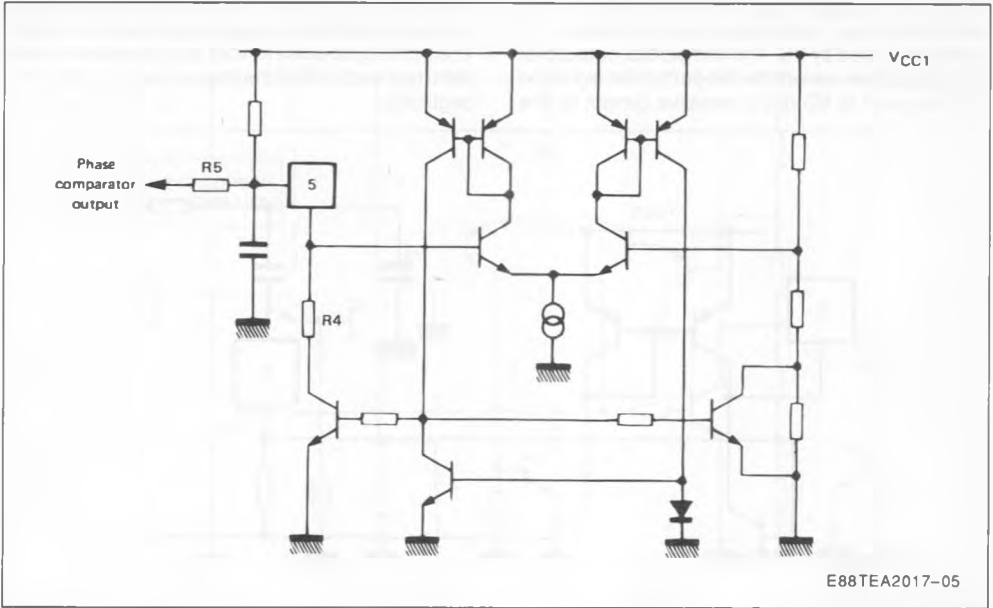

The oscillator thresholds are internally fixed by resistors. The discharge of the capacitor depends on

the internal resistor R4. The voltage control is applied on resistor R5.

PHASE COMPARATOR

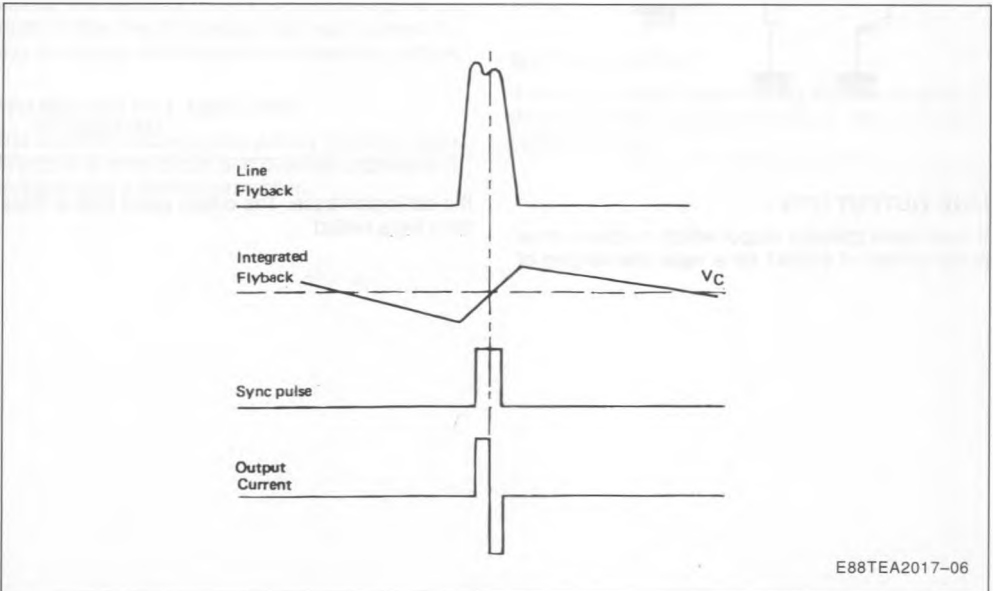

The sync-pulse drives the current in the comparator. The line flyback integrated by the external network gives on pin 3 a saw tooth, the DC offset of this saw tooth is fixed by VC. The comparator output provides a positive current for the part of the signal on pin 3 superior to VC and a negative current for the

other part. When the line flyback and the video signal are synchronized, the output of the comparator is an alternately negative and positive current. The frame sync-pulse inhibits the comparator to prevent frequency drift of the line oscillator on the frame beginning.

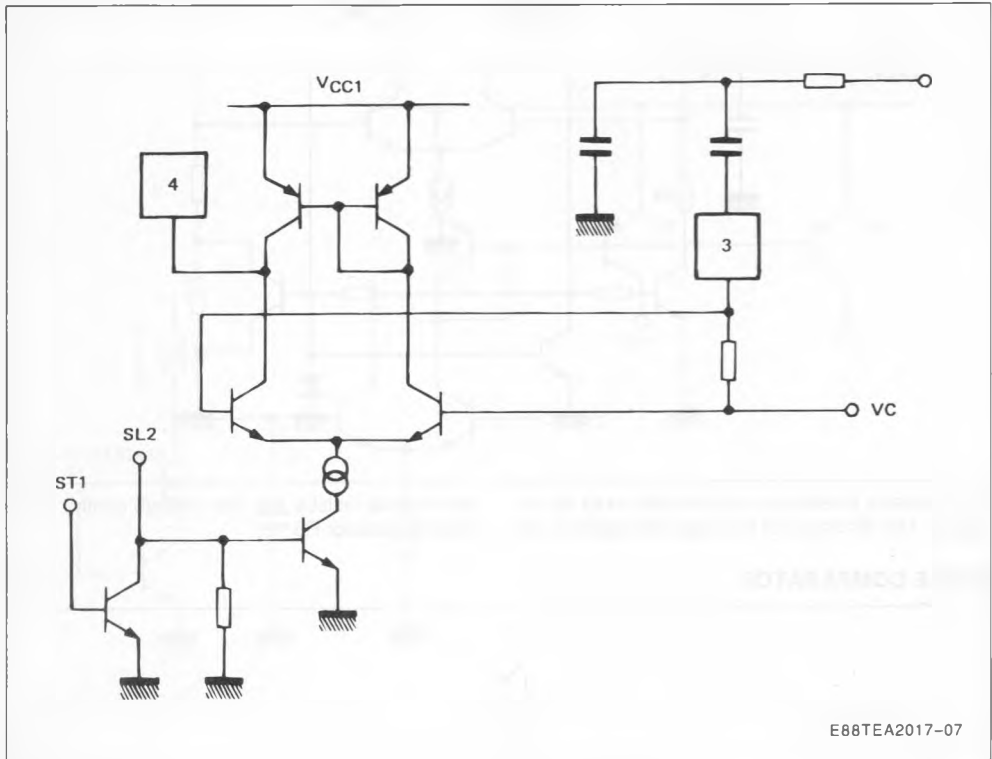

LINE OUTPUT (PIN 1)

It is an open collector output which is able to drive pulse current of 500mA for a rapid discharging of

the darlington base. The output pulse time is $22\mu\text{s}$ for a $64\mu\text{s}$ period.

FRAME OSCILLATOR

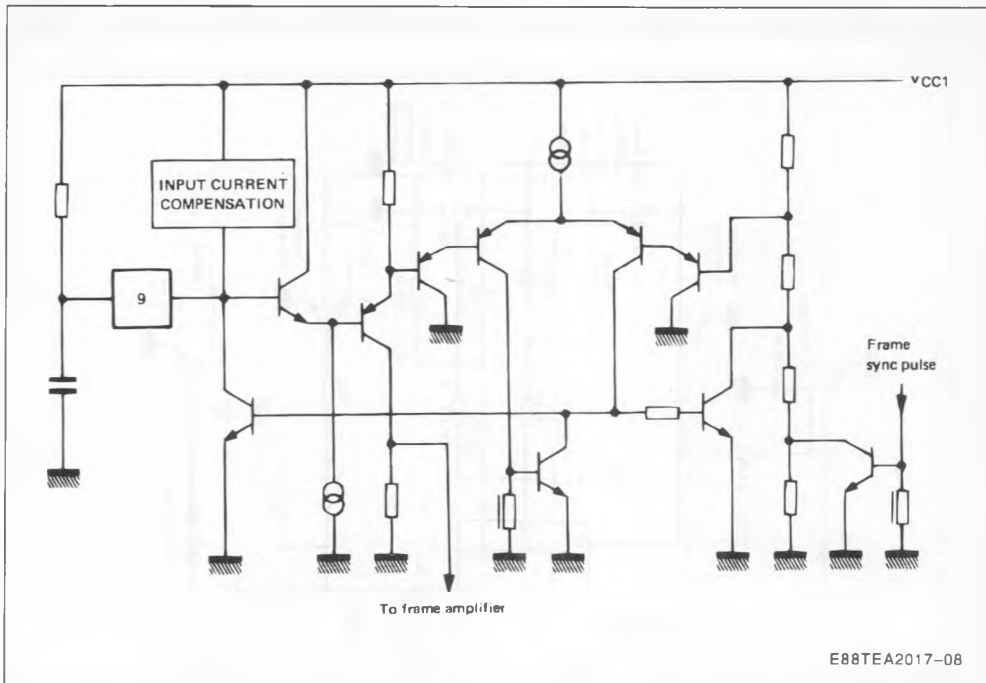

E88TEA2017-08

The oscillator thresholds are internally fixed by resistors. The oscillator is synchronized during the last fourth of the free run period. The input current during the charge of the capacitor is less than 100nA.

FRAME OUTPUT AMPLIFIER

This amplifier is able to drive directly the frame yoke. Its output is short circuit and overload protected ; it contains also a thermal protection.

Its positive input is directly connected to the invert of the frame saw tooth.

MUTING OUTPUT

It delivers voltage pulse during the line fly-back if there is no video signal on the input. The output impedance is 1k Ω .

APPLICATION N°1 (without internal flyback generator)

TYPICAL BLACK-WHITE TV APPLICATION FOR 14" – 110° SCREEN (with yoke L = 27 mH, R = 15Ω, I_{pp} = 0.5A)

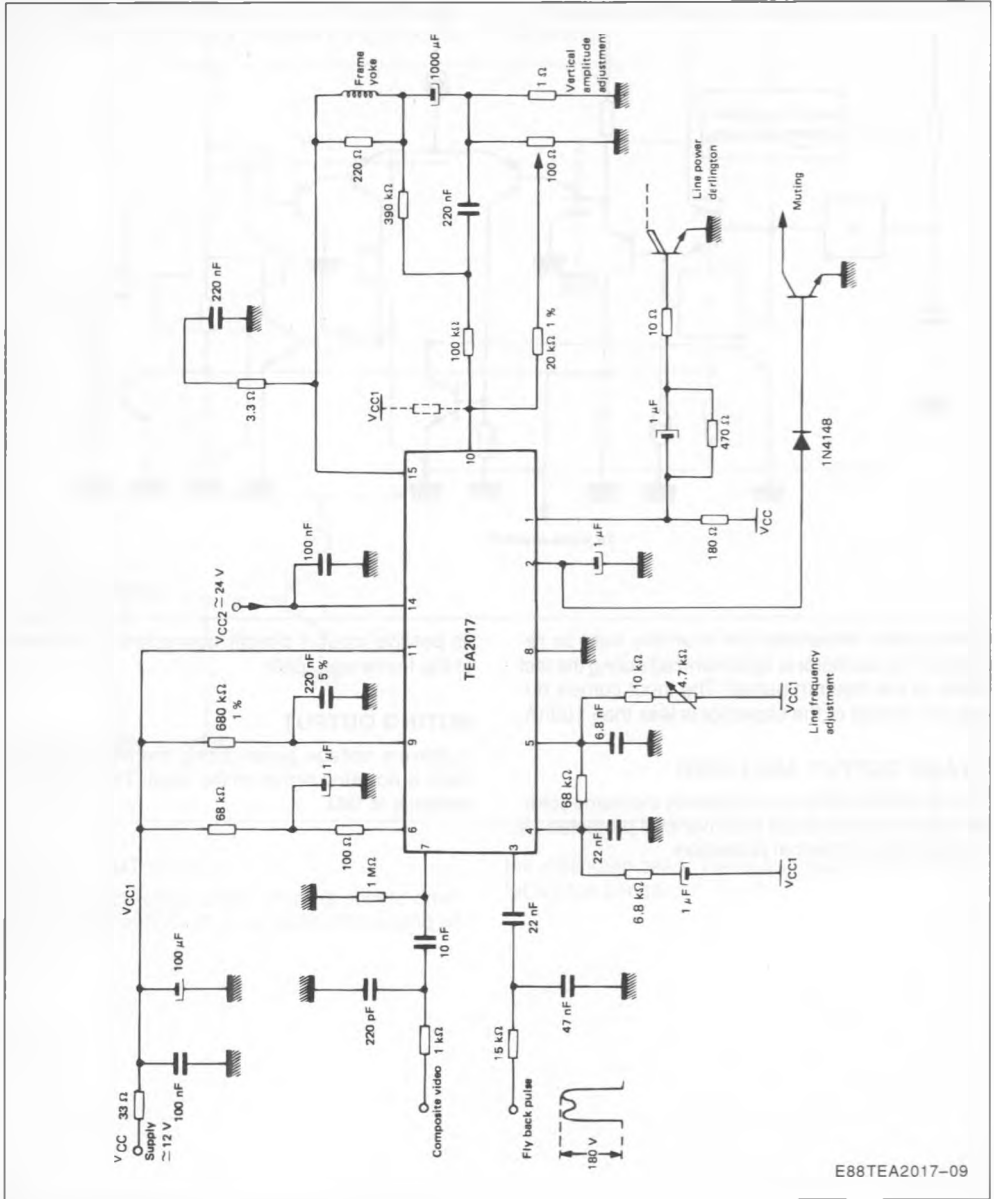

E88TEA2017-09

V_{CC2} : Power stage supply from high voltage transformer.
V_{CC1} must be perfectly filtered.

APPLICATION N°2 (with internal flyback generator)

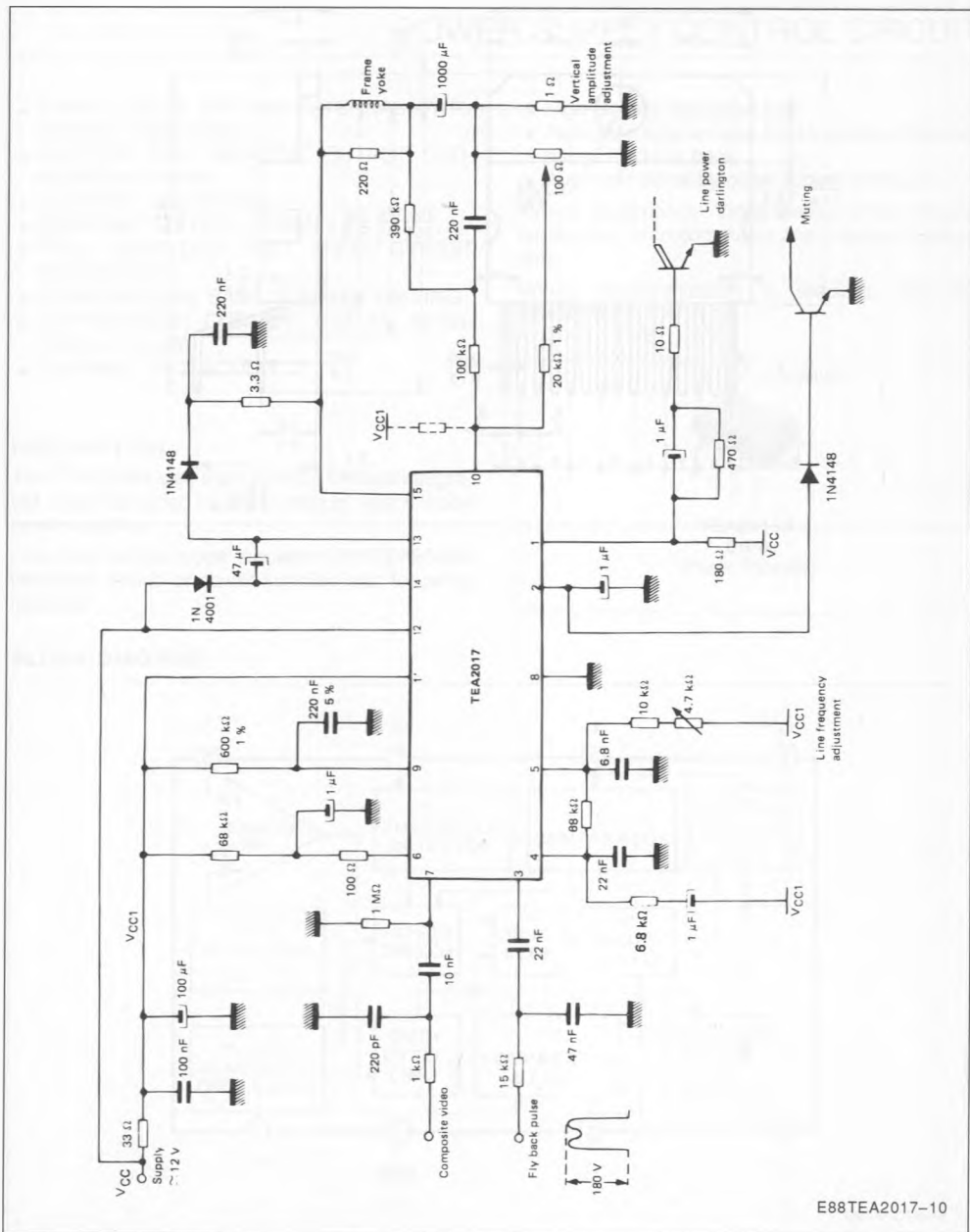
TYPICAL BLACK-WHITE TV APPLICATION FOR 14" - 110° SCREEN (with yoke L = 27 mH, R = 15 Ω , I_{pp} = 0.5A)

PACKAGE MECHANICAL DATA

15 PINS – PLASTIC SIP

