

TDA6800

Video Modulator Circuit

Product Specification

Linear Products

DESCRIPTION

The TDA6800 is a modulator circuit for modulation of video signals on a VHF/UHF carrier. The circuit requires a 5V power supply and few external components for the negative modulation mode. For positive modulation an external clamp circuit is required. This circuit can be used as a general-purpose modulator without additional external components.

FEATURES

- **Balanced modulator**
- **Symmetrical oscillator**
- **Video clamp circuit for negative modulation**
- **Frequency range 50 to 800MHz**

APPLICATIONS

- **Video modulators**
- **General-purpose modulators**
- **Computers**

PIN CONFIGURATION

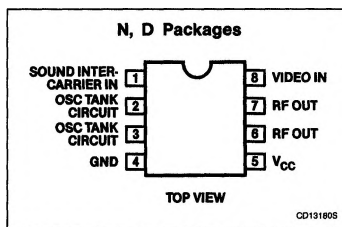

ORDERING INFORMATION

DESCRIPTION	TEMPERATURE RANGE	ORDER CODE
8-Pin Plastic DIP (SOT-97A)	-25°C to 85°C	TDA6800N
8-Pin Plastic SO (SOT-96A)	-25°C to +85°C	TDA6800TD

BLOCK DIAGRAM

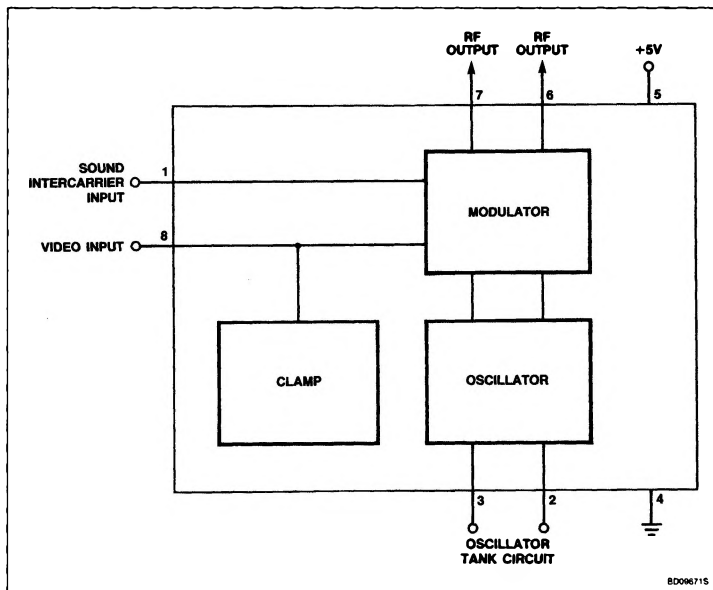

Video Modulator Circuit

TDA6800

ABSOLUTE MAXIMUM RATINGS

SYMBOL	PARAMETER	RATING	UNIT
V_{CC}	Supply voltage	7	V
V_{B-4}	Input voltage	4	V
$V_{6,7-4}$	Output voltage	9	V
T_{STG}	Storage temperature	-65 to +150	°C
T_J	Junction temperature	125	°C
T_A	Operating ambient temperature range	-65 to +85	°C
θ_{JA}	Thermal resistance from junction to ambient in free air	260	°C/W
	TDA6800T TDA6800	120	°C/W

DC AND AC ELECTRICAL CHARACTERISTICS $V_{CC} = 5V$; $T_A = 25^\circ C$; unless otherwise specified.

SYMBOL	PARAMETER	LIMITS			UNIT
		Min	Typ	Max	
V_{CC}	Supply voltage range	4.5		5.5	V
I_{CC}	Supply current consumption		9	13	mA
$V_{B(P-P)}$	Video input voltage		1		V
R_B	Input impedance	30			k Ω
V_B	Voltage (DC) at video input (clamp voltage)		1.4		V
V_1	Voltage (DC) at sound input		2.5		V
V_{6-7}	Output voltage $f = 50\text{MHz}$; $R_L = 75\Omega$		13		mV
V_{6-7}	Output voltage $f = 600\text{MHz}$; $R_L = 75\Omega$		10		mV
Δ_G	Differential gain			10	%
Δ_ϕ	Differential phase			10	deg.
	Intermodulation ¹ (1.1MHz)		-80	-60	dB
Δ_F	Frequency shift $V_B = 5\%$, $f = 600\text{MHz}$			100	kHz
Δ_F	Frequency shift $V_B = 5\%$, $f = 800\text{MHz}$		TBD		kHz
Δ_F	Frequency drift 25 to 40°C			100	kHz
Δ_F	Frequency drift 15 to 55°C			300	kHz
Positive modulation (see Figure 2)					
V_R	Residual carrier voltage			2.5	%
α	Cross modulation ²		0.1	0.25	%

NOTES:

- Input signal: DC 0.45V ($V_{B-4} = 1.85V$)
4.4MHz; input voltage (P-P) = 0.6V
5.5MHz; input voltage (P-P) = 1.26V
measured with respect to picture carrier, at $f = 600\text{MHz}$.
- Input signal: DC 1V ($V_{B-4} = 3.5V$)
5.5MHz AM modulated, $f_M = 100\text{kHz}$
 $m = 0.8$; input voltage (P-P) = 2.27V (including modulation)
measured with respect to the picture carrier, at $f = 600\text{MHz}$.

Video Modulator Circuit

TDA6800

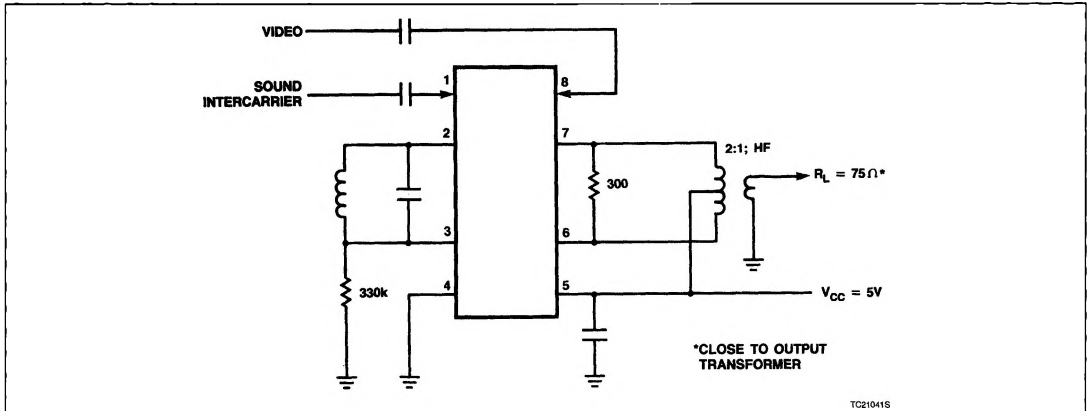

Figure 1. Application for Negative Modulation

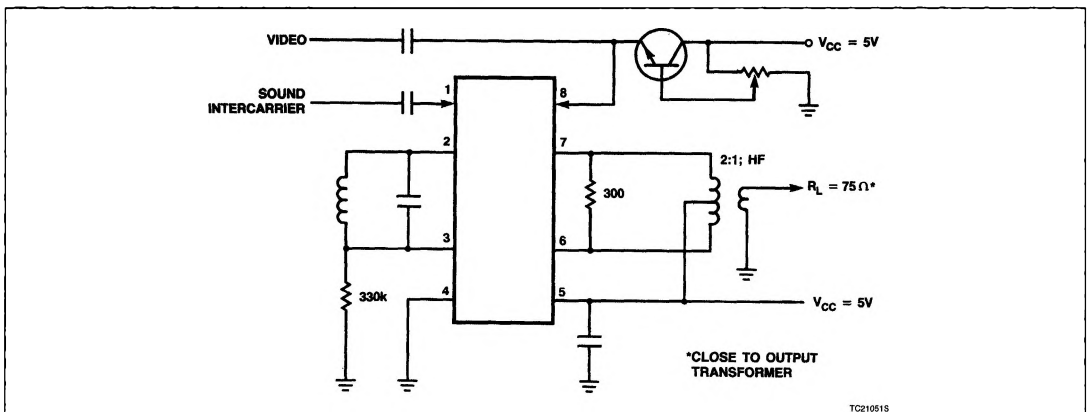

Figure 2. Application for Positive Modulation

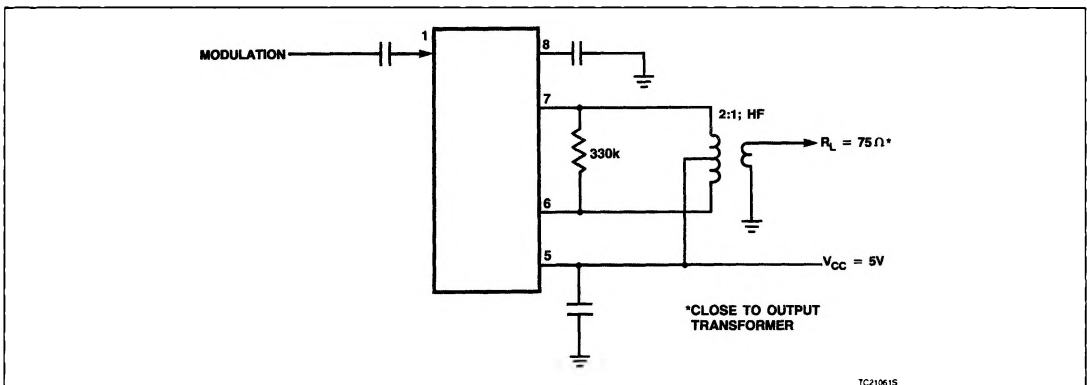

Figure 3. Application for General-Purpose Modulation