

**GENERAL DESCRIPTION**

The TDA4503 combines all small signal functions (except the tuner) which are required for a monochrome television receiver.

For a complete monochrome television receiver only output stages are required to be added for horizontal and vertical deflection, video and sound. The TDA4503 can also be used in simple colour television receivers. In this application an external sandcastle pulse generator is required.

It incorporates the following functions:

- vertical sync separator/oscillator
- vertical output
- coincidence detector (sound mute)
- phase detector/frequency control
- a.g.c. detector
- sync separator
- horizontal oscillator
- synchronous demodulator
- vision i.f. amplifier
- tuner a.g.c.
- d.c. volume control
- a.f.c. detector
- video output
- sound demodulator
- audio output
- gate pulse generator
- sound limiter/feedback
- 90° phase shift
- overload detector
- horizontal output

**QUICK REFERENCE DATA**

Supply voltage	$V_{7-10}, V_{22-10}$	typ.	10.5	V
Supply current	$I_7$	typ.	75	mA
Supply current	$I_{22}$	typ.	4.5	mA
Operating ambient temperature range	$T_{amb}$		–25 to +65	°C
Storage temperature range	$T_{stg}$		–25 to +150	°C
Power dissipation	$P_{tot}$	max.	1.7	W

**PACKAGE OUTLINE**

28-lead DIL; plastic, with internal heat spreader (SOT-117).

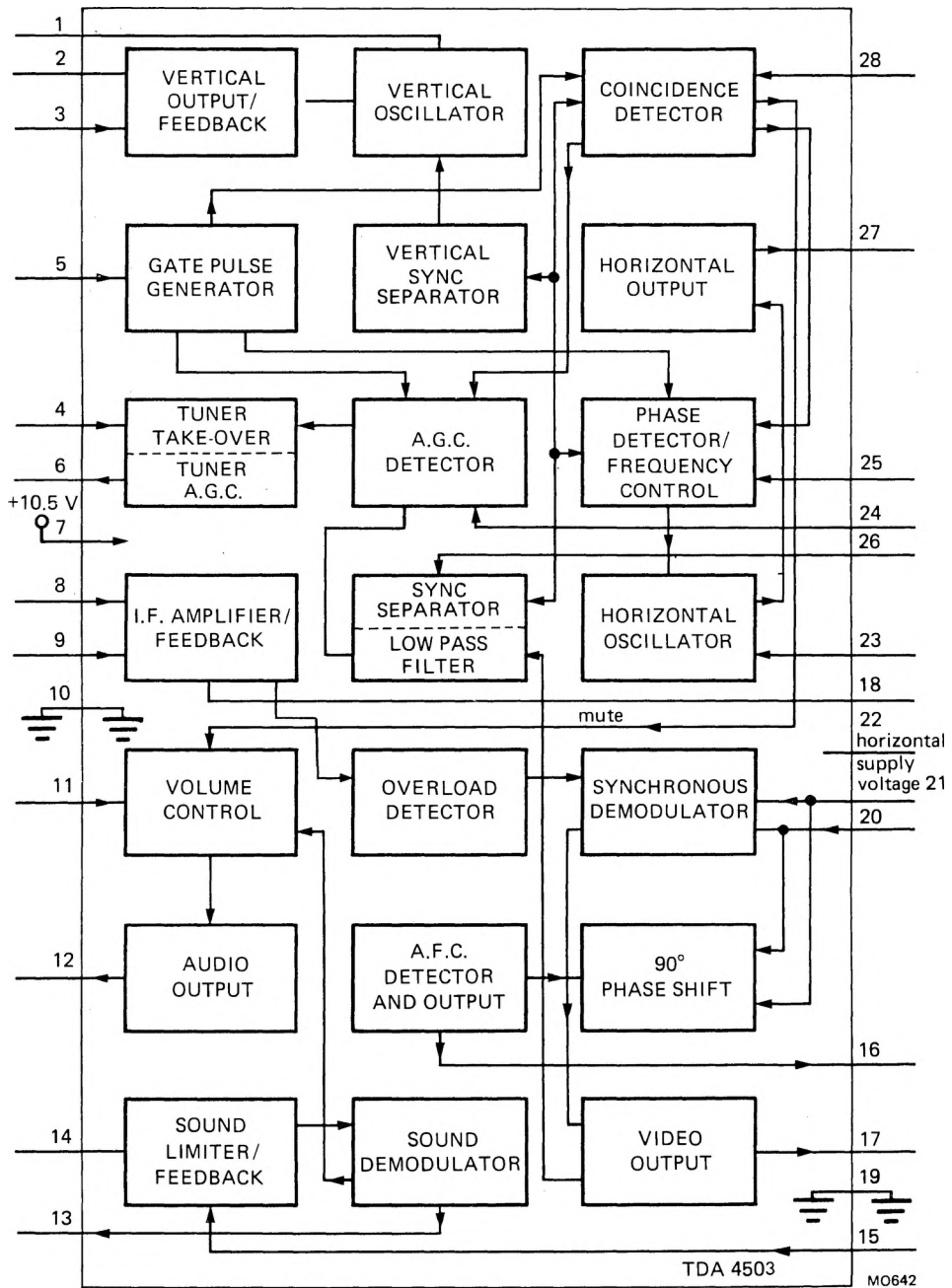

Fig. 1 Block diagram.

**SMALL SIGNAL COMBINATION FOR MONOCHROME TV****TDA4503****PINNING**

Pin number	function	Pin number	function
1.	vertical oscillator	15.	sound i.f.
2.	vertical output	16.	a.f.c. output
3.	vertical feedback	17.	video output
4.	top linearity	18.	decoupling capacitor
5.	flyback pulse	19.	ground
6.	tuner a.g.c.	20.	38,5 MHz reference
7.	+10,5 V supply	21.	(38,9 MHz reference)
8.	i.f. input	22.	horizontal supply voltage
9.		23.	horizontal oscillator
10.	ground	24.	top sync detector
11.	volume control	25.	phase detector
12.	sound output	26.	sync separator
13.	6 MHz tuning (5,5 MHz tuning)	27.	horizontal output
14.	decoupling	28.	mute/coincidence detector

**FUNCTIONAL DESCRIPTION (Fig. 1)**

A complete black-and-white receiver can be built around this circuit by adding only the output stages for horizontal and vertical deflection with the video and sound output stages. The TDA4503 can also be used in simple colour television receivers using an external circuit to generate the sandcastle.

The block diagram (Fig. 1) depicts the various functions which are described briefly below.

The sensitivity of the i.f. amplifier is  $70 \mu\text{V}$  for a peak-to-peak output voltage of 3 V (compare the TDA3541). This amplifier has a symmetrical input (pins 8 and 9) and is followed by a synchronous demodulator. The external tuned circuit is connected to pins 20 and 21. This circuit provides the information for the a.f.c. circuit, the  $90^\circ$  phase shift being supplied by internal RC-networks. An a.f.c. output with a voltage swing of about 9 V is obtained from pin 17 ( $V_{7-10} = 10.5 \text{ V}$ ).

The a.g.c. detector is gated to reduce sensitivity to external electrical noise and the a.g.c. time constant network is connected to pin 24. Gain control range of the i.f. amplifier is greater than 60 dB. Adjustments of the tuner take-over point is made at pin 4. When the voltage at pin 4 is approximately 3.5 V the direction of the tuner control voltage is positive-going. When the voltage at pin 4 is approximately 8 V the direction of the tuner control voltage is negative-going.

An output signal of 3 V (p-p) is obtained from the video amplifier (top sync level 1.5 V) with negative-going sync. Since the sound signal is derived from pin 16 (see Fig. 4) the video output is not blanked during the flyback period. As shown in the application circuit (Fig. 4) the band-pass filter for the sound must be connected between video output (pin 16) and sound i.f. input (pin 15). Sound information passes through a sound limiter network and a sound demodulator circuit with an external tuned circuit for this stage connected to pin 13. The demodulator is followed by a volume control stage with a control range of 80 dB and an output amplifier with an audio output signal of 170 mV (r.m.s.) for a  $\Delta f$  of 7.5 kHz and at maximum volume setting.

The slicing level of the sync separator is referred to the top sync and is determined by the values of external resistors, the recommended slicing level being 30%. Noise protection is provided for the sync separator stage. Separated sync pulses are supplied to the gated phase detector which compare the sync pulses with the sawtooth voltage obtained from the horizontal flyback pulse (pin 5). During catching the gating of the phase detector is switched off and the phase detector output current is increased.

The in-sync or out-of-sync condition is detected with the coincidence detector which is also used for transmitter identification. Sound output is suppressed when no input signal is available. Clamping the voltage on pin 28 to a level of 3.5 V sets the phase detector to a high output current, short time constant mode. This is appropriate for the reception of VCR signals.

Phase detector output voltage levels maintain the horizontal oscillator at its correct operating frequency. The push-pull output (pin 27) has a typical duty cycle of 40%.

Vertical sync pulses are obtained from an internal integrating network with the vertical sawtooth being generated in the vertical oscillator. This sawtooth voltage is compared with the feedback voltage from the deflection coil via pin 3. The comparator generates the drive voltage for the vertical deflection output stage.

The TDA4503 has four supply pins. Pin 7 and pin 10 are for the main positive supply and circuit ground respectively.

Critical circuits are grounded by pin 19. Pin 22 is the supply for the horizontal oscillator. A low current supply (5 mA minimum) can be used to start the oscillator from an external high voltage supply rail.

## RATINGS

Limiting values in accordance with the Absolute Maximum System (IEC134)

Supply voltage	$V_{7-10}, V_{22-10}$	max.	13.2	V
Total power dissipation	$P_{tot}$	max.	1.7	W
Storage temperature range	$T_{stg}$		-25 to +150	°C
Operating ambient temperature range	$T_{amb}$		-25 to +65	°C

## CHARACTERISTICS

 $V_{7-10} = 10.5$  V,  $V_{22-10} = 10.5$  V and  $T_{amb} = 25$  °C unless otherwise specified

parameter	symbol	min.	typ.	max.	unit
Supply voltage	$V_{7-10}$	9.5	10.5	13.2	V
Supply current	$I_7$	—	75	—	mA
Supply voltage (horizontal oscillator)	$V_{22-10}$	9.5	10.5	13.2	V
Supply current (horizontal oscillator, note 1)	$I_{22}$	—	4.5	—	mA
Power dissipation	$P_{tot}$	—	850	—	mW
<b>Vision i.f. amplifier (pin 8)</b>					
Input sensitivity (onset of a.g.c.) at 39.5 MHz (note 2)	$V_{i(rms)}$	—	70	—	μV
Differential input resistance (note 3)	$R_i$	—	800	—	Ω
Differential input capacitance (note 3)	$C_i$	—	6	—	pF
Gain control range	$\Delta G$	—	56	—	dB
Output signal expansion for 50 dB input signal variation (note 4)	$\Delta V_o$	—	1	—	dB
Maximum input signal	$V_{i max}$	—	50	—	mV
<b>Video amplifier (note 5)</b>					
Zero signal output level (note 6)	$V_{16-10}$	—	5	—	V
Top sync output level (note 7)	$V_{16-10}$	1.2	1.4	1.6	V
Video output signal amplitude (peak-to-peak value)	$V_{16-10(p-p)}$	2.75	3.0	3.25	V
Internal bias current of n-p-n emitter follower output transistor	$I_B$	1.4	2.0	—	mA
Bandwidth of demodulated output signal	B	5	6	—	MHz
Video non-linearity (note 8)		—	—	10	%

## SMALL SIGNAL COMBINATION FOR MONOCHROME TV

TDA4503

## CHARACTERISTICS (continued)

parameter	symbol	min.	typ.	max.	unit
<b>Tuner a.g.c.</b>					
Take-over voltage (pin 4) for positive-going tuner a.g.c. (n-p-n tuner)	$V_{4-10}$	—	3.5	—	V
Take-over voltage (pin 4) for negative-going tuner a.g.c. (p-n-p tuner)	$V_{4-10}$	—	8	—	V
Maximum tuner a.g.c. output swing	$I_6 \text{ max}$	2	3	—	mA
Output saturation voltage at $I_6 = 2 \text{ mA}$	$V_{6-10(\text{sat})}$	—	—	300	mV
Leakage current	$I_6$	—	—	1	$\mu\text{A}$
<b>A.F.C. circuit (note 9)</b>					
A.F.C. output voltage swing	$V_{17-19}$	9	—	10	V
Available output current	$\pm I_{17}$	—	1	—	mA
Output voltage at nominal tuning of the reference tuned circuit	$V_{17-19}$	—	5.25	—	V
<b>Sound circuit</b>					
Input limiting voltage when $V_O = V_{O\text{max}} - 3 \text{ dB}$ (note 10)	$V_{14 \text{ lim}}$	—	400	—	$\mu\text{V}$
Input resistance at pin 15 (note 11)	$R_i$	—	3	—	$\text{k}\Omega$
A.F. output signal at pin 12 (note 12) (r.m.s. value)	$V_{12-10(\text{rms})}$	170	—	240	mV
<b>Volume control (pin 11) (Fig. 3)</b>					
Voltage with pin 11 disconnected	$V_{11-10}$	—	6.5	—	V
Current pin 11 short-circuited to ground	$I_{11}$	—	1	—	mA
Volume control characteristic (note 13)			See Fig. 3		
Value of external control resistor	$R_{11-10}$	—	5	—	$\text{k}\Omega$

parameter	symbol	min.	typ.	max.	unit
<b>Horizontal synchronization circuit</b>					
Slicing level sync separator (note 14)		—	30	—	%
Holding range PLL		—	±1000	—	Hz
Catching range PLL		—	±600	—	Hz
Control sensitivity video to flyback (note 15)		—	2	—	kHz/μs
<b>Horizontal oscillator</b>					
Free running frequency	$f_{osc}$	—	15625	—	Hz
Spread with fixed external components	$\Delta f_{osc}$	—	—	4	%
Frequency variations due to supply voltage changes (note 16)	$\Delta f_{osc}/\Delta V$	—	0	—	%
Frequency variation with temperature	$\Delta f_{osc}/\Delta T$	—	—	$1 \times 10^{-4}$	K <sup>-1</sup>
Maximum frequency shift	$\Delta f_{osc}$	—	—	10	%
Maximum frequency deviation between starting point output and nominal condition	$\Delta f_{osc}$	—	—	10	%
<b>Horizontal (push-pull) output</b>					
Output current	$I_{27}$	10	—	—	mA
Output impedance	$R_{27-10}$	—	200	—	Ω
Voltage when $I_{27} = 10$ mA	$V_{27-10}$	—	2	—	V
	$V_{27-22}$	—	3	—	V
Duty cycle of output pulse (note 17)	$\delta$	0.35	0.40	0.45	
<b>Flyback input (note 18)</b>					
Minimum required input amplitude (peak-to-peak value)	$V_{5-10(p-p)}$	—	4	—	V
Phase detector switching voltage		—	0	—	V

## CHARACTERISTICS (continued)

parameter	symbol	min.	typ.	max.	unit
<b>Coincidence detector (mute)</b> (note 19)					
Voltage in synchronized condition	$V_{28-19}$	—	9.5	—	V
Voltage in non-synchronized condition (no-signal)	$V_{28-19}$	—	1.0	1.5	V
Switching level to switch phase detector from slow to fast	$V_{28-19}$	4.5	5.0	5.5	V
Switching level to activate the 'mute' function (transmitter identification)	$V_{28-19}$	2.25	2.5	2.75	V
Output current; in-sync (peak-to-peak value)	$I_{28(p-p)}$	—	1	—	mA
<b>Vertical oscillator</b>					
Free running frequency	$f_{osc}$	—	47.5	—	Hz
Spread with fixed external components	$\Delta f_{osc}$	—	—	4	%
Holding range at nominal frequency		52.5	—	—	Hz
Temperature coefficient	TC	—	$1 \times 10^{-4}$	—	$K^{-1}$
Frequency shift due to a supply voltage change from 9.5 to 12 V	$\Delta f_{osc}/\Delta V$	—	5	—	%
<b>Vertical output (pin 2)</b>					
Output current	$I_2$	1	1.3	—	mA
Output resistance	$R_{2-10}$	—	2	—	$k\Omega$
<b>Feedback input (pin 3)</b>					
D.C. input voltage	$V_{3-10}$	4.75	5	5.25	V
A.C. input voltage (peak-to-peak value)	$V_{3-10(p-p)}$	—	1.2	—	V
Input current	$I_3$	—	—	10	$\mu A$
Non-linearity of deflection current at $V_p = 10.5$ V		—	—	2.5	%



## Notes to characteristics

1. It is possible to start the horizontal oscillator by supplying a current of 5 mA which can be taken from the mains rectifier, to pin 22. The main supply (pin 7) can then be derived from the horizontal output stage.
2. I.F. input voltage (r.m.s.) – value at top sync level at which the video amplitude has dropped 0,5 dB compared with the amplitude at an input signal of 10 mV.
3. The input impedance has been chosen such that a SAW-filter can be applied. 800  $\Omega$  is an acceptable compromise between the requirements for triple transient suppression and power loss.
4. Measured with 0 dB = 150  $\mu$ V.
5. Measured at 10 mV(r.m.s.) top sync input signal.
6. With switched demodulator.
7. Signal with negative-going sync with top white being 10% of the top sync amplitude (Fig. 2).
8. This figure is valid for the complete video signal amplitude (peak-white to top sync).
9. Measured with an input signal ( $V_{8-g}$ ) of 10 mV(r.m.s.); the a.f.c. output (pin 7) loaded with 2 x 100 k $\Omega$  between the supply and ground. The Q factor of the reference tuned circuit is 50.
10. Voltage at pin 15 is the r.m.s. value.  $Q_L$  of the demodulator tuned circuit is 20. Audio frequency is 1 kHz and the carrier frequency is 5.5 MHz.
11. Measured with an input signal of 1 mV(r.m.s.)
12. The tuned demodulator circuit must give an output level equal to that given in the "mute" condition.
13. Volume can be controlled using a variable resistor connected to ground (nominal 5 k $\Omega$ ) or by means of a variable d.c. voltage. In this latter case the rather low impedance at pin 11 must be taken into account.

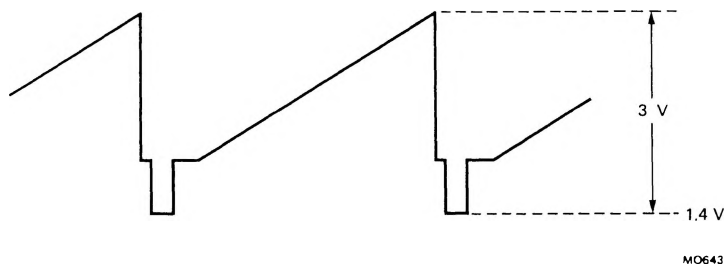

Fig. 2 Video output signal.

## Notes to characteristics (continued)

14. The sync separator is noise gated. The slicing level is referred to top sync level and is independent of the video information. The value given is a percentage of the sync pulse amplitude. The slicing depends on the values of external resistors connected to pin 26.
15. Phase detector current increases by a factor of 7 during "catching" and when phase detector operates in the 'FAST' mode (pin 28). This ensures a high catching range and a higher dynamic loop gain.
16. Supply voltage variation in the range 8 to 12 V.
17. The negative-going edge of this pulse initiates the switch-off of the horizontal output transistor (simultaneous driver).
18. The circuit requires an integrated flyback pulse. The gate pulses for a.g.c. and the coincidence detector are obtained from the sawtooth.
19. The functions of in-sync/out-of-sync and transmitter identification have been combined on pin 28. For reception of VCR-signals the voltage on this pin must be fixed between 3 V and 4.5 V so that the time constant is fast and the sound is still available.

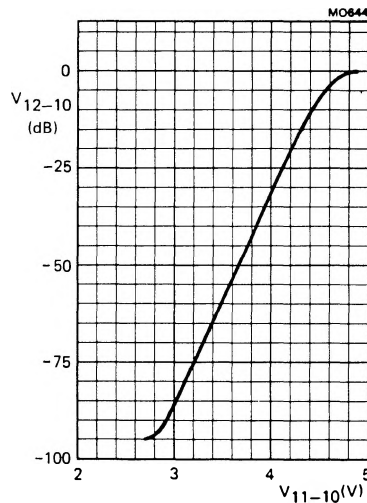

Fig. 3 Volume control characteristic at  $f = 1$  kHz.

APPLICATION INFORMATION

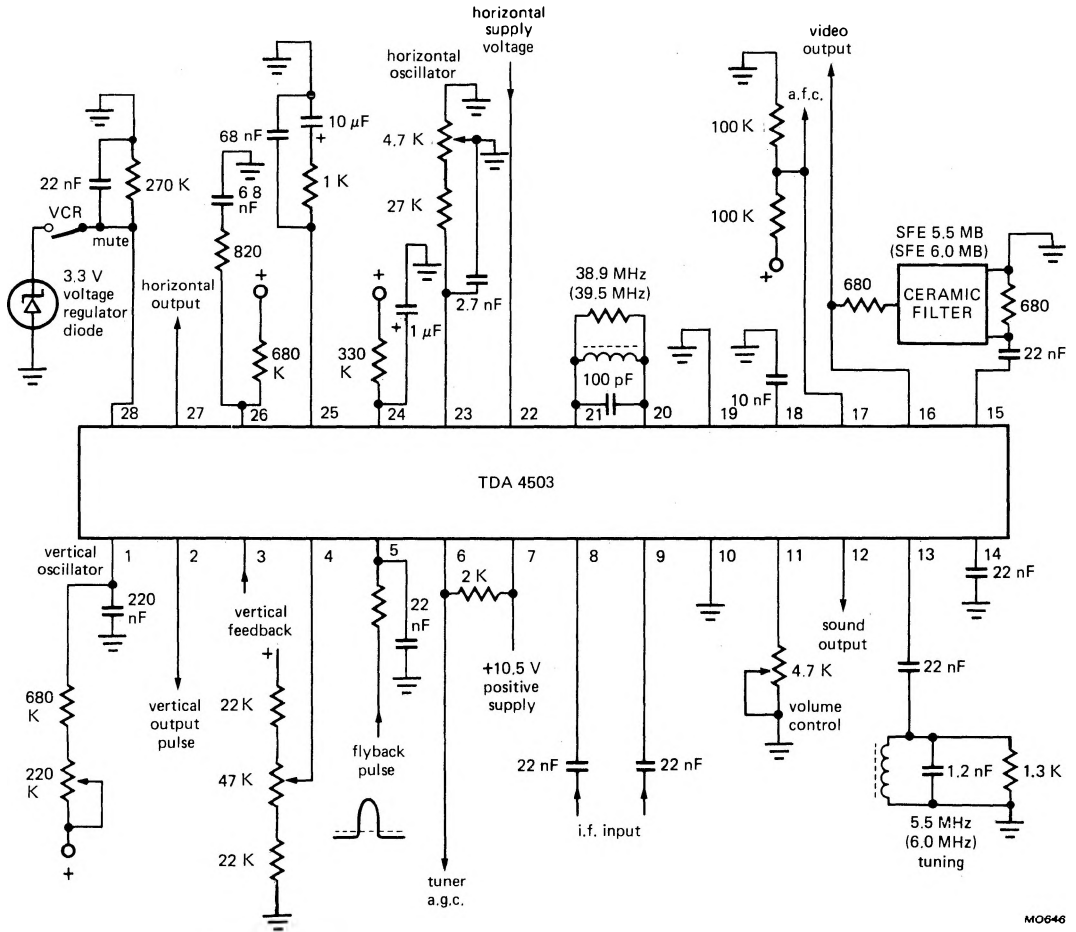

Fig. 4 Typical application circuit.

MO646