

TBP18S030, TBP18SA030
256 BITS (32 WORDS BY 8 BITS)
PROGRAMMABLE READ-ONLY MEMORIES

SDMS024 – SEPTEMBER 1979 – REVISED AUGUST 1984

- **Titanium-Tungsten (Ti-W) Fuse Link for Reliable Low-Voltage Full Family Compatible Programming**
- **Full Decoding and Fast Chip Select Simplify System Design**
- **P-N-P Inputs for Reduced Loading on System Buffers/Drivers**
- **Applications Include:**
 - Microprogramming/Firmware Loaders
 - Code Converters/Character Generators
 - Translators/Emulators
 - Address Mapping/Look-Up Tables
- **Choice of 3-State or Open-Collector Outputs**

TBP18SA030, TBP18S030 . . . J OR N PACKAGE
(TOP VIEW)

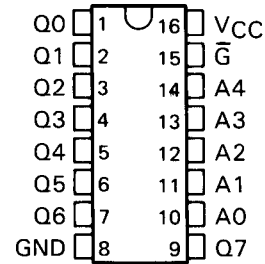

description

These monolithic TTL programmable read-only memories (PROMs) feature titanium-tungsten (Ti-W) fuse links with each link designed to program in 20 microseconds. The Schottky-clamped versions of these PROMs offer considerable flexibility for upgrading existing designs or improving new designs as they feature full Schottky clamping for improved performance, low-current MOS-compatible p-n-p inputs, choice of bus-driving three-state or open-collector outputs, and improved chip-select access times.

Data can be electronically programmed, as desired, at any bit location in accordance with the programming procedure specified. All PROMs are supplied with a low-logic level output condition stored at each bit location. The programming procedure open-circuits Ti-W metal links, which reverses the stored logic level at selected locations. The procedure is irreversible; once altered, the output for that bit location is permanently programmed. Outputs that have never been altered may later be programmed to supply the opposite output level. Operation of the unit within the recommended operating conditions will not alter the memory content.

A low level at the chip-select input(s) enables each PROM. The opposite level at any chip-select input causes the outputs to be off.

The three-state output offers the convenience of an open-collector with the speed of a totem-pole output; it can be bus-connected to other similar outputs yet it retains the fast rise time characteristic of the TTL totem-pole output. The open-collector output offers the capability of direct interface with a data line having a passive pull up.

A MJ suffix designates full-temperature circuits (formerly 54 Family) and are characterized for operation over the full military temperature range of -55°C to 125°C . A J or N suffix designates commercial-temperature circuits (formerly 74 Family) and are characterized for operation from 0°C to 70°C .

TBP18S030, TBP18SA030 256 BITS (32 WORDS BY 8 BITS) PROGRAMMABLE READ-ONLY MEMORIES

SDMS024 – SEPTEMBER 1979 – REVISED AUGUST 1984

logic symbol

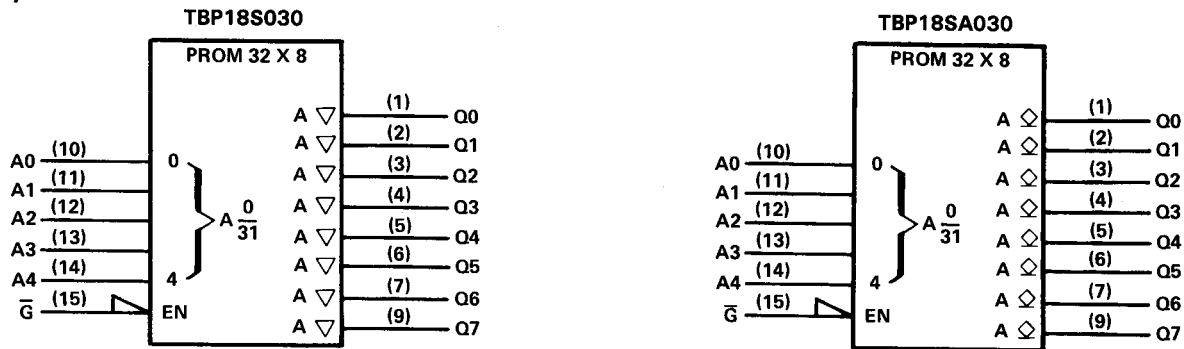

schematics of inputs and outputs

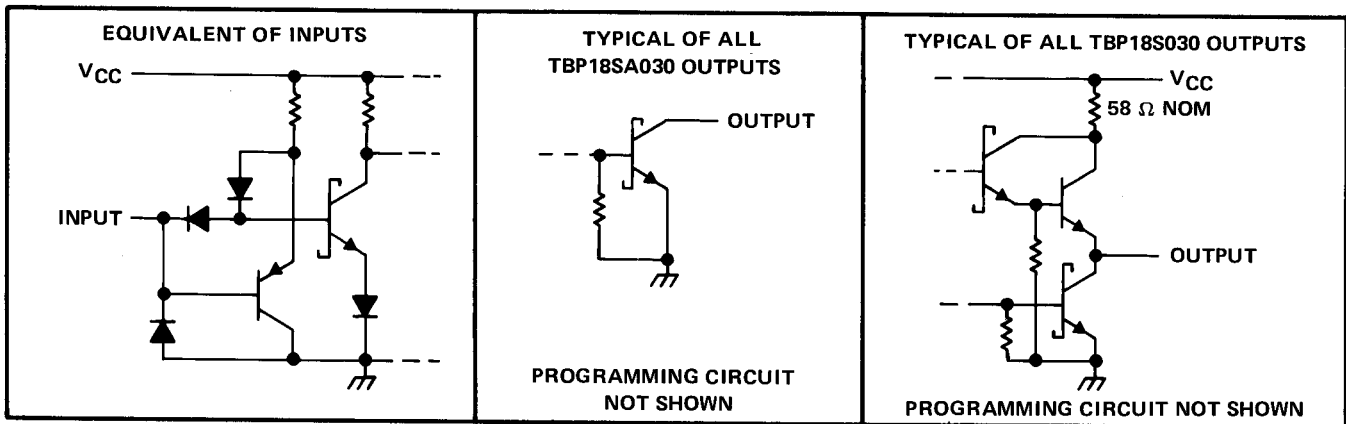

absolute maximum ratings over operating free-air temperature range (unless otherwise noted)

Supply voltage (see Note 1)	7V
Input voltage	5.5V
Off-state output voltage	5.5V
Operating free-air temperature range: Full-temperature-range circuits	-55°C to 125°C
Commercial-temperature-range circuits	0°C to 70°C
Storage temperature range	-65°C to 150°C

recommended conditions for programming TBP18S', TBP18SA PROMs

		MIN	NOM	MAX	UNIT
Supply voltage, V_{CC} (see Note 1)	Steady state	4.75	5	5.25	V
	Program pulse	9	9.25	9.5	
Input voltage	High level, V_{IH}	2.4		5	V
	Low level, V_{IL}	0		0.5	
Termination of all outputs except the one to be programmed		See load circuit (Figure 1)			
Voltage applied to output to be programmed, $V_{O(pr)}$ (see Note 2)		0	0.25	0.3	V
Duration of V_{CC} programming pulse X (see Figure 2 and Note 3)		15	25	100	μs
Programming duty cycle for Y pulse			25	35	%
Free-air temperature		20	25	30	°C

NOTES: 1. Voltage values are with respect to network ground terminal. The supply voltage rating does not apply during programming.
2. The TBP18S030, TBP18SA030 are supplied with all bit locations containing a low logic level, and programming a bit changes the output of the bit to high logic level.



POST OFFICE BOX 655303 • DALLAS, TEXAS 75265

programming procedure

1. Apply steady-state supply voltage ($V_{CC} = 5\text{ V}$) and address the word to be programmed.
2. Verify that the bit location needs to be programmed. If not, proceed to the next bit.
3. If the bit requires programming, disable the outputs by applying a high-logic level voltage to the chip-select input(s).
4. Only one bit location is programmed at a time. Connect each output not being programmed to 5 V through 3.9 k Ω and apply the voltage specified in the table to the output to be programmed. Maximum current into the programmer output is 150 mA.
5. Step V_{CC} to 9.25 nominal. Maximum supply current required during programming is 750 mA.
6. Apply a low-logic-level voltage to the chip-select input(s). This should occur between 1 μs and 1 ms after V_{CC} has reached its 9.25 level. See programming sequence of Figure 2.
7. After the X pulse time is reached, a high logic level is applied to the chip-select inputs to disable the outputs.
8. Within the range of 1 μs to 1 ms after the chip-select input(s) reach a high logic level, V_{CC} should be stepped down to 5 V at which level verification can be accomplished.
9. The chip-select input(s) may be taken to a low logic level (to permit program verification) 1 μs or more after V_{CC} reaches its steady-state value of 5 V.
10. At a Y pulse duty cycle of 35% or less, repeat steps 1 through 8 for each output where it is desired to program a bit.
11. Verify accurate programming of every word after all words have been programmed using V_{CC} values of 4.5 and 5.5 volts.

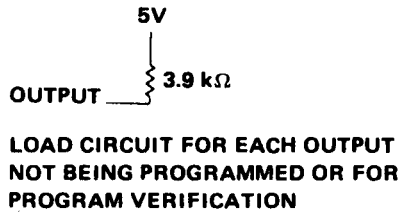

FIGURE 1 – LOAD CIRCUIT

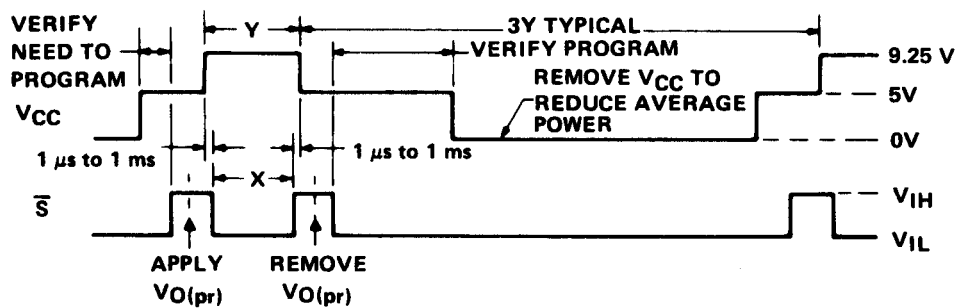

FIGURE 2 – VOLTAGE WAVEFORMS FOR PROGRAMMING

TBP18S030, TBP18SA030
256 BITS (32 WORDS BY 8 BITS)
PROGRAMMABLE READ-ONLY MEMORIES

SDMS024 – SEPTEMBER 1979 – REVISED AUGUST 1984

recommended operating conditions (see Note 4)

PARAMETER		TBP18S030			UNIT
		MIN	NOM	MAX	
Supply voltage, V_{CC}	MJ	4.5	5	5.5	V
	J, N	4.75	5	5.25	
High-level output current, I_{OH}	MJ			-2	mA
	J, N			-6.5	
Low-level output current, I_{OL}				20	mA
Operating free-air temperature, T_A	MJ	-55		125	°C
	J, N	0		70	

electrical characteristics over recommended operating free-air temperature range (unless otherwise noted) (see Note 4)

PARAMETER	TEST CONDITIONS†	FULL TEMP (MJ)			COMM. TEMP (J, N)			UNIT
		MIN	TYP‡	MAX	MIN	TYP‡	MAX	
V_{IH} High-level input voltage		2			2			V
V_{IL} Low-level input voltage		0.8			0.8			V
V_{IK} Input clamp voltage	$V_{CC} = \text{MIN}, I_I = -18 \text{ mA}$	-1.2			-1.2			V
V_{OH} High-level output voltage	$V_{CC} = \text{MIN}, V_{IH} = 2 \text{ V}, V_{IL} = 0.8 \text{ V}, I_{OH} = \text{MAX}$	2.4	3.4		2.4	3.2		V
V_{OL} Low-level output voltage	$V_{CC} = \text{MIN}, V_{IH} = 2 \text{ V}, V_{IL} = 0.8 \text{ V}, I_{OL} = \text{MAX}$	0.5			0.5			V
I_{OZH} Off-state output current, high-level voltage applied	$V_{CC} = \text{MAX}, V_{IH} = 2 \text{ V}, V_O = 2.4 \text{ V}$	50			50			μA
I_{OZL} Off-state output current, low-level voltage applied	$V_{CC} = \text{MAX}, V_{IH} = 2 \text{ V}, V_O = 0.5 \text{ V}$	-50			-50			μA
I_I Input current at maximum input voltage	$V_{CC} = \text{MAX}, V_I = 5.5 \text{ V}$	1			1			mA
I_{IH} High-level input current	$V_{CC} = \text{MAX}, V_I = 2.7 \text{ V}$	25			25			μA
I_{IL} Low-level input current	$V_{CC} = \text{MAX}, V_I = 0.5 \text{ V}$	-0.25			-0.25			mA
I_{OS} Short-circuit output current§	$V_{CC} = \text{MAX}$	-30		-100	-30		-100	mA
I_{CC} Supply current	$V_{CC} = \text{MAX}$, Chip select(s) at 0 V, Outputs open, See Note 5		80	110		80	110	mA

switching characteristics over recommended ranges of T_A and V_{CC} (unless otherwise noted)

TYPE	TEST CONDITIONS	$t_a(\text{A})$ ACCESS TIME FROM ADDRESS			$t_a(\text{S})$ ACCESS TIME FROM CHIP SELECT (ENABLE TIME)			t_{dis} DISABLE TIME FROM HIGH OR LOW LEVEL			UNIT
		MIN	TYP‡	MAX	MIN	TYP‡	MAX	MIN	TYP‡	MAX	
TBP18S030MJ	$C_L = 30 \text{ pF}$ for $t_a(\text{A})$ and $t_a(\text{S})$,		25	50		12	30		8	30	ns
TBP18S030	5 pF for t_{dis} , See Note 6		25	40		12	25		8	20	ns

†For conditions shown as MIN or MAX, use the appropriate value specified under recommended operating conditions.

‡All typical values are at $V_{CC} = 5 \text{ V}, T_A = 25^\circ\text{C}$.

§Not more than one output should be shorted at a time and duration of the short circuit should not exceed one second.

NOTES: 4. MJ designates full-temperature circuits (formerly 54 Family), J and N designate commercial-temperature circuits (formerly 74 Family).

5. The typical values of I_{CC} are with all outputs low.



TBP18S030, TBP18SA030
256 BITS (32 WORDS BY 8 BITS)
PROGRAMMABLE READ-ONLY MEMORIES

SDMS024 – SEPTEMBER 1979 – REVISED AUGUST 1984

recommended operating conditions (see Note 4)

PARAMETER		TBP18SA030			UNIT
		MIN	NOM	MAX	
Supply voltage, V_{CC}	MJ	4.5	5	5.5	V
	J, N	4.75	5	5.25	
High-level output voltage, V_{OH}				5.5	V
Low-level output current, I_{OL}				20	mA
Operating free-air temperature, T_A	MJ	-55		125	°C
	J, N	0		70	

electrical characteristics over recommended operating free-air temperature range (unless otherwise noted)

PARAMETER	TEST CONDITIONS†	MIN	TYP‡	MAX	UNIT
V_{IH} High-level input voltage		2			V
V_{IL} Low-level input voltage				0.8	V
V_{IK} Input clamp voltage	$V_{CC} = \text{MIN}$, $I_I = -18\text{mA}$			-1.2	V
I_{OH} High-level output current	$V_{CC} = \text{MIN}$, $V_{IH} = 2\text{V}$, $V_{IL} = 0.8\text{V}$			$V_{OH} = 2.4\text{V}$	50
				$V_{OH} = 5.5\text{V}$	100
V_{OL} Low-level output voltage	$V_{CC} = \text{MIN}$, $V_{IL} = 0.8\text{V}$, $V_{IH} = 2\text{V}$, $I_{OL} = \text{MAX}$			0.5	V
I_I Input current at maximum input voltage	$V_{CC} = \text{MAX}$, $V_I = 5.5\text{V}$			1	mA
I_{IH} High-level input current	$V_{CC} = \text{MAX}$, $V_I = 2.7\text{V}$			25	μA
I_{IL} Low-level input current	$V_{CC} = \text{MAX}$, $V_I = 0.5\text{V}$			-0.25	mA
I_{CC} Supply current	$V_{CC} = \text{MAX}$, Chip select(s) at 0 V, Outputs open, See Note 5		80	110	mA

switching characteristics over recommended ranges of T_A and V_{CC} (unless otherwise noted)

TYPE	TEST CONDITIONS	$t(A)$ ACCESS TIME FROM ADDRESS			$t_a(S)$ ACCESS TIME FROM CHIP SELECT (ENABLE TIME)			t_{PLH} PROPAGATION DELAY TIME, LOW-TO-HIGH-LEVEL OUTPUT FROM CHIP SELECT (DISABLE TIME)			UNIT
		MIN	TYP‡	MAX	MIN	TYP‡	MAX	MIN	TYP‡	MAX	
TBP18SA030MJ	$C_L = 30\text{pF}$, $R_{L1} = 300\ \Omega$,		25	50		12	30		12	30	ns
TBP18SA030	$R_{L2} = 600\ \Omega$, See Note 6		25	40		12	25		12	25	ns

†For conditions shown as MIN or MAX, use the appropriate value specified under recommended operating conditions.

‡All typical values are at $V_{CC} = 5\text{V}$, $T_A = 25^\circ\text{C}$.

NOTES: 4. MJ designates full-temperature circuits (formerly 54 Family), J and N designate commercial-temperature circuits (formerly 74 Family).

5. The typical values of I_{CC} are with all outputs low.

6. Load circuits and voltage waveforms are shown in Section 1.



PACKAGING INFORMATION

Orderable Device	Status ⁽¹⁾	Package Type	Package Drawing	Pins	Package Qty	Eco Plan ⁽²⁾	Lead/Ball Finish	MSL Peak Temp ⁽³⁾
JBP18S030MJ	NRND	CDIP	J	16	1	TBD	A42	N / A for Pkg Type

⁽¹⁾ The marketing status values are defined as follows:

ACTIVE: Product device recommended for new designs.

LIFEBUY: TI has announced that the device will be discontinued, and a lifetime-buy period is in effect.

NRND: Not recommended for new designs. Device is in production to support existing customers, but TI does not recommend using this part in a new design.

PREVIEW: Device has been announced but is not in production. Samples may or may not be available.

OBSOLETE: TI has discontinued the production of the device.

⁽²⁾ Eco Plan - The planned eco-friendly classification: Pb-Free (RoHS), Pb-Free (RoHS Exempt), or Green (RoHS & no Sb/Br) - please check <http://www.ti.com/productcontent> for the latest availability information and additional product content details.

TBD: The Pb-Free/Green conversion plan has not been defined.

Pb-Free (RoHS): TI's terms "Lead-Free" or "Pb-Free" mean semiconductor products that are compatible with the current RoHS requirements for all 6 substances, including the requirement that lead not exceed 0.1% by weight in homogeneous materials. Where designed to be soldered at high temperatures, TI Pb-Free products are suitable for use in specified lead-free processes.

Pb-Free (RoHS Exempt): This component has a RoHS exemption for either 1) lead-based flip-chip solder bumps used between the die and package, or 2) lead-based die adhesive used between the die and leadframe. The component is otherwise considered Pb-Free (RoHS compatible) as defined above.

Green (RoHS & no Sb/Br): TI defines "Green" to mean Pb-Free (RoHS compatible), and free of Bromine (Br) and Antimony (Sb) based flame retardants (Br or Sb do not exceed 0.1% by weight in homogeneous material)

⁽³⁾ MSL, Peak Temp. -- The Moisture Sensitivity Level rating according to the JEDEC industry standard classifications, and peak solder temperature.

Important Information and Disclaimer: The information provided on this page represents TI's knowledge and belief as of the date that it is provided. TI bases its knowledge and belief on information provided by third parties, and makes no representation or warranty as to the accuracy of such information. Efforts are underway to better integrate information from third parties. TI has taken and continues to take reasonable steps to provide representative and accurate information but may not have conducted destructive testing or chemical analysis on incoming materials and chemicals. TI and TI suppliers consider certain information to be proprietary, and thus CAS numbers and other limited information may not be available for release.

In no event shall TI's liability arising out of such information exceed the total purchase price of the TI part(s) at issue in this document sold by TI to Customer on an annual basis.

J (R-GDIP-T**)

14 LEADS SHOWN

CERAMIC DUAL IN-LINE PACKAGE



DIM \ PINS **	14	16	18	20
A	0.300 (7,62) BSC	0.300 (7,62) BSC	0.300 (7,62) BSC	0.300 (7,62) BSC
B MAX	0.785 (19,94)	.840 (21,34)	0.960 (24,38)	1.060 (26,92)
B MIN	—	—	—	—
C MAX	0.300 (7,62)	0.300 (7,62)	0.310 (7,87)	0.300 (7,62)
C MIN	0.245 (6,22)	0.245 (6,22)	0.220 (5,59)	0.245 (6,22)



4040083/F 03/03

- NOTES:
- All linear dimensions are in inches (millimeters).
 - This drawing is subject to change without notice.
 - This package is hermetically sealed with a ceramic lid using glass frit.
 - Index point is provided on cap for terminal identification only on press ceramic glass frit seal only.
 - Falls within MIL STD 1835 GDIP1-T14, GDIP1-T16, GDIP1-T18 and GDIP1-T20.

IMPORTANT NOTICE

Texas Instruments Incorporated and its subsidiaries (TI) reserve the right to make corrections, modifications, enhancements, improvements, and other changes to its products and services at any time and to discontinue any product or service without notice. Customers should obtain the latest relevant information before placing orders and should verify that such information is current and complete. All products are sold subject to TI's terms and conditions of sale supplied at the time of order acknowledgment.

TI warrants performance of its hardware products to the specifications applicable at the time of sale in accordance with TI's standard warranty. Testing and other quality control techniques are used to the extent TI deems necessary to support this warranty. Except where mandated by government requirements, testing of all parameters of each product is not necessarily performed.

TI assumes no liability for applications assistance or customer product design. Customers are responsible for their products and applications using TI components. To minimize the risks associated with customer products and applications, customers should provide adequate design and operating safeguards.

TI does not warrant or represent that any license, either express or implied, is granted under any TI patent right, copyright, mask work right, or other TI intellectual property right relating to any combination, machine, or process in which TI products or services are used. Information published by TI regarding third-party products or services does not constitute a license from TI to use such products or services or a warranty or endorsement thereof. Use of such information may require a license from a third party under the patents or other intellectual property of the third party, or a license from TI under the patents or other intellectual property of TI.

Reproduction of TI information in TI data books or data sheets is permissible only if reproduction is without alteration and is accompanied by all associated warranties, conditions, limitations, and notices. Reproduction of this information with alteration is an unfair and deceptive business practice. TI is not responsible or liable for such altered documentation. Information of third parties may be subject to additional restrictions.

Resale of TI products or services with statements different from or beyond the parameters stated by TI for that product or service voids all express and any implied warranties for the associated TI product or service and is an unfair and deceptive business practice. TI is not responsible or liable for any such statements.

TI products are not authorized for use in safety-critical applications (such as life support) where a failure of the TI product would reasonably be expected to cause severe personal injury or death, unless officers of the parties have executed an agreement specifically governing such use. Buyers represent that they have all necessary expertise in the safety and regulatory ramifications of their applications, and acknowledge and agree that they are solely responsible for all legal, regulatory and safety-related requirements concerning their products and any use of TI products in such safety-critical applications, notwithstanding any applications-related information or support that may be provided by TI. Further, Buyers must fully indemnify TI and its representatives against any damages arising out of the use of TI products in such safety-critical applications.

TI products are neither designed nor intended for use in military/aerospace applications or environments unless the TI products are specifically designated by TI as military-grade or "enhanced plastic." Only products designated by TI as military-grade meet military specifications. Buyers acknowledge and agree that any such use of TI products which TI has not designated as military-grade is solely at the Buyer's risk, and that they are solely responsible for compliance with all legal and regulatory requirements in connection with such use.

TI products are neither designed nor intended for use in automotive applications or environments unless the specific TI products are designated by TI as compliant with ISO/TS 16949 requirements. Buyers acknowledge and agree that, if they use any non-designated products in automotive applications, TI will not be responsible for any failure to meet such requirements.

Following are URLs where you can obtain information on other Texas Instruments products and application solutions:

Products

Amplifiers	amplifier.ti.com
Data Converters	dataconverter.ti.com
DLP® Products	www.dlp.com
DSP	dsp.ti.com
Clocks and Timers	www.ti.com/clocks
Interface	interface.ti.com
Logic	logic.ti.com
Power Mgmt	power.ti.com
Microcontrollers	microcontroller.ti.com
RFID	www.ti-rfid.com
RF/IF and ZigBee® Solutions	www.ti.com/lprf

Applications

Audio	www.ti.com/audio
Automotive	www.ti.com/automotive
Broadband	www.ti.com/broadband
Digital Control	www.ti.com/digitalcontrol
Medical	www.ti.com/medical
Military	www.ti.com/military
Optical Networking	www.ti.com/opticalnetwork
Security	www.ti.com/security
Telephony	www.ti.com/telephony
Video & Imaging	www.ti.com/video
Wireless	www.ti.com/wireless

Mailing Address: Texas Instruments, Post Office Box 655303, Dallas, Texas 75265
Copyright © 2009, Texas Instruments Incorporated