

TOSHIBA BIPOLAR LINEAR INTEGRATED CIRCUIT SILICON MONOLITHIC

TA8407P, TA8407F

DUAL POWER OPERATIONAL AMPLIFIER

The TA8407P, TA8407F are dual power operational amplifier. It is intended for use especially DC MOTOR positioning system applications, such as Arm Driver (for Audiodisk Players), head or voice coil motor drivers (for Floppy and Winchester Disk Drivers) and any other power driver applications.

FEATURES

- Built-in over current protector
- Few external parts are required.
- Output current up to 1.2 A Max. (AVE)
- Excellent crosstalk characteristics

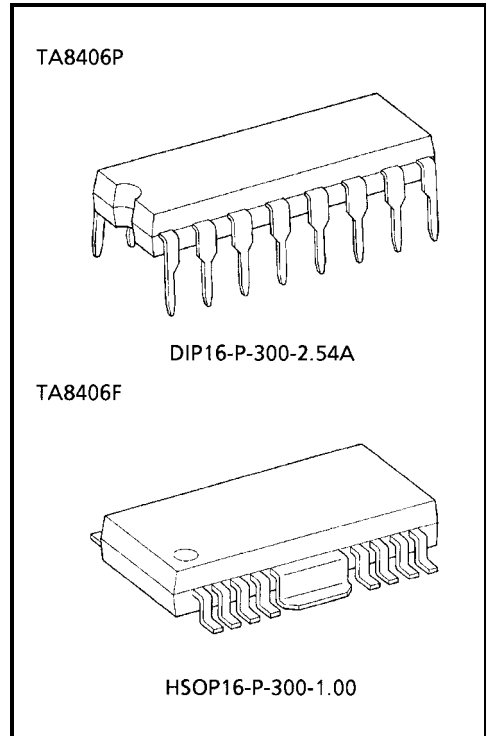

Weight:
 DIP16-P-300-2.54A : 1.0 g (Typ.)
 HSOP16-P-300-1.00 : 0.5 g (Typ.)

BLOCK DIAGRAM

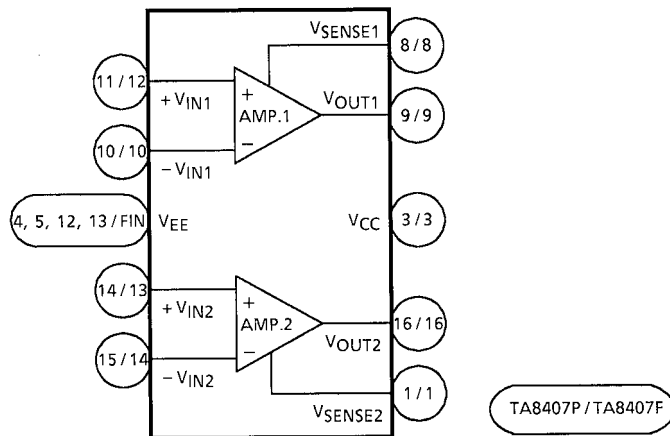

PIN FUNCTION

TA8407P

PIN No.	SYMBOL	FUNCTION DESCRIPTION
1	V _{SENSE2}	Amp.2 output current detection terminal.
2	NC	No connection.
3	V _{CC}	Positive-side power supply terminal.
4	V _{EE}	Negative-side power supply terminal.
5	V _{EE}	Negative-side power supply terminal.
6	NC	No connection.
7	NC	No connection.
8	V _{SENSE1}	Amp.1 output current detection terminal.
9	V _{OUT1}	Amp.1 output terminal.
10	-V _{IN1}	Amp.1 input terminal (-).
11	+V _{IN1}	Amp.1 input terminal (+).
12	V _{EE}	Negative-side power supply terminal.
13	V _{EE}	Negative-side power supply terminal.
14	+V _{IN2}	Amp.2 input terminal (+).
15	-V _{IN2}	Amp.2 input terminal (-).
16	V _{OUT2}	Amp.2 output terminal

TA8407F

PIN No.	SYMBOL	FUNCTION DESCRIPTION
1	V _{SENSE2}	AMP.2 output current detection terminal.
2	NC	No connection.
3	V _{CC}	Positive-side power supply terminal.
4	NC	No connection
5	NC	No connection
6	NC	No connection
7	NC	No connection
8	V _{SENSE1}	AMP.1 output current detection terminal.
9	V _{OUT1}	AMP.1 output terminal.
10	-V _{IN1}	AMP.1 input terminal (-).
11	NC	No connection.
12	+V _{IN1}	AMP.1 input terminal (+).
13	+V _{IN2}	AMP.2 input terminal (+).
14	-V _{IN2}	AMP.2 input terminal (-).
15	NC	No connection.
16	V _{OUT2}	AMP.2 output terminal.
FIN	V _{EE}	Negative-side power supply terminal.

MAXIMUM RATINGS (Ta = 25°C)

CHARACTERISTIC		SYMBOL	RATING	UNIT
Supply Voltage		V _{CC} , V _{EE}	±18	V
Output Current		I _O (AVE.)	1.2 (Note 1)	A
Power Dissipation	TA8407P	P _D	1.4 (Note 2)	W
			2.7 (Note 3)	
	TA8407P		1.4 (Note 4)	
Operating Temperature		T _{opr}	-30~75	°C
Storage Temperature		T _{stg}	-55~150	°C

Note 1: V_{CC} = 6 V, V_{EE} = -6 V

Note 2: No heat sink

Note 3: This value is obtained by 50 × 50 × 0.8 mm PCB mounting occupied in excess of 60% of copper area.

Note 4: This value is obtained by 60 × 30 × 1.6 mm PCB mounting occupied in excess of 50% of copper area.

ELECTRICAL CHARACTERISTICS

(Unless otherwise specified, V_{CC} = 15 V, V_{EE} = -15 V, Ta = 25°C)

CHARACTERISTIC		SYMBOL	TEST CIRCUIT	TEST CONDITION	MIN	TYP.	MAX	UNIT
Quiescent Current		I _{CC}	—	—	—	20	35	mA
Input Off Set Current		I _{IO}	—	—	—	2	100	nA
Input Bias Current		I _I	—	—	—	50	300	nA
Input Off Set Voltage		V _{IO}	—	—	—	1.0	7.0	mV
Output Voltage Swing	Upper	V _{OH}	—	V _{CC} = ±15 V, I _O = 1 A	11.5	12.1	—	V
	Lower	V _{OL}	—		-11.5	-12.3	—	
	Upper	V _{OH}	—	V _{CC} = ±6 V, I _O = 1 A	2.2	3.3	—	V
	Lower	V _{OL}	—		-2.2	-3.7	—	
Open Loop Gain		G _{VO}	—	—	—	90	—	dB
Input Common Mode Voltage Range		CMR	—	—	—	±14	—	
Common Mode Rejection Ratio		CMRR	—	—	—	95	—	dB
Supply Voltage Rejection Ratio		SVRR	—	—	—	45	150	μV / V
Slew Rate		SR	—	—	—	0.4	—	V / μs
Short Circuit Current		I _{SC}	—	R _{SC} = 0.68 Ω	0.8	1.0	—	A
Cross Talk		CT	—	—	—	60	—	dB

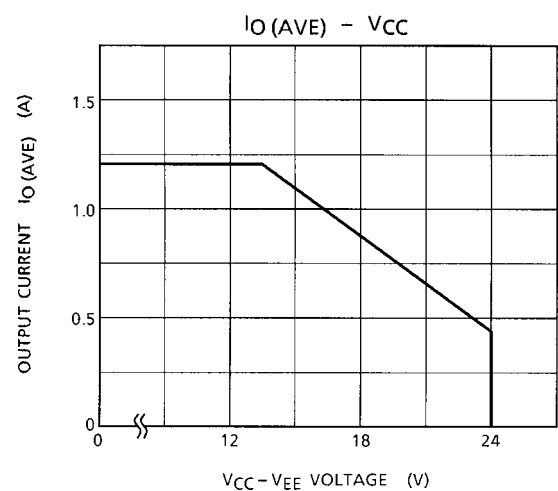
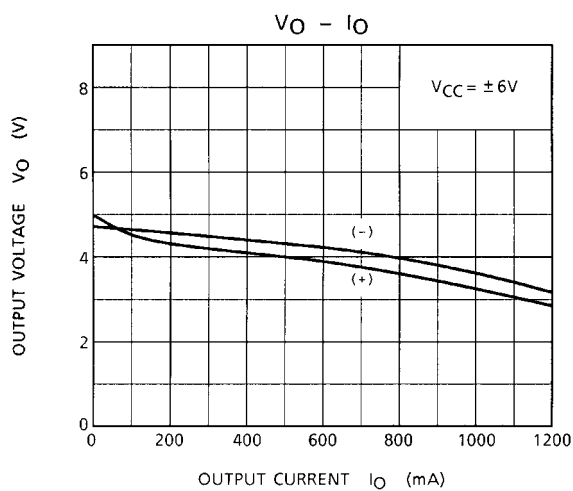
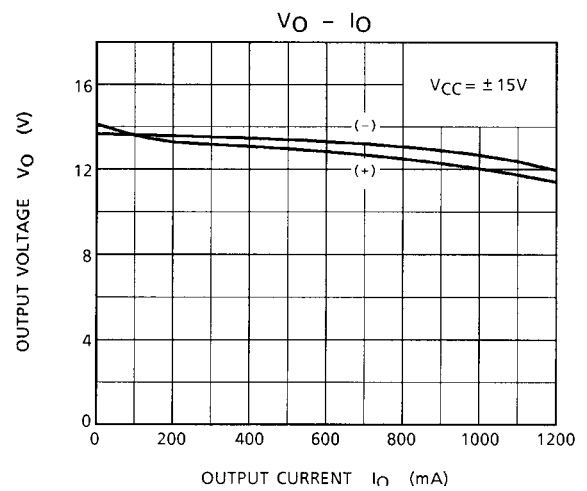
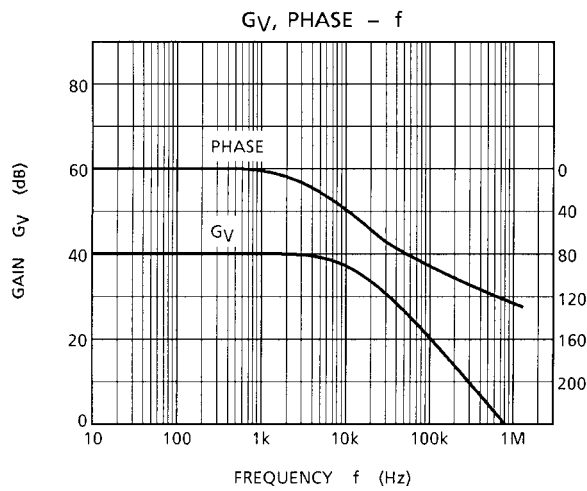
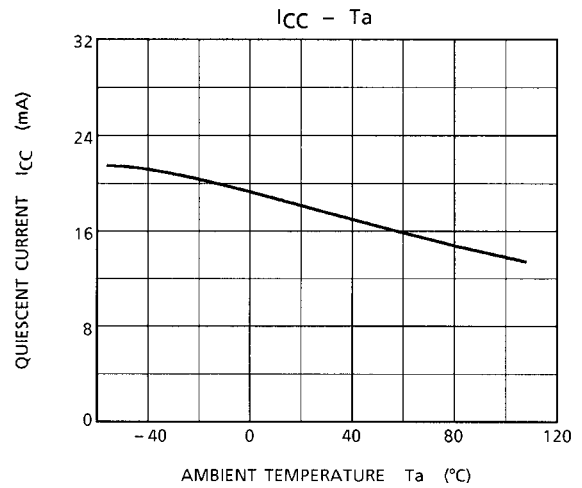
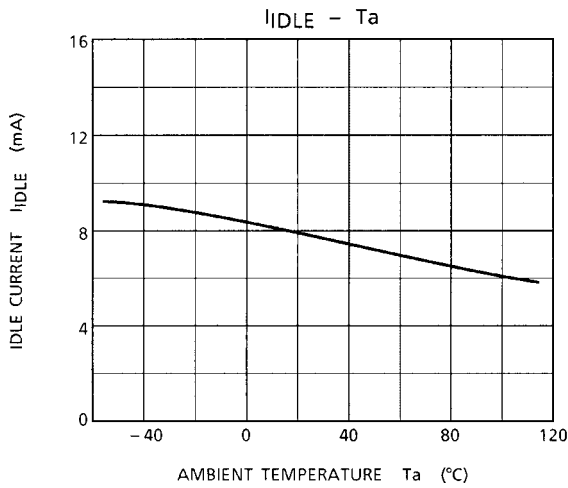

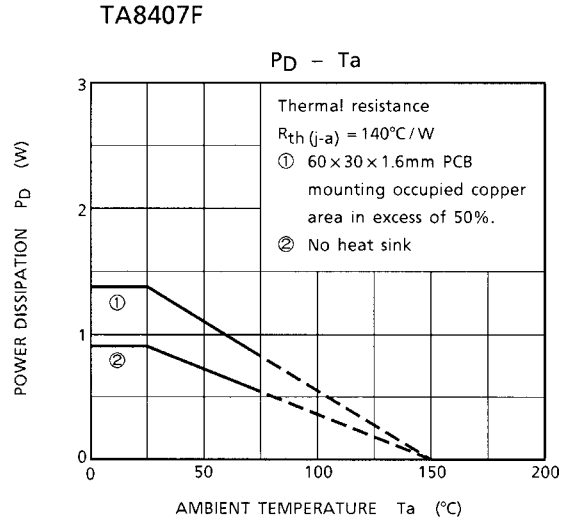
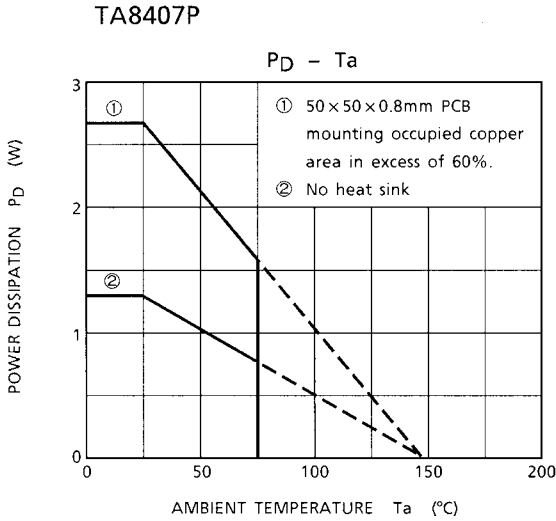

APPLICATION CIRCUIT 1.

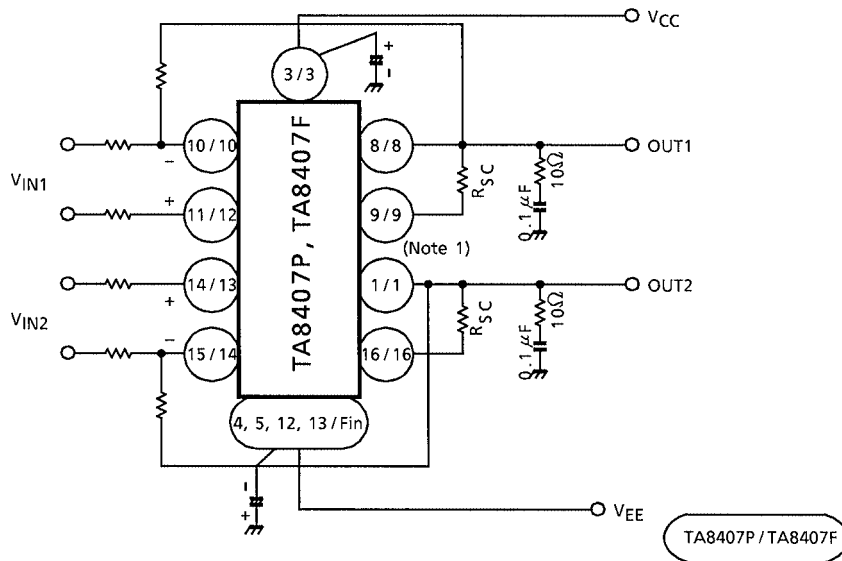

Note 1: $I_{SC} \approx \frac{0.7(V)}{R_{SC}(\Omega)} (A)$

Note 2: If crosstalk is recognizable remarkably in applications above 80 kHz, change a capacitor to one having a value of about 0.33 μF as a compensating circuit. Further, no resistor is needed in this case.

Note 3: Utmost care is necessary in the design of the output line, V_{CC} and GND line since IC may be destroyed due to short-circuit between outputs, air contamination fault, or fault by improper grounding.

APPLICATION CIRCUIT 2. (Actuator)

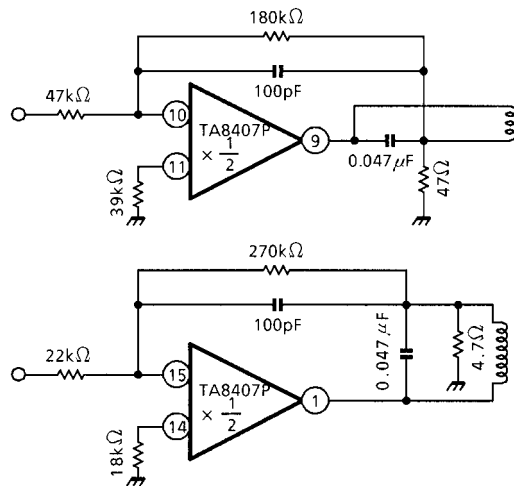

APPLICATION CIRCUIT 3. (Speed and carriage control)

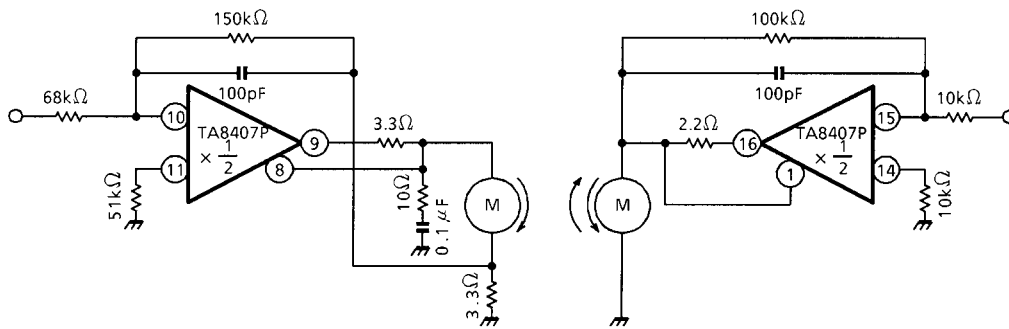

PACKAGE DIMENSIONS

DIP16-P-300-2.54A

Unit: mm

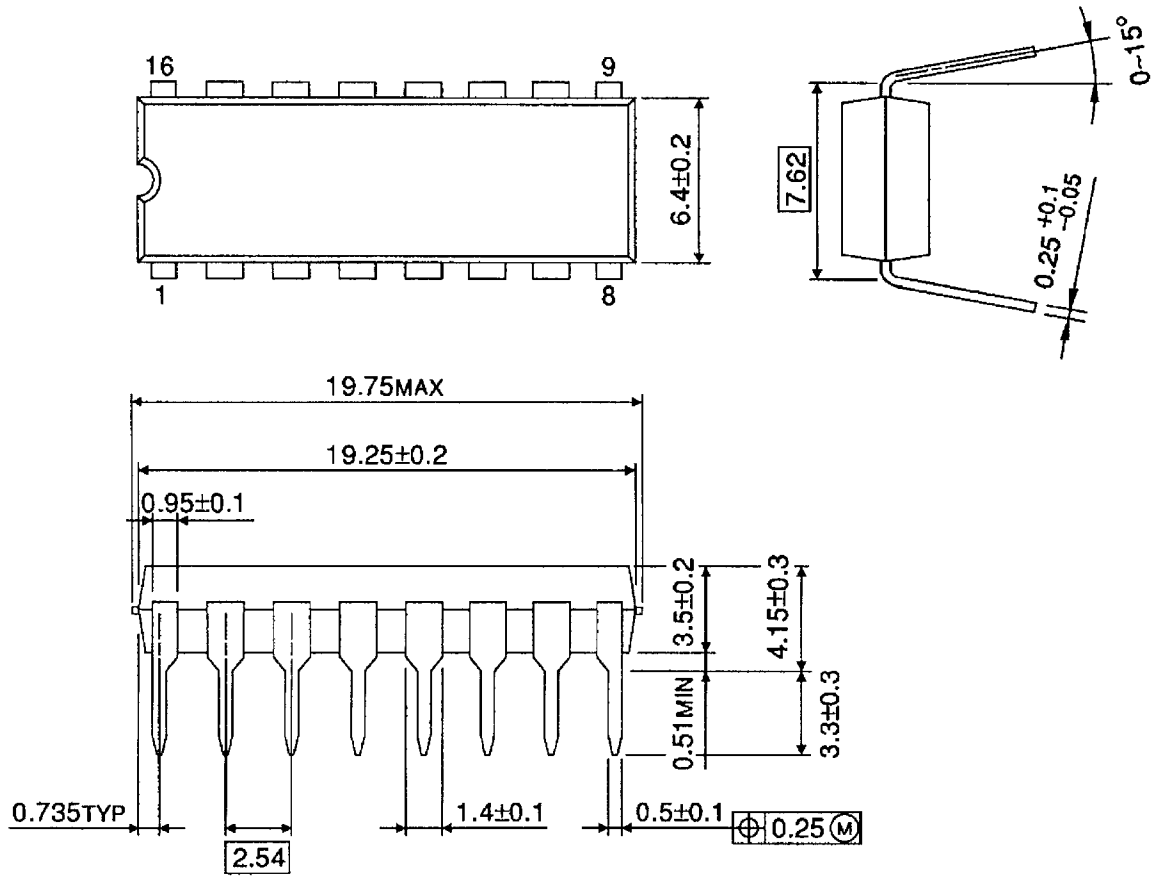

Weight: 1.0 g (Typ.)

PACKAGE DIMENSIONS

HSOP16-P-300-1.00

Unit: mm

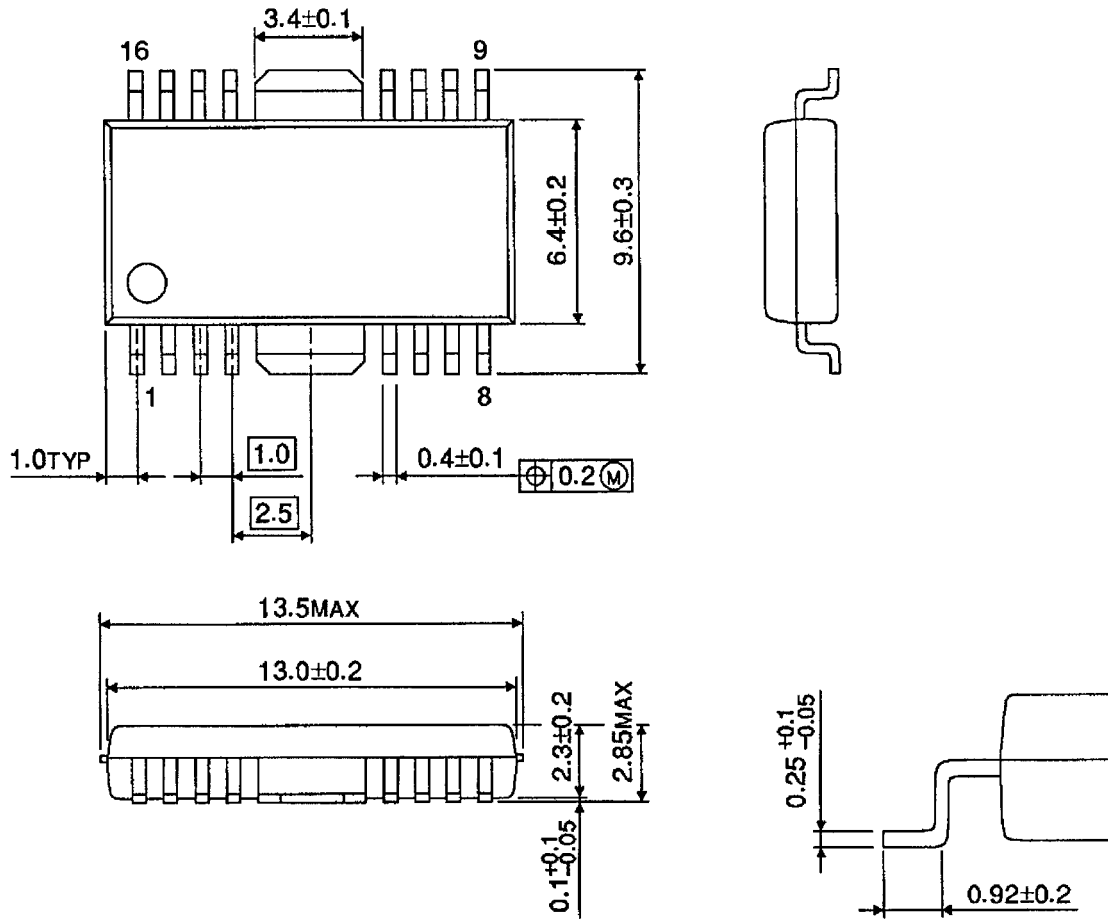

Weight: 0.50 g (Typ.)

RESTRICTIONS ON PRODUCT USE

000707EBA

- TOSHIBA is continually working to improve the quality and reliability of its products. Nevertheless, semiconductor devices in general can malfunction or fail due to their inherent electrical sensitivity and vulnerability to physical stress. It is the responsibility of the buyer, when utilizing TOSHIBA products, to comply with the standards of safety in making a safe design for the entire system, and to avoid situations in which a malfunction or failure of such TOSHIBA products could cause loss of human life, bodily injury or damage to property.
In developing your designs, please ensure that TOSHIBA products are used within specified operating ranges as set forth in the most recent TOSHIBA products specifications. Also, please keep in mind the precautions and conditions set forth in the "Handling Guide for Semiconductor Devices," or "TOSHIBA Semiconductor Reliability Handbook" etc..
- The TOSHIBA products listed in this document are intended for usage in general electronics applications (computer, personal equipment, office equipment, measuring equipment, industrial robotics, domestic appliances, etc.). These TOSHIBA products are neither intended nor warranted for usage in equipment that requires extraordinarily high quality and/or reliability or a malfunction or failure of which may cause loss of human life or bodily injury ("Unintended Usage"). Unintended Usage include atomic energy control instruments, airplane or spaceship instruments, transportation instruments, traffic signal instruments, combustion control instruments, medical instruments, all types of safety devices, etc.. Unintended Usage of TOSHIBA products listed in this document shall be made at the customer's own risk.
- The products described in this document are subject to the foreign exchange and foreign trade laws.
- The information contained herein is presented only as a guide for the applications of our products. No responsibility is assumed by TOSHIBA CORPORATION for any infringements of intellectual property or other rights of the third parties which may result from its use. No license is granted by implication or otherwise under any intellectual property or other rights of TOSHIBA CORPORATION or others.
- The information contained herein is subject to change without notice.