

SN74ALS155 DUAL 2-LINE TO 4-LINE DECODER/DEMULTIPLEXER

SDAS140 — NOVEMBER 1987

- **Applications:**
 - Dual 2-Line to 4-Line Decoder
 - Dual 1-Line to 4-Line Demultiplexer
 - 3-Line to 8-Line Decoder
 - 1-Line to 8-Line Demultiplexer
- **Individual Strobes Simplify Cascading For Decoding or Demultiplexing Larger Words**
- **Package Options Include Plastic "Small Outline" Packages and Standard Plastic 300-mil DIPs**

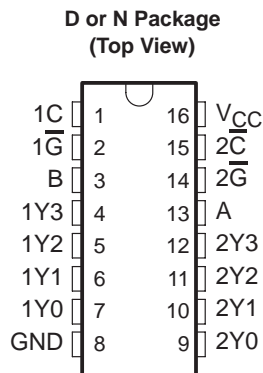

description

The 'ALS155 circuits feature dual 1-line to 4-line demultiplexers with individual strobes and common binary-address inputs in a single 16-pin package. When both sections are enabled, the common binary-address inputs sequentially select and route associated input data to the appropriate output of each section. The individual strobes permit enabling or disabling each of the 4-bit sections as desired.

Data applied to input 1C is inverted at its outputs and data applied at input 2C is not inverted through its outputs. The inverter following the 1C data input permits use of the 'ALS155 as a 3-line to 8-line demultiplexer without external gating. All inputs are clamped with high-performance Schottky diodes to suppress line ringing and simplify system design.

The SN74ALS155 is characterized for operation from 0°C to 70°C.

logic diagram (positive logic)

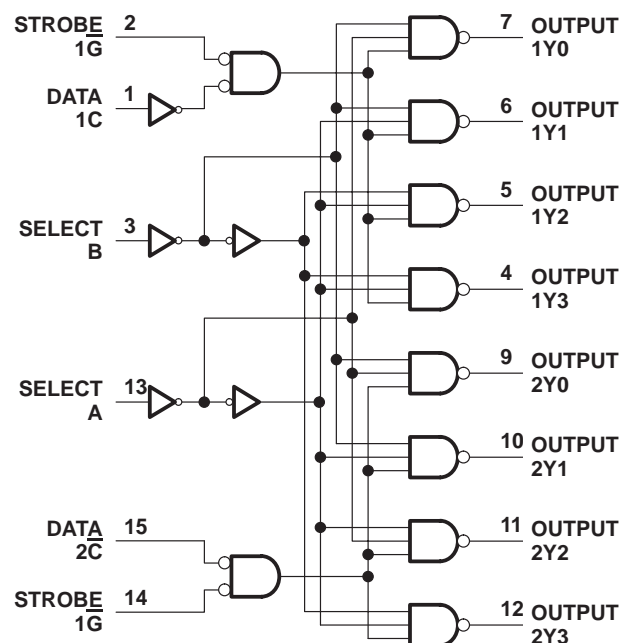

SN74ALS155 DUAL 2-LINE TO 4-LINE DECODER/DEMULTIPLEXER

SDAS140 — NOVEMBER 1987

logic symbols† (alternatives)

2-LINE TO 4-LINE DECODER

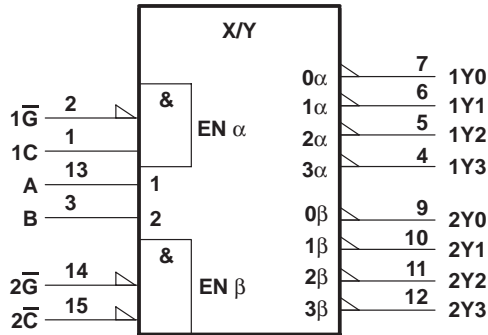

1-LINE TO 4-LINE DEMULTIPLEXER

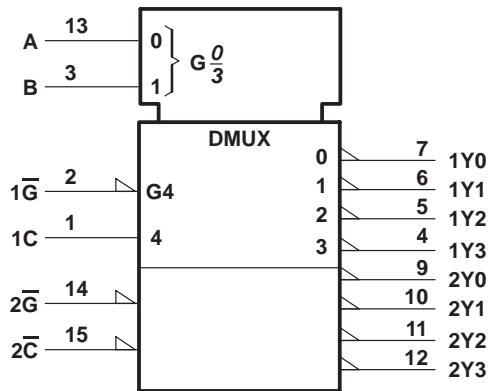

3-LINE TO 8-LINE DECODER

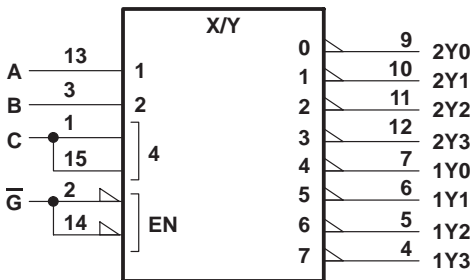

1-LINE TO 8-LINE DEMULTIPLEXER

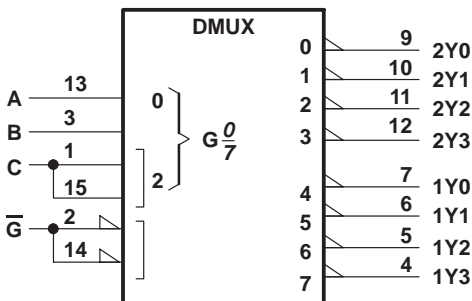

FUNCTION TABLE
2-LINE TO 4-LINE DECODER
OR
1-LINE TO 4-LINE DEMULTIPLEXER

| INPUTS | | | OUTPUTS | | | | |
|--------|---|--------------|------------|-----|-----|-----|-----|
| SELECT | | STROBE 1G | DATA 1C | 1Y0 | 1Y1 | 1Y2 | 1Y3 |
| B | A | | | | | | |
| X | X | H | X | H | H | H | H |
| L | L | L | H | L | H | H | H |
| L | H | L | H | H | L | H | H |
| H | L | L | H | H | H | L | H |
| H | H | L | H | H | H | H | L |
| X | X | X | L | H | H | H | H |

| INPUTS | | | OUTPUTS | | | | |
|--------|---|--------------|------------|-----|-----|-----|-----|
| SELECT | | STROBE 2G | DATA 2C | 2Y0 | 2Y1 | 2Y2 | 2Y3 |
| B | A | | | | | | |
| X | X | H | X | H | H | H | H |
| L | L | L | L | L | H | H | H |
| L | H | L | L | H | L | H | H |
| H | L | L | L | H | H | L | H |
| H | H | L | L | H | H | H | L |
| X | X | X | H | H | H | H | H |

FUNCTION TABLE
3-LINE TO 8-LINE DECODER
OR
1-LINE TO 8-LINE DEMULTIPLEXER

| INPUTS | | | | OUTPUTS | | | | | | | |
|--------|---|---|------------------------|---------|-----|-----|-----|-----|-----|-----|-----|
| SELECT | | | STROBE OR DATA G | (0) | (1) | (2) | (3) | (4) | (5) | (6) | (7) |
| C‡ | B | A | | 2Y0 | 2Y1 | 2Y2 | 2Y3 | 1Y0 | 1Y1 | 1Y2 | 1Y3 |
| X | X | X | H | H | H | H | H | H | H | H | H |
| L | L | L | L | L | H | H | H | H | H | H | H |
| L | L | H | L | H | L | H | H | H | H | H | H |
| L | H | L | L | H | H | L | H | H | H | H | H |
| L | H | H | L | H | H | H | L | H | H | H | H |
| H | L | L | L | H | H | H | H | L | H | H | H |
| H | L | H | L | H | H | H | H | H | L | H | H |
| H | H | L | L | H | H | H | H | H | H | L | H |
| H | H | H | L | H | H | H | H | H | H | H | L |

‡ C = inputs 1C and 2C connected together
§ G = inputs 1G and 2G connected together

† These symbols are in accordance with ANSI/IEEE Std 91-1984 and IEC Publication 617-12.



SN74ALS155 DUAL 2-LINE TO 4-LINE DECODER/DEMULTIPLEXER

SDAS140 — NOVEMBER 1987

absolute maximum ratings over operating free-air temperature range (unless otherwise noted)[†]

| | |
|---|-----------------|
| Supply voltage, V_{CC} (see Note 1) | 7 V |
| Input voltage | 7 V |
| Operating free-air temperature range | 0°C to 70°C |
| Storage temperature range | – 65°C to 150°C |

[†] Stresses beyond those listed under "Absolute Maximum Ratings" may cause permanent damage to the device. This is a stress rating only, and functional operation of the device at these or any other conditions beyond those indicated in the "Recommended Operating Conditions" section of this specification is not implied. Exposure to absolute-maximum-rated conditions for extended periods may affect device reliability.

NOTE 1: All voltage values are with respect to GND.

recommended operating conditions

| | MIN | NOM | MAX | UNIT |
|--------------------------------------|-----|-----|-------|------|
| V_{CC} Supply voltage | 4.5 | 5 | 5.5 | V |
| V_{IH} High-level input voltage | 2 | | | V |
| V_{IL} Low-level input voltage | | | 0.8 | V |
| I_{OH} High-level output current | | | – 0.4 | mA |
| I_{OL} Low-level output current | | | 8 | mA |
| T_A Operating free-air temperature | 0 | | 70 | °C |

electrical characteristics over recommended free-air temperature range (unless otherwise noted)

| PARAMETER | TEST CONDITIONS | MIN | TYP [†] | MAX | UNIT |
|-----------|---|--------------|------------------|-------|------|
| V_{IK} | $V_{CC} = 4.5$ V, $I_I = -18$ mA | | | – 1.5 | V |
| V_{OH} | $V_{CC} = 4.5$ V to 5.5 V, $I_{OH} = -0.4$ mA | $V_{CC} - 2$ | | | V |
| V_{OL} | $V_{CC} = 4.5$ V, $I_{OL} = 8$ mA | | 0.35 | 0.5 | V |
| I_I | $V_{CC} = 5.5$ V, $V_I = 7$ V | | | 0.1 | mA |
| I_{IH} | $V_{CC} = 5.5$ V, $V_I = 2.7$ V | | | 20 | μA |
| I_L | $V_{CC} = 5.5$ V, $V_I = 0.4$ V | | | – 0.1 | μA |
| I_{CCL} | $V_{CC} = 5.5$ V, | | 7 | 13 | mA |

[†] All typical value are at $V_{CC} = 5$ V, $T_A = 25$ °C.

switching characteristics over recommended ranges of supply voltage and operating free-air temperature (see Note 2)

| PARAMETER | FROM (INPUT) | TO (OUTPUT) | $V_{CC} = 4.5$ V to 5.5 V, $C_L = 50$ pF, $R_L = 500$ Ω, $T_A = 0$ °C to 70°C | | UNIT |
|-----------|----------------------|-------------|--|-----|------|
| | | | MIN | MAX | |
| t_{PLH} | A, B | 1Y, 2Y | 3 | 14 | ns |
| t_{PHL} | | | 3 | 12 | |
| t_{PLH} | 1C | 1Y | 3 | 12 | ns |
| t_{PHL} | | | 3 | 14 | |
| t_{PLH} | $1\bar{G}$ | 1Y | 3 | 12 | ns |
| t_{PHL} | | | 3 | 13 | |
| t_{PLH} | $2\bar{C}, 2\bar{G}$ | 2Y | 3 | 12 | ns |
| t_{PHL} | | | 3 | 14 | |

NOTE 2: Load circuits and voltage waveforms are shown in Section 1, *ALS/AS Logic Data Book*, 1986.



IMPORTANT NOTICE

Texas Instruments Incorporated and its subsidiaries (TI) reserve the right to make corrections, modifications, enhancements, improvements, and other changes to its products and services at any time and to discontinue any product or service without notice. Customers should obtain the latest relevant information before placing orders and should verify that such information is current and complete. All products are sold subject to TI's terms and conditions of sale supplied at the time of order acknowledgment.

TI warrants performance of its hardware products to the specifications applicable at the time of sale in accordance with TI's standard warranty. Testing and other quality control techniques are used to the extent TI deems necessary to support this warranty. Except where mandated by government requirements, testing of all parameters of each product is not necessarily performed.

TI assumes no liability for applications assistance or customer product design. Customers are responsible for their products and applications using TI components. To minimize the risks associated with customer products and applications, customers should provide adequate design and operating safeguards.

TI does not warrant or represent that any license, either express or implied, is granted under any TI patent right, copyright, mask work right, or other TI intellectual property right relating to any combination, machine, or process in which TI products or services are used. Information published by TI regarding third-party products or services does not constitute a license from TI to use such products or services or a warranty or endorsement thereof. Use of such information may require a license from a third party under the patents or other intellectual property of the third party, or a license from TI under the patents or other intellectual property of TI.

Reproduction of TI information in TI data books or data sheets is permissible only if reproduction is without alteration and is accompanied by all associated warranties, conditions, limitations, and notices. Reproduction of this information with alteration is an unfair and deceptive business practice. TI is not responsible or liable for such altered documentation. Information of third parties may be subject to additional restrictions.

Resale of TI products or services with statements different from or beyond the parameters stated by TI for that product or service voids all express and any implied warranties for the associated TI product or service and is an unfair and deceptive business practice. TI is not responsible or liable for any such statements.

TI products are not authorized for use in safety-critical applications (such as life support) where a failure of the TI product would reasonably be expected to cause severe personal injury or death, unless officers of the parties have executed an agreement specifically governing such use. Buyers represent that they have all necessary expertise in the safety and regulatory ramifications of their applications, and acknowledge and agree that they are solely responsible for all legal, regulatory and safety-related requirements concerning their products and any use of TI products in such safety-critical applications, notwithstanding any applications-related information or support that may be provided by TI. Further, Buyers must fully indemnify TI and its representatives against any damages arising out of the use of TI products in such safety-critical applications.

TI products are neither designed nor intended for use in military/aerospace applications or environments unless the TI products are specifically designated by TI as military-grade or "enhanced plastic." Only products designated by TI as military-grade meet military specifications. Buyers acknowledge and agree that any such use of TI products which TI has not designated as military-grade is solely at the Buyer's risk, and that they are solely responsible for compliance with all legal and regulatory requirements in connection with such use.

TI products are neither designed nor intended for use in automotive applications or environments unless the specific TI products are designated by TI as compliant with ISO/TS 16949 requirements. Buyers acknowledge and agree that, if they use any non-designated products in automotive applications, TI will not be responsible for any failure to meet such requirements.

Following are URLs where you can obtain information on other Texas Instruments products and application solutions:

Products

| | |
|-----------------------------|--|
| Amplifiers | amplifier.ti.com |
| Data Converters | dataconverter.ti.com |
| DSP | dsp.ti.com |
| Clocks and Timers | www.ti.com/clocks |
| Interface | interface.ti.com |
| Logic | logic.ti.com |
| Power Mgmt | power.ti.com |
| Microcontrollers | microcontroller.ti.com |
| RFID | www.ti-rfid.com |
| RF/IF and ZigBee® Solutions | www.ti.com/lprf |

Applications

| | |
|--------------------|--|
| Audio | www.ti.com/audio |
| Automotive | www.ti.com/automotive |
| Broadband | www.ti.com/broadband |
| Digital Control | www.ti.com/digitalcontrol |
| Medical | www.ti.com/medical |
| Military | www.ti.com/military |
| Optical Networking | www.ti.com/opticalnetwork |
| Security | www.ti.com/security |
| Telephony | www.ti.com/telephony |
| Video & Imaging | www.ti.com/video |
| Wireless | www.ti.com/wireless |

Mailing Address: Texas Instruments, Post Office Box 655303, Dallas, Texas 75265
Copyright © 2008, Texas Instruments Incorporated