

TYPE SN74351 DUAL DATA SELECTOR/MULTIPLEXER WITH 3-STATE OUTPUTS

MARCH 1974 — REVISED DECEMBER 1983

- Dual 8-Line-to-1-Line Multiplexer That Can Replace Two SN54151, SN74151 Multiplexers in Some Applications
- Four Common Data Lines Permit Simultaneous Interdigitation with Parallel-to-Serial Conversion
- 4-Bit Organization Is Easily Adapted to Handle Binary or BCD
- Three-State Outputs Can Be Connected Directly to System Bus Lines
- Enable Input Controls Impedance Levels of the 12 Data Inputs and Two Outputs

SN74351 . . . J OR N PACKAGE

(TOP VIEW)

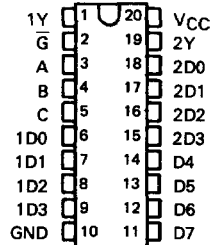

description

The SN74351 comprises two 8-line-to-1-line data selectors/multiplexers with full decoding on one monolithic chip. Symmetrically switching, complementary decode generators minimize decoder skew during changes at the select inputs and ensure that potentially erroneous effects are minimized at the data outputs. Four data inputs are exclusive to each multiplexer and four are common to both. A common enable input is provided which, when high, causes both outputs to assume the high-impedance (off) state and simultaneously diverts the majority of the input current, which reduces the load significantly on the data input drivers. A low logic level at the enable input activates both outputs so that each will assume the complement of the level of the selected input.

FUNCTION TABLE

INPUTS				OUTPUTS	
ENABLE	SELECT			1Y	2Y
\bar{G}	C	B	A	$\overline{1D0}$	$\overline{2D0}$
H	X	X	X	Z	Z
L	L	L	L	$\overline{1D0}$	$\overline{2D0}$
L	L	L	H	$\overline{1D1}$	$\overline{2D1}$
L	L	H	L	$\overline{1D2}$	$\overline{2D2}$
L	L	H	H	$\overline{1D3}$	$\overline{2D3}$
L	H	L	L	$\overline{D4}$	$\overline{D4}$
L	H	L	H	$\overline{D5}$	$\overline{D5}$
L	H	H	L	$\overline{D6}$	$\overline{D6}$
L	H	H	H	$\overline{D7}$	$\overline{D7}$

H = high level, L = low level, X = irrelevant
 Z = high impedance (off)
 $\overline{1D0}, \overline{1D1}, \dots, \overline{D7}$ = The complement of the level of the respective D input

3

TTL DEVICES

PRODUCTION DATA
 This document contains information current as of publication date. Products conform to these specifications per the terms of Texas Instruments standard warranty. Production processing does not necessarily include testing of all parameters.



POST OFFICE BOX 225012 • DALLAS, TEXAS 75265

3-991

**TYPE SN74351
DUAL DATA SELECTOR/MULTIPLEXER WITH 3-STATE OUTPUTS**

logic diagram

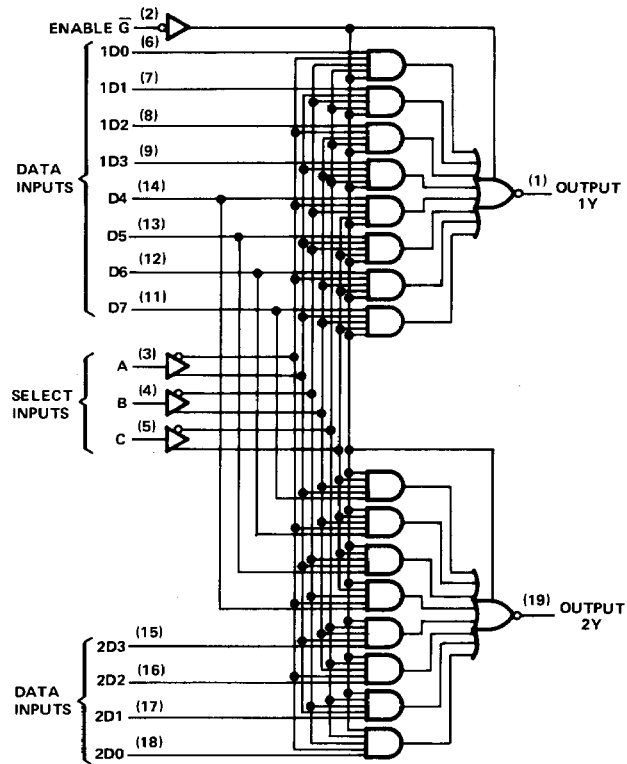

Pin numbers shown on logic notation are for J or N packages.

3

TTL DEVICES

schematics of inputs and outputs

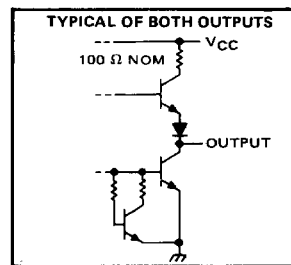
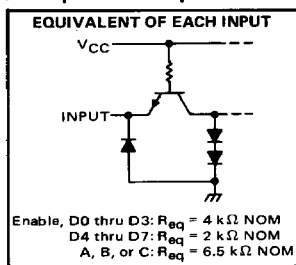

TYPE SN74351
DUAL DATA SELECTOR/MULTIPLEXER WITH 3-STATE OUTPUTS

absolute maximum ratings over operating free-air temperature range (unless otherwise noted)

Supply voltage, V_{CC} (see Note 1)	7 V
Input voltage	5.5 V
Operating free-air temperature	0°C to 70°C
Storage temperature range	-65°C to 150°C

NOTE 1: Voltage values are with respect to network ground terminal.

recommended operating conditions

	MIN	NOM	MAX	UNIT
V_{CC} Supply voltage	4.75	5	5.25	V
I_{OH} High-level output current			-0.8	mA
I_{OL} Low-level output current			16	mA
T_A Operating free-air temperature	0		70	°C

electrical characteristics over recommended operating free-air temperature range (unless otherwise noted)

PARAMETER		TEST CONDITIONS [†]	MIN	TYP [‡]	MAX	UNIT
V_{IH}	High-level input voltage		2			V
V_{IL}	Low-level input voltage				0.8	V
V_{IK}	Input clamp voltage	$V_{CC} = \text{MIN}, I_I = -12 \text{ mA}$			-1.5	V
V_{OH}	High-level output voltage	$V_{CC} = \text{MIN}, V_{IH} = 2 \text{ V}, V_{IL} = 0.8 \text{ V}, I_{OH} = -0.8 \text{ mA}$	2.4	3.4		V
V_{OL}	Low-level output voltage	$V_{CC} = \text{MIN}, V_{IH} = 2 \text{ V}, V_{IL} = 0.8 \text{ V}, I_{OL} = 16 \text{ mA}$		0.2	0.4	V
I_{OZH}	Off-state output current, high-level voltage applied	$V_{CC} = \text{MAX}, V_{IH} = 2 \text{ V}, V_O = 2.4 \text{ V}$			40	μA
I_{OZL}	Off state output current, low level voltage applied	$V_{CC} = \text{MAX}, V_{IH} = 2 \text{ V}, V_O = 0.4 \text{ V}$			-40	μA
I_I	Input current at maximum input voltage	$V_{CC} = \text{MAX}, V_I = 5.5 \text{ V}$			1	mA
I_{IH}	High-level input current	Enable, any select, any D0 thru D3	$V_{CC} = \text{MAX}, V_I = 2.4 \text{ V}$		40	μA
		D4 thru D7			80	
I_{IL}	Low-level input current	Enable, any select, any D0 thru D3	$V_{CC} = \text{MAX}, V_I = 0.4 \text{ V}$		-1.6	mA
		D4 thru D7			-3.2	
		Any D		$V_{CC} = \text{MAX}, V_I = 0.5, V_{I(\text{enable})} = 2 \text{ V}$		-40
I_{OS}	Short-circuit output current [§]	$V_{CC} = \text{MAX}$	-18		-55	mA
I_{CC}	Supply current	$V_{CC} = \text{MAX},$ See Note 2		44	66	mA

[†]For conditions shown as MIN or MAX, use the appropriate value specified under recommended operating conditions.

[‡]All typical values are at $V_{CC} = 5 \text{ V}, T_A = 25^\circ\text{C}$.

[§]Not more than one output should be shorted at a time.

NOTE 2: I_{CC} is measured with the enable input grounded, other inputs and both outputs open.

3
TTL DEVICES

TYPE SN74351
DUAL DATA SELECTOR/MULTIPLEXER WITH 3-STATE OUTPUTS

switching characteristics, $V_{CC} = 5\text{ V}$, $T_A = 25^\circ\text{C}$

PARAMETER [†]	FROM (INPUT)	TO (OUTPUT)	TEST CONDITIONS	MIN	TYP	MAX	UNIT
t_{PLH}	A, B, or C	Y	$C_L = 50\text{ pF}$, $R_L = 400\ \Omega$, See Note 3		20	30	ns
t_{PHL}				20	30		
t_{PLH}	Any D	Y		10	22	ns	
t_{PHL}				10	22		
t_{PZH}	\bar{G}	Y		18	33	ns	
t_{PZL}				20	33		
t_{PHZ}	\bar{G}	Y	$C_L = 5\text{ pF}$, $R_L = 400\ \Omega$, See Note 3	6	20	ns	
t_{PLZ}			10	20			

NOTE 3: See General Information Section for load circuits and voltage waveforms.

TYPICAL APPLICATION DATA

This application illustrates how common data can be interdigitated onto two serial data lines. It is useful for transmitting prefixes, suffixes, addresses, or similar functions.

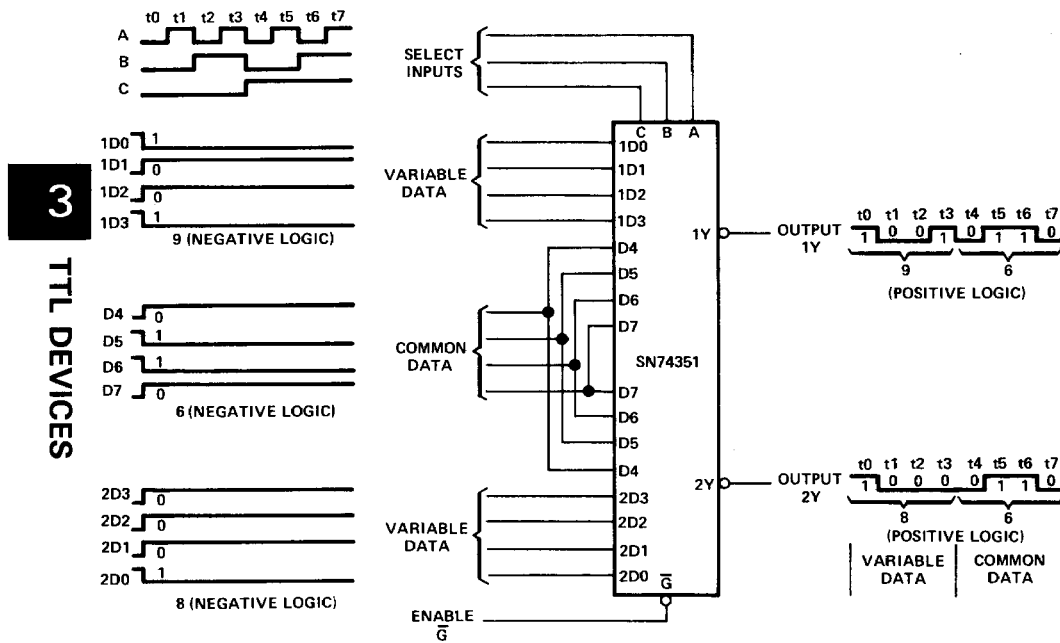

C

TTL DEVICES