

## DeviceNet™ CAN Transceivers

Check for Samples: [SN65HVD252](#), [SN65HVD253](#)

### FEATURES

- DeviceNet Compliant Supporting 64 DeviceNet Nodes
- Loopback Function (HVD253)
- Bus-Fault Protection of –36 V to 40 V
- Power-Up/Down Glitch-Free Bus I/O
- 3.3-V Compatible Receiver Output

### APPLICATIONS

- DeviceNet Networks (Vendor ID # 806)
- Industrial Automation
- HVAC Networks
- Security Systems
- Telecom Base Station Status and Control
- CANopen Data Bus
- SDS Data Bus
- CAN Kingdom Data Bus

### DESCRIPTION

The SN65HVD252 and SN65HVD253 CAN transceivers meet or exceed the specifications of DeviceNet and are compatible to the ISO 11898-2:2003 standard for use in applications employing a controller area network (CAN). This device provides differential transmit and receive capability at signaling rates up to 1 megabit per second (Mbps).

Designed for operation in harsh industrial environments, these devices feature bus-pin voltage protection from –36 V to 40 V, driver output current limiting, and overtemperature driver shutdown.

Pin 8 provides for two different modes of operation: normal and silent mode. The normal mode of operation is selected by connecting S (pin 8) to ground. If a high logic level is applied to the S pin, the device enters a listen-only silent mode during which the driver is inactive while the receiver remains fully functional.

The Vref pin 5 of the SN65HVD252 is a  $V_{CC}/2$  voltage reference for systems which use split termination.

The AB pin of the SN65HVD253 implements a listen-only loopback feature which allows the local node controller to synchronize its baud rate with that of the CAN bus. In loopback mode, the driver differential outputs are placed in high-impedance state while the receiver bus inputs remain active. For more information on the loopback mode, see the [Application Information](#) section.

The SN65HVD252 and SN65HVD253 are characterized for operation from –40°C to 85°C.

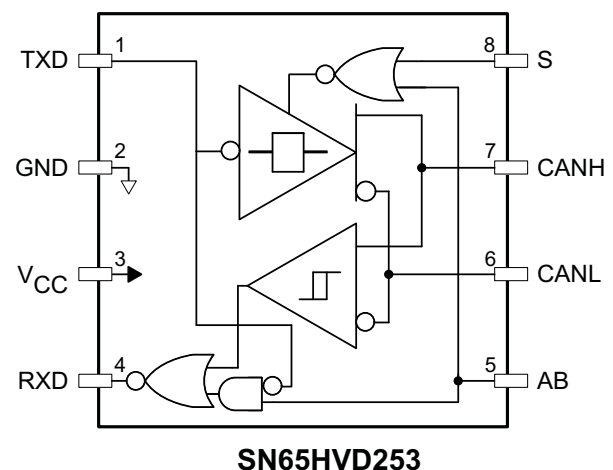
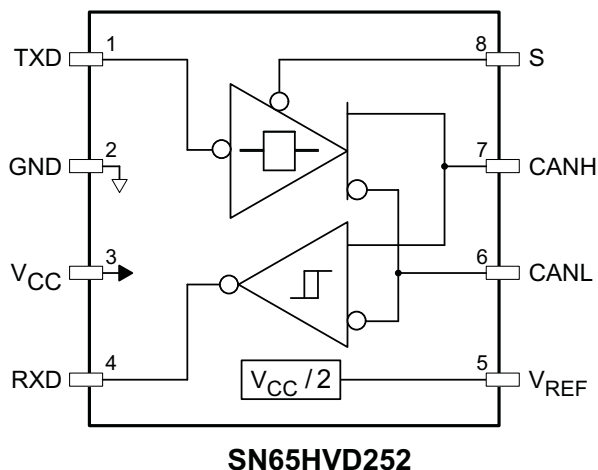

Please be aware that an important notice concerning availability, standard warranty, and use in critical applications of Texas Instruments semiconductor products and disclaimers thereto appears at the end of this data sheet.

DeviceNet is a trademark of Open DeviceNet Vendor Association .



These devices have limited built-in ESD protection. The leads should be shorted together or the device placed in conductive foam during storage or handling to prevent electrostatic damage to the MOS gates.



Table 1. DRIVER (SN65HVD252)

INPUTS		OUTPUTS		BUS STATE
TXD	S	CAN_H	CAN_L	
L	L or OPEN	H	L	Dominant
H or OPEN		Z	Z	Recessive
X	H	Z	Z	Recessive

Table 2. RECEIVER (SN65HVD252)

INPUTS		OUTPUT
BUS STATE	$V_{ID} = V_{CANH} - V_{CANL}$	RXD
Dominant	$V_{ID} \geq 0.9 V$	L
?	$0.5 V < V_{ID} < 0.9 V$	?
Recessive	$V_{ID} < 0.5 V$	H
OPEN	$V_{ID} \approx 0 V$	H

Table 3. DRIVER (SN65HVD253)

INPUTS			OUTPUTS		BUS STATE
TXD	AB	S	CAN_H	CAN_L	
X	X	H	Z	Z	Recessive
L	L or open	L or OPEN	H	L	Dominant
H or open	X		Z	Z	Recessive
X	H		Z	Z	Recessive

Table 4. RECEIVER (SN65HVD253)

INPUTS			OUTPUT	
AB	BUS STATE	$V_{ID} = V_{CANH} - V_{CANL}$	TXD	RXD
L or open	Dominant	$V_{ID} \geq 0.9 V$	X	L
	?	$0.5 V < V_{ID} < 0.9 V$		?
	Recessive	$V_{ID} \leq 0.5 V$		H
	Open	$V_{ID} \approx 0 V$		H
H	Dominant	$V_{ID} \geq 0.9 V$	X	L
	?	$0.5 V < V_{ID} < 0.9 V$	L	L
	Recessive	$V_{ID} \leq 0.5 V$ or open	H	H
X	X	X	L	L

**ABSOLUTE MAXIMUM RATINGS<sup>(1)</sup>**

	VALUE	UNIT
Supply voltage <sup>(2)</sup> , V <sub>CC</sub>	–0.3 to 6	V
Voltage range at CANH, CANL, V <sub>REF</sub>	–36 to 40	V
Voltage at CANH, CANL, transient pulse per ISO 7637, pulse 1, 2, 3a, 3b, 5, 6, 7	–200 to 200	V
Voltage input range at logic inputs, V <sub>I</sub> (TXD, AB, RXD, S)	–0.5 to 6	V
ESD, human-body model (HBM) per JEDEC Standard 22, test method A114, CANH, CANL vs GND	±12	kV
ESD, human-body model (HBM) per JEDEC Standard 22, test method A114, all pins	±5	kV
ESD, charged-device model (CDM) per JEDEC Standard 22, test method C101, all pins	±2	kV
ESD, machine model (MM) per JEDEC Standard 22, test method A115 CANH, CANL vs GND	±200	V
Receiver output current, I <sub>O</sub>	±20	mA
Junction temperature, T <sub>J</sub>	170	°C

- (1) Stresses beyond those listed under *Absolute Maximum Ratings* may cause permanent damage to the device. These are stress ratings only, and functional operation of the device at these or any other conditions beyond those indicated under *Recommended Operating Conditions* is not implied. Exposure to absolute-maximum-rated conditions for extended periods may affect device reliability.
- (2) All voltage values, except differential I/O bus voltages, are with respect to ground terminal.

**RECOMMENDED OPERATING CONDITIONS**

		MIN	MAX	UNIT	
V <sub>CC</sub>	Supply voltage	4.75	5.25	V	
	Voltage at any bus terminal (separately or common mode)	–5 <sup>(1)</sup>	10	V	
V <sub>IH</sub>	High-level input voltage	2	5.5	V	
V <sub>IL</sub>	Low-level input voltage	0	0.8	V	
V <sub>ID</sub>	Differential input voltage	–7	7	V	
I <sub>OH</sub>	Output current	Driver	–70	70	mA
		Receiver	–2	2	
T <sub>A</sub>	Operating ambient free-air temperature	–40	85	°C	

- (1) The algebraic convention, in which the least positive (most negative) limit is designated as minimum is used in this data sheet.

## THERMAL INFORMATION

THERMAL METRIC		HVD252/53	UNITS	
		8 PINS SOIC		
$\theta_{JA}$	Junction-to-ambient thermal resistance <sup>(1)</sup>	124.5	°C/W	
$\theta_{JC(top)}$	Junction-to-case(top) thermal resistance <sup>(2)</sup>	55.9		
$\theta_{JB}$	Junction-to-board thermal resistance <sup>(3)</sup>	50.2		
$\psi_{JT}$	Junction-to-top characterization parameter <sup>(4)</sup>	4.9		
$\psi_{JB}$	Junction-to-board characterization parameter <sup>(5)</sup>	46		
$\theta_{JC(bottom)}$	Junction-to-case(bottom) thermal resistance <sup>(6)</sup>	n/a		
$P_D$	Device power dissipation	$V_{CC} = 5\text{ V}$ , $T_J = 27^\circ\text{C}$ , $R_L = 60\ \Omega$ , $R_S$ at 0 V, Input to D a 500-kHz 50% duty cycle square wave	189.1	mW
		$V_{CC} = 5.25\text{ V}$ , $T_J = 150^\circ\text{C}$ , $R_L = 50\ \Omega$ , $R_S$ at 0 V, Input to D a 500-kHz 50% duty cycle square wave	274.8	mW

- (1) The junction-to-ambient thermal resistance under natural convection is obtained in a simulation on a JEDEC-standard, high-K board, as specified in JESD51-7, in an environment described in JESD51-2a.
- (2) The junction-to-case (top) thermal resistance is obtained by simulating a cold plate test on the package top. No specific JEDEC-standard test exists, but a close description can be found in the ANSI SEMI standard G30-88.
- (3) The junction-to-board thermal resistance is obtained by simulating in an environment with a ring cold plate fixture to control the PCB temperature, as described in JESD51-8.
- (4) The junction-to-top characterization parameter,  $\psi_{JT}$ , estimates the junction temperature of a device in a real system and is extracted from the simulation data for obtaining  $\theta_{JA}$ , using a procedure described in JESD51-2a (sections 6 and 7).
- (5) The junction-to-board characterization parameter,  $\psi_{JB}$ , estimates the junction temperature of a device in a real system and is extracted from the simulation data for obtaining  $\theta_{JA}$ , using a procedure described in JESD51-2a (sections 6 and 7).
- (6) The junction-to-case (bottom) thermal resistance is obtained by simulating a cold plate test on the exposed (power) pad. No specific JEDEC standard test exists, but a close description can be found in the ANSI SEMI standard G30-88.

## DRIVER ELECTRICAL CHARACTERISTICS

over recommended operating conditions (unless otherwise noted)

PARAMETER		TEST CONDITIONS		MIN	TYP <sup>(1)</sup>	MAX	UNIT
$V_{O(D)}$	Bus output voltage (dominant)	CANH	See Figure 1, TXD = 0 V, S = 0 V, AB = 0 V (HVD253), $R_{CM} = \text{open}$ , $C_L = \text{open}$ , $R_L = 60\ \Omega$	2.75	3.5	4.5	V
		CANL		0.5	1.5	2.25	
$V_{O(R)}$	Bus output voltage (recessive)	TXD = 3 V, S = 0 V	No Load	2	2.5	3	V
$V_{OD(D)}$	Differential output voltage (dominant)	See Figure 1, TXD = 0 V, S = 0 V, $R_{CM} = \text{open}$ , $C_L = \text{open}$ , $45\ \Omega \leq R_L \leq 60\ \Omega$		1.5	2.4	3.4	V
		See Figure 1, TXD = 0 V, S = 0 V, $R_L = 60\ \Omega$ , $R_{CM} = 330\ \Omega$ , $C_L = \text{open}$ , $-5\text{ V} < V_{CM} < 10\text{ V}$		1.2	2.6	3.3	
$V_{OD(R)}$	Differential output voltage (recessive)	See Figure 1, TXD = 3 V, S = 0 V, $R_{CM} = \text{open}$ , $C_L = 100\text{ pF}$	$R_L = 60\ \Omega$	-12		12	mV
			No load	-100		50	
$V_{SYM}$	Output symmetry (dominant or recessive)	See Figure 1, S = 0 V, AB = 0 V (HVD253), $R_{CM} = \text{open}$ , $C_L = \text{open}$ , $R_L = 60\ \Omega$ , $V_{SYM} = V_{CC} - V_{CANH} - V_{CANL}$		-400	0	400	mV
$I_{OS(ss)}$	Short-circuit steady-state output current	$-5\text{ V} < V_{CANH} < 10\text{ V}$ , CANL open		-350		2.5	mA
		$-5\text{ V} < V_{CANL} < 10\text{ V}$ , CANH open		-2.5		350	

- (1) All typical values are at 25°C with  $V_{CC} = 5\text{ V}$ .

## DRIVER SWITCHING CHARACTERISTICS

PARAMETER		TEST CONDITIONS	MIN	TYP	MAX	UNIT
$t_{pHR}$	Propagation delay time, high input to recessive output	See Figure 1, S = 0 V, $R_L = 60\ \Omega$ , $C_L = 100\text{ pF}$ , $R_{CM} = \text{open}$		50	70	ns
$t_{pLD}$	Propagation delay time, low input to dominant output			40	70	
$t_r$	Differential output signal rise time, 10% to 90%			15	30	
$t_f$	Differential output signal fall time, 90% to 10%			17	30	
$t_{en}$	Enable time from silent mode to dominant	$R_L = 60\ \Omega$ , $C_L = 15\text{ pF}$ , $C_{LD} = 100\text{ pF}$			200	ns

## RECEIVER ELECTRICAL CHARACTERISTICS

over recommended operating conditions (unless otherwise noted)

PARAMETER		TEST CONDITIONS	MIN	TYP <sup>(1)</sup>	MAX	UNIT	
V <sub>IT+</sub>	Positive-going input threshold voltage	-5 V < V <sub>CM</sub> < 10 V		800	900	mV	
V <sub>IT-</sub>	Negative-going input threshold voltage		500	650			
V <sub>hys</sub>	Hysteresis voltage (V <sub>IT+</sub> - V <sub>IT-</sub> )		140	160			
V <sub>OH</sub>	High-level output voltage	I <sub>O</sub> = -2 mA	2.4	3.3	3.7	V	
		I <sub>O</sub> = -20 μA	2.7	3.3	3.7		
V <sub>OL</sub>	Low-level output voltage	I <sub>O</sub> = 2 mA		0.1	0.2	V	
I <sub>BL(off)</sub>	Bus leakage current, with power off	CANH or CANL, Other bus pin at 0 V	V <sub>CC</sub> at 0 V		-600	600	μA
I <sub>BL</sub>	Bus leakage current, in silent mode or recessive state		TXD or S pin at V <sub>CC</sub>		-600	600	
C <sub>I</sub>	Input capacitance to ground, (CANH or CANL)	V <sub>I</sub> = 0.4 sin(4E6πt) + 2.5 V		20		pF	
C <sub>ID</sub>	Differential input capacitance	V <sub>I</sub> = 0.4 sin(4E6πt)		7		pF	
R <sub>ID</sub>	Differential input resistance	TXD at 3 V, S at 0 V	30	60	80	kΩ	
R <sub>IN</sub>	Input resistance, (CANH or CANL)		15	30	40	kΩ	
R <sub>I(M)</sub>	Input resistance matching [1 - (R <sub>IN(CANH)</sub> / R <sub>IN(CANL)</sub> )] × 100%	V <sub>CANH</sub> = V <sub>CANL</sub>	-3%	0%	3%		

 (1) All typical values are at 25°C with V<sub>CC</sub> = 5 V.

## RECEIVER SWITCHING CHARACTERISTICS

over recommended operating conditions (unless otherwise noted)

PARAMETER		TEST CONDITIONS	MIN	TYP	MAX	UNIT
t <sub>pRH</sub>	Propagation delay time, recessive input to high output	See <a href="#">Figure 2</a> , C <sub>L</sub> = 15 pF, AB = 0 V or V <sub>CC</sub> (HVD253)		55	80	ns
t <sub>pDL</sub>	Propagation delay time, dominant input to low output		50	80		
t <sub>r</sub>	Output signal rise time, 10% to 90%		20			
t <sub>f</sub>	Output signal fall time, 90% to 10%		20			

## DRIVER-TO-RECEIVER LOOP-SWITCHING CHARACTERISTICS

over recommended operating conditions (unless otherwise noted)

PARAMETER		TEST CONDITIONS	MIN	TYP	MAX	UNIT	
t <sub>loop1</sub>	Total loop delay, driver input to receiver output	Recessive to dominant	See <a href="#">Figure 4</a> , S at 0 V, AB at 0 V, R <sub>L</sub> = 60 Ω, C <sub>LD</sub> = 100 pF, C <sub>L</sub> = 15 pF	40	90	140	ns
t <sub>loop2</sub>		Dominant to recessive		40	105	140	
t <sub>AB1</sub>	Loopback delay, driver input to receiver output (HVD253 only)	See <a href="#">Figure 5</a> , S at 0 V, AB = V <sub>CC</sub> , R <sub>L</sub> = 60 Ω, C <sub>LD</sub> = 100 pF, C <sub>L</sub> = 15 pF		20	40	ns	

### LOGIC INPUT PIN CHARACTERISTICS (D, S, AND AB INPUTS)

over recommended operating conditions (unless otherwise noted)

PARAMETER		TEST CONDITIONS	MIN	TYP	MAX	UNIT
$I_I$	Input current	$0\text{ V} < V_{IN} < V_{CC}$	-100		100	$\mu\text{A}$
$I_{OP(off)}$	Power-off leakage current	$V_{CC}$ at 0 V, $0 < V_{IN} < V_{CC(MAX)}$	-100		100	$\mu\text{A}$

### $V_{REF}$ PIN CHARACTERISTICS

over recommended operating conditions (unless otherwise noted)

PARAMETER		TEST CONDITIONS	MIN	TYP	MAX	UNIT
$V_O$	Output voltage	$-100\ \mu\text{A} < I_O < 100\ \mu\text{A}$	$0.4\ V_{CC}$	$0.5V_{CC}$	$0.6V_{CC}$	V
		$-50\ \mu\text{A} < I_O < 50\ \mu\text{A}$	$0.43\ V_{CC}$	$0.5V_{CC}$	$0.57\ V_{CC}$	
		$-5\ \mu\text{A} < I_O < 5\ \mu\text{A}$	$0.45\ V_{CC}$	$0.5V_{CC}$	$0.55\ V_{CC}$	

### SUPPLY CURRENT

over recommended operating conditions (unless otherwise noted)

PARAMETER			TEST CONDITIONS	MIN	TYP	MAX	UNIT	
$I_{CC}$	Supply current	HVD252	S at $V_{CC}$ , TXD at $V_{CC}$		13	17	mA	
		HVD253						S at $V_{CC}$ , AB at 0 V or $V_{CC}$
		All	Dominant					TXD at 0 V, 50- $\Omega$ load, S at 0 V
			Recessive					TXD at $V_{CC}$ , no load, S at 0 V

PARAMETER MEASUREMENT INFORMATION

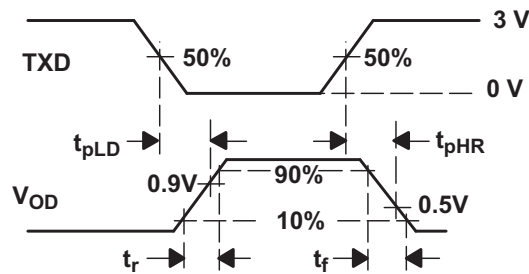
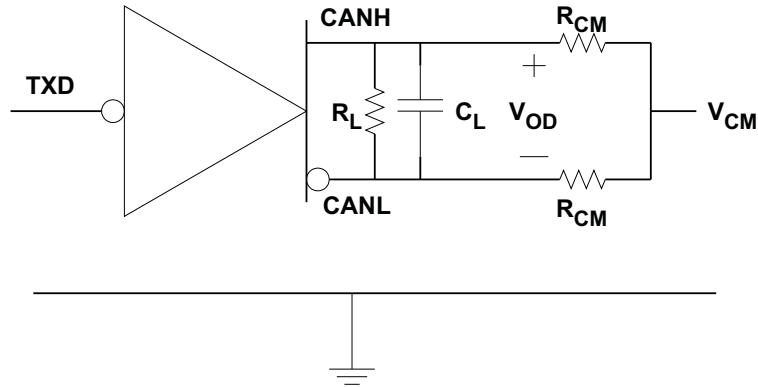

Figure 1. Driver Test Circuit

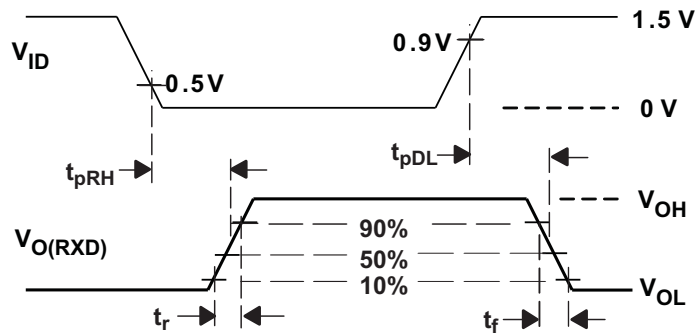
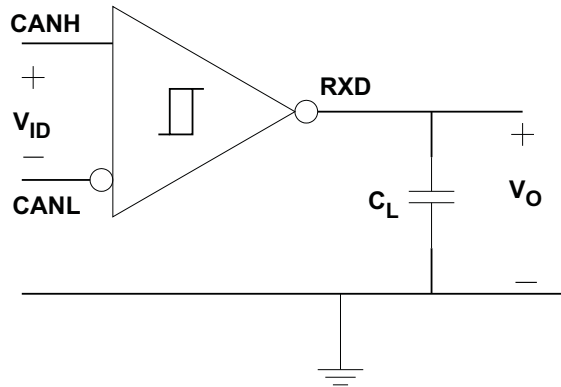

Figure 2. Receiver Test Circuit

PARAMETER MEASUREMENT INFORMATION (continued)

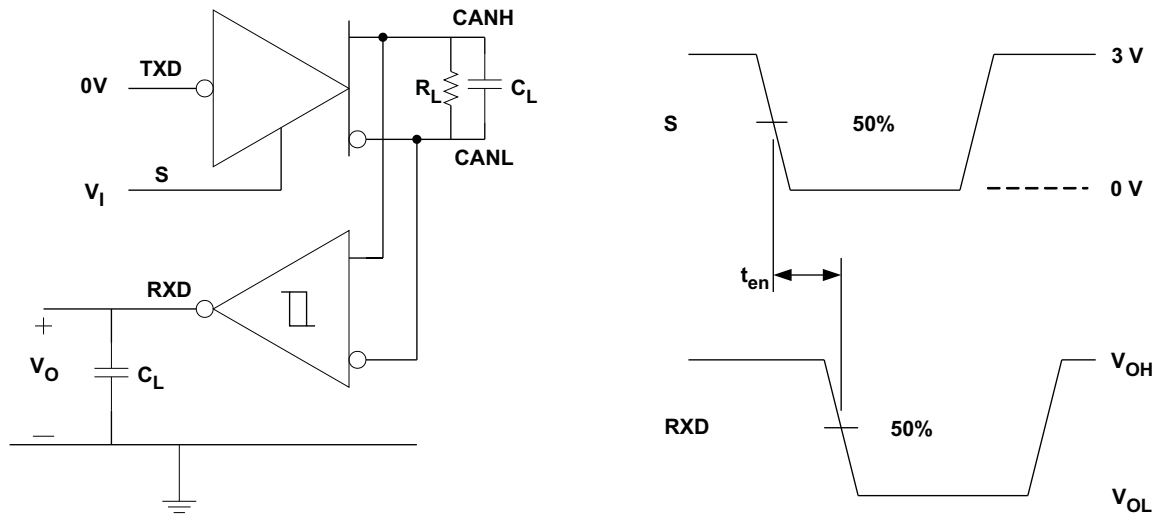

Figure 3. Enable Test Circuit

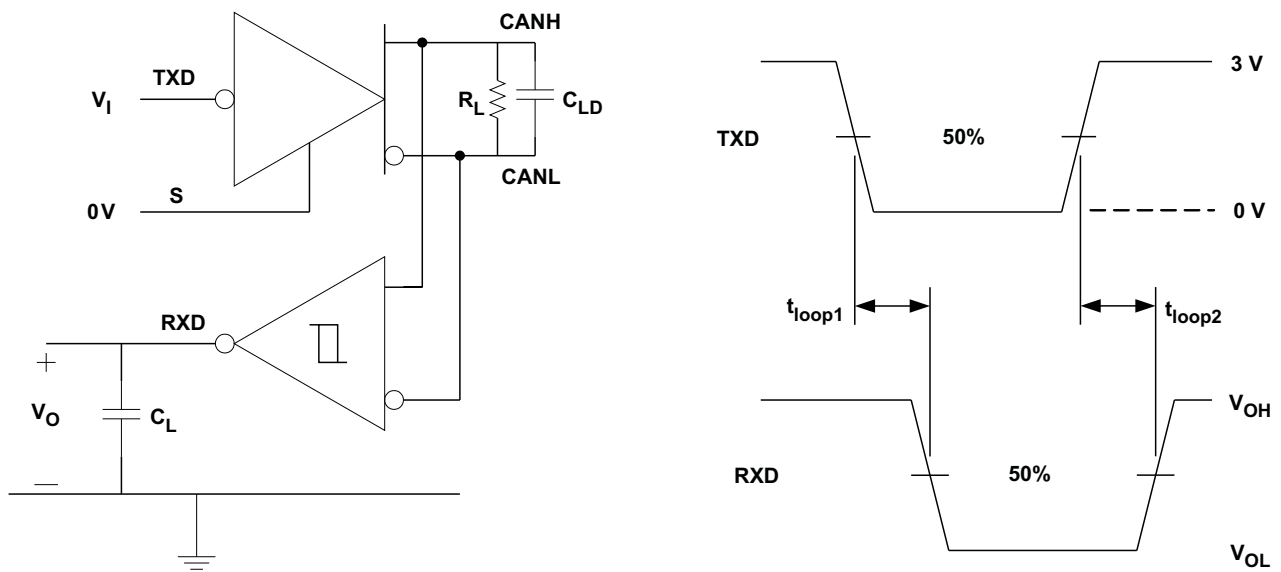

Figure 4. Loop Time Measurements



PARAMETER MEASUREMENT INFORMATION (continued)

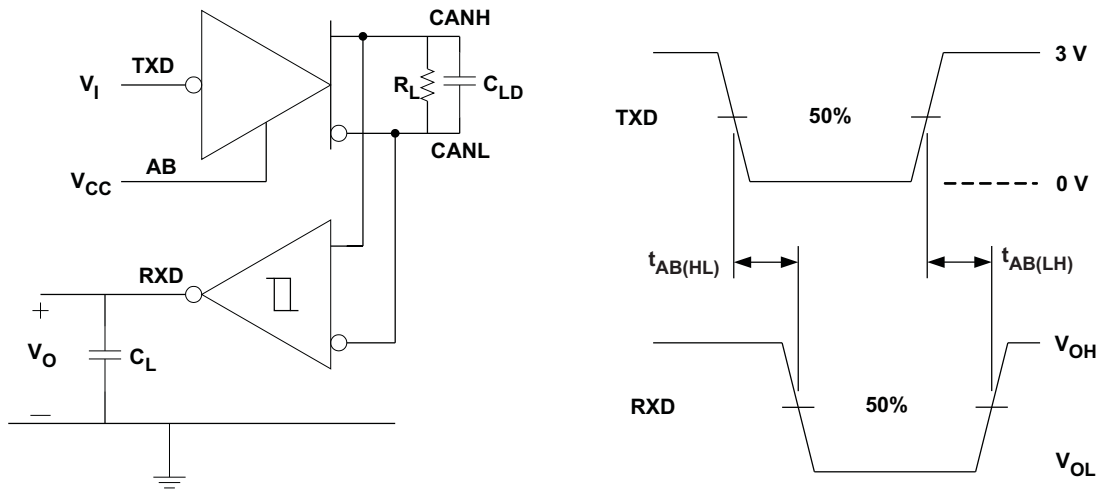
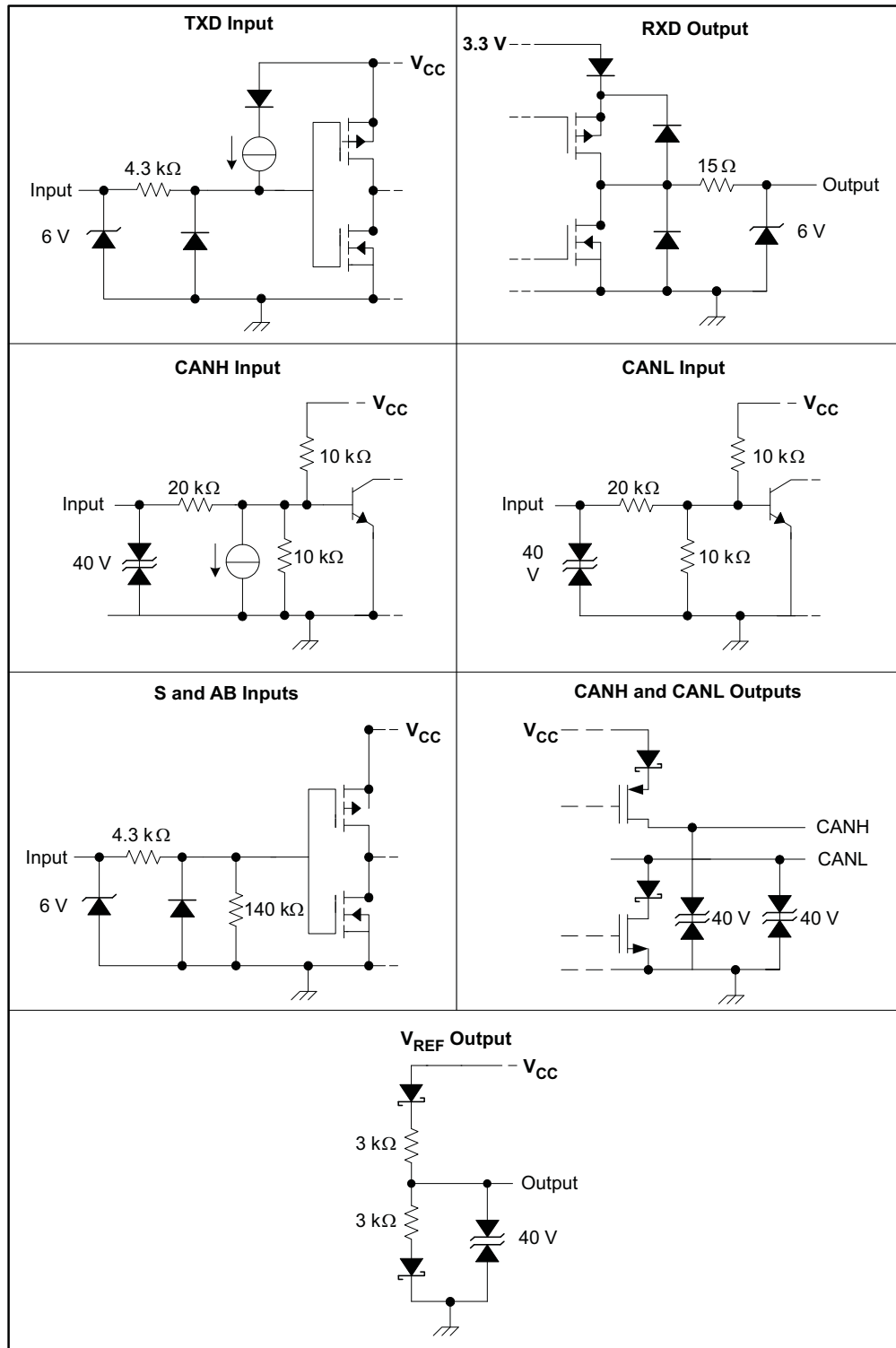

Figure 5. Loopback Timing Measurement

**PARAMETER MEASUREMENT INFORMATION (continued)**  
**EQUIVALENT INPUT AND OUTPUT SCHEMATIC DIAGRAMS**



## APPLICATION INFORMATION

### USING THE SILENT MODE

The silent mode is selected by setting a logic high on pin 8 (S). In silent mode, the driver function of the transceiver is disabled, whereas the receiver function remains active. This silent mode may be used to implement *babbling idiot* protection, to ensure that the driver does not disrupt the entire network in case of a local fault. The silent mode may also be used in redundant systems to select or de-select the redundant transceiver until needed.

### USING THE AUTOBAUD FEATURE OF THE SN65HVD253

The autobaud feature of the HVD253 is selected by placing a logic high on pin 5 (AB). In autobaud mode, the normal *bus-transmit* function of the transceiver is disabled, whereas the *bus-receive* function and all of the other normal operating functions of the device remain active. An internal loopback emulates the connection between the driver outputs and the receiver inputs, allowing the receiver to respond to locally-generated dominant bits as well as dominant bits from other nodes.

With the autobaud function engaged, normal bus activity, including activity from the local controller, can be monitored by the local node as received data. However, if an error frame is generated by the local CAN controller, it is not transmitted to the bus. Only the local microprocessor can detect the error frame.

Autobaud detection is well suited to applications that have a known selection of baud rates. For example, DeviceNet (a common industrial protocol) has optional signaling rates of 125 kbps, 250 kbps, or 500 kbps. Once a logic high has been applied to pin 5 (AB) of the HVD253, the local controller may assume a baud rate such as 125 kbps and then wait for a message to be transmitted by another node on the bus. If the wrong local signaling rate has been selected, an error message is generated by the local CAN controller. However, because the *bus-transmit* function of the transceiver has been disabled, no other nodes receive the error message from the local controller.

This procedure makes use of the CAN controller status-register indications of message received and error warning status to signal if the current signaling rate is correct or not. The warning status indicates that the CAN controller error counters have been incremented. A message-received status indicates that a good message has been received.

If an error is generated, the local CAN controller may assume another signaling rate and wait to receive another message. When an error-free message has been received, the correct baud rate has been selected. A logic low may now be applied to pin 5 (AB) of the HVD253, returning the *bus-transmit* normal operating function to the transceiver.

### USING THE $V_{REF}$ OUTPUT

The  $V_{REF}$  output provides a stable voltage of half the power supply voltage. This can be used in split-termination schemes to improve electromagnetic compatibility (EMC) of the system. It can also be used as a reference with which to compare the single-ended inputs for degraded operation in the event of a wire-break fault on either the CANH or CANL bus lines.

### DeviceNet REQUIREMENTS

DeviceNet requires additional performance beyond the requirements of the ISO 11898-2 CAN standard. These additional specifications address the conditions found in rugged industrial applications. The DeviceNet specifications are maintained by ODVA. ([www.odva.org](http://www.odva.org)) The HVD252 and HVD253 fully meet these requirements under all recommended operating conditions.

PARAMETER	DeviceNet SPECIFICATION	HVD252, HVD253
Number of nodes	64	Yes
Minimum differential input resistance	20 k $\Omega$	Yes
Minimum differential input capacitance	24 pF	Yes
Bus pin voltage range (survivable)	-25 V to 18 V	Yes
Bus pin voltage range (operation)	-5 V to 10 V	Yes
Differential output voltage	1.5 V with 50- $\Omega$ load	Yes

## PACKAGING INFORMATION

Orderable Device	Status (1)	Package Type	Package Drawing	Pins	Package Qty	Eco Plan (2)	Lead/Ball Finish	MSL Peak Temp (3)	Op Temp (°C)	Top-Side Markings (4)	Samples
SN65HVD252D	ACTIVE	SOIC	D	8	75	Green (RoHS & no Sb/Br)	CU NIPDAU	Level-1-260C-UNLIM	-40 to 85	HVD252	<a href="#">Samples</a>
SN65HVD252DR	ACTIVE	SOIC	D	8	2500	Green (RoHS & no Sb/Br)	CU NIPDAU	Level-1-260C-UNLIM	-40 to 85	HVD252	<a href="#">Samples</a>
SN65HVD253D	ACTIVE	SOIC	D	8	75	Green (RoHS & no Sb/Br)	CU NIPDAU	Level-1-260C-UNLIM	-40 to 85	HVD253	<a href="#">Samples</a>
SN65HVD253DR	ACTIVE	SOIC	D	8	2500	Green (RoHS & no Sb/Br)	CU NIPDAU	Level-1-260C-UNLIM	-40 to 85	HVD253	<a href="#">Samples</a>

(1) The marketing status values are defined as follows:

**ACTIVE:** Product device recommended for new designs.

**LIFEBUY:** TI has announced that the device will be discontinued, and a lifetime-buy period is in effect.

**NRND:** Not recommended for new designs. Device is in production to support existing customers, but TI does not recommend using this part in a new design.

**PREVIEW:** Device has been announced but is not in production. Samples may or may not be available.

**OBSOLETE:** TI has discontinued the production of the device.

(2) Eco Plan - The planned eco-friendly classification: Pb-Free (RoHS), Pb-Free (RoHS Exempt), or Green (RoHS & no Sb/Br) - please check <http://www.ti.com/productcontent> for the latest availability information and additional product content details.

**TBD:** The Pb-Free/Green conversion plan has not been defined.

**Pb-Free (RoHS):** TI's terms "Lead-Free" or "Pb-Free" mean semiconductor products that are compatible with the current RoHS requirements for all 6 substances, including the requirement that lead not exceed 0.1% by weight in homogeneous materials. Where designed to be soldered at high temperatures, TI Pb-Free products are suitable for use in specified lead-free processes.

**Pb-Free (RoHS Exempt):** This component has a RoHS exemption for either 1) lead-based flip-chip solder bumps used between the die and package, or 2) lead-based die adhesive used between the die and leadframe. The component is otherwise considered Pb-Free (RoHS compatible) as defined above.

**Green (RoHS & no Sb/Br):** TI defines "Green" to mean Pb-Free (RoHS compatible), and free of Bromine (Br) and Antimony (Sb) based flame retardants (Br or Sb do not exceed 0.1% by weight in homogeneous material)

(3) MSL, Peak Temp. -- The Moisture Sensitivity Level rating according to the JEDEC industry standard classifications, and peak solder temperature.

(4) Only one of markings shown within the brackets will appear on the physical device.

**Important Information and Disclaimer:** The information provided on this page represents TI's knowledge and belief as of the date that it is provided. TI bases its knowledge and belief on information provided by third parties, and makes no representation or warranty as to the accuracy of such information. Efforts are underway to better integrate information from third parties. TI has taken and continues to take reasonable steps to provide representative and accurate information but may not have conducted destructive testing or chemical analysis on incoming materials and chemicals. TI and TI suppliers consider certain information to be proprietary, and thus CAS numbers and other limited information may not be available for release.

In no event shall TI's liability arising out of such information exceed the total purchase price of the TI part(s) at issue in this document sold by TI to Customer on an annual basis.

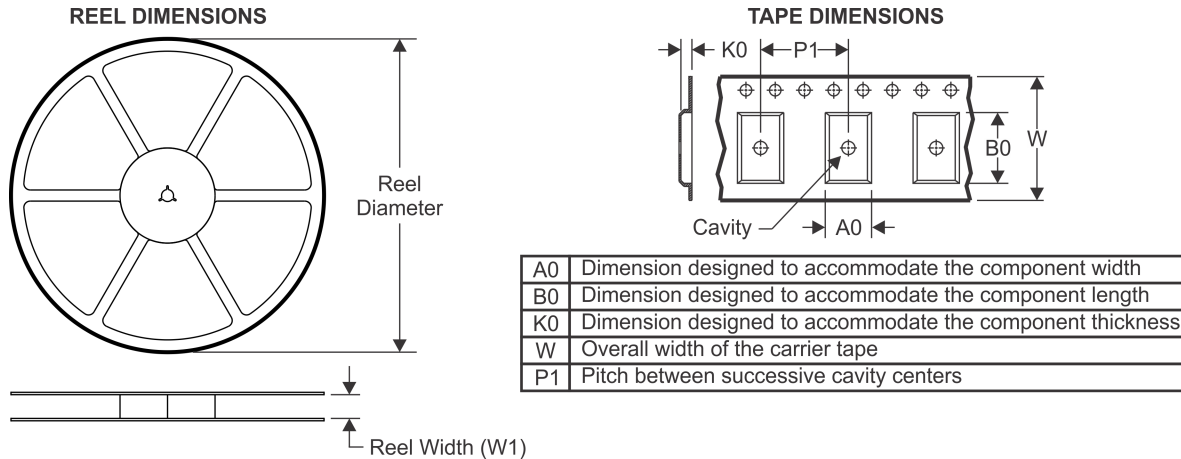

**TAPE AND REEL INFORMATION**

**QUADRANT ASSIGNMENTS FOR PIN 1 ORIENTATION IN TAPE**

\*All dimensions are nominal

Device	Package Type	Package Drawing	Pins	SPQ	Reel Diameter (mm)	Reel Width W1 (mm)	A0 (mm)	B0 (mm)	K0 (mm)	P1 (mm)	W (mm)	Pin1 Quadrant
SN65HVD252DR	SOIC	D	8	2500	330.0	12.4	6.4	5.2	2.1	8.0	12.0	Q1
SN65HVD253DR	SOIC	D	8	2500	330.0	12.4	6.4	5.2	2.1	8.0	12.0	Q1

**TAPE AND REEL BOX DIMENSIONS**



\*All dimensions are nominal

Device	Package Type	Package Drawing	Pins	SPQ	Length (mm)	Width (mm)	Height (mm)
SN65HVD252DR	SOIC	D	8	2500	367.0	367.0	35.0
SN65HVD253DR	SOIC	D	8	2500	367.0	367.0	35.0

D (R-PDSO-G8)

PLASTIC SMALL OUTLINE



- NOTES:
- A. All linear dimensions are in inches (millimeters).
  - B. This drawing is subject to change without notice.
  -  Body length does not include mold flash, protrusions, or gate burrs. Mold flash, protrusions, or gate burrs shall not exceed 0.006 (0,15) each side.
  -  Body width does not include interlead flash. Interlead flash shall not exceed 0.017 (0,43) each side.
  - E. Reference JEDEC MS-012 variation AA.



D (R-PDSO-G8)

PLASTIC SMALL OUTLINE



- NOTES:
- A. All linear dimensions are in millimeters.
  - B. This drawing is subject to change without notice.
  - C. Publication IPC-7351 is recommended for alternate designs.
  - D. Laser cutting apertures with trapezoidal walls and also rounding corners will offer better paste release. Customers should contact their board assembly site for stencil design recommendations. Refer to IPC-7525 for other stencil recommendations.
  - E. Customers should contact their board fabrication site for solder mask tolerances between and around signal pads.

## IMPORTANT NOTICE

Texas Instruments Incorporated and its subsidiaries (TI) reserve the right to make corrections, enhancements, improvements and other changes to its semiconductor products and services per JESD46, latest issue, and to discontinue any product or service per JESD48, latest issue. Buyers should obtain the latest relevant information before placing orders and should verify that such information is current and complete. All semiconductor products (also referred to herein as "components") are sold subject to TI's terms and conditions of sale supplied at the time of order acknowledgment.

TI warrants performance of its components to the specifications applicable at the time of sale, in accordance with the warranty in TI's terms and conditions of sale of semiconductor products. Testing and other quality control techniques are used to the extent TI deems necessary to support this warranty. Except where mandated by applicable law, testing of all parameters of each component is not necessarily performed.

TI assumes no liability for applications assistance or the design of Buyers' products. Buyers are responsible for their products and applications using TI components. To minimize the risks associated with Buyers' products and applications, Buyers should provide adequate design and operating safeguards.

TI does not warrant or represent that any license, either express or implied, is granted under any patent right, copyright, mask work right, or other intellectual property right relating to any combination, machine, or process in which TI components or services are used. Information published by TI regarding third-party products or services does not constitute a license to use such products or services or a warranty or endorsement thereof. Use of such information may require a license from a third party under the patents or other intellectual property of the third party, or a license from TI under the patents or other intellectual property of TI.

Reproduction of significant portions of TI information in TI data books or data sheets is permissible only if reproduction is without alteration and is accompanied by all associated warranties, conditions, limitations, and notices. TI is not responsible or liable for such altered documentation. Information of third parties may be subject to additional restrictions.

Resale of TI components or services with statements different from or beyond the parameters stated by TI for that component or service voids all express and any implied warranties for the associated TI component or service and is an unfair and deceptive business practice. TI is not responsible or liable for any such statements.

Buyer acknowledges and agrees that it is solely responsible for compliance with all legal, regulatory and safety-related requirements concerning its products, and any use of TI components in its applications, notwithstanding any applications-related information or support that may be provided by TI. Buyer represents and agrees that it has all the necessary expertise to create and implement safeguards which anticipate dangerous consequences of failures, monitor failures and their consequences, lessen the likelihood of failures that might cause harm and take appropriate remedial actions. Buyer will fully indemnify TI and its representatives against any damages arising out of the use of any TI components in safety-critical applications.

In some cases, TI components may be promoted specifically to facilitate safety-related applications. With such components, TI's goal is to help enable customers to design and create their own end-product solutions that meet applicable functional safety standards and requirements. Nonetheless, such components are subject to these terms.

No TI components are authorized for use in FDA Class III (or similar life-critical medical equipment) unless authorized officers of the parties have executed a special agreement specifically governing such use.

Only those TI components which TI has specifically designated as military grade or "enhanced plastic" are designed and intended for use in military/aerospace applications or environments. Buyer acknowledges and agrees that any military or aerospace use of TI components which have **not** been so designated is solely at the Buyer's risk, and that Buyer is solely responsible for compliance with all legal and regulatory requirements in connection with such use.

TI has specifically designated certain components as meeting ISO/TS16949 requirements, mainly for automotive use. In any case of use of non-designated products, TI will not be responsible for any failure to meet ISO/TS16949.

### Products

Audio	<a href="http://www.ti.com/audio">www.ti.com/audio</a>
Amplifiers	<a href="http://amplifier.ti.com">amplifier.ti.com</a>
Data Converters	<a href="http://dataconverter.ti.com">dataconverter.ti.com</a>
DLP® Products	<a href="http://www.dlp.com">www.dlp.com</a>
DSP	<a href="http://dsp.ti.com">dsp.ti.com</a>
Clocks and Timers	<a href="http://www.ti.com/clocks">www.ti.com/clocks</a>
Interface	<a href="http://interface.ti.com">interface.ti.com</a>
Logic	<a href="http://logic.ti.com">logic.ti.com</a>
Power Mgmt	<a href="http://power.ti.com">power.ti.com</a>
Microcontrollers	<a href="http://microcontroller.ti.com">microcontroller.ti.com</a>
RFID	<a href="http://www.ti-rfid.com">www.ti-rfid.com</a>
OMAP Applications Processors	<a href="http://www.ti.com/omap">www.ti.com/omap</a>
Wireless Connectivity	<a href="http://www.ti.com/wirelessconnectivity">www.ti.com/wirelessconnectivity</a>

### Applications

Automotive and Transportation	<a href="http://www.ti.com/automotive">www.ti.com/automotive</a>
Communications and Telecom	<a href="http://www.ti.com/communications">www.ti.com/communications</a>
Computers and Peripherals	<a href="http://www.ti.com/computers">www.ti.com/computers</a>
Consumer Electronics	<a href="http://www.ti.com/consumer-apps">www.ti.com/consumer-apps</a>
Energy and Lighting	<a href="http://www.ti.com/energy">www.ti.com/energy</a>
Industrial	<a href="http://www.ti.com/industrial">www.ti.com/industrial</a>
Medical	<a href="http://www.ti.com/medical">www.ti.com/medical</a>
Security	<a href="http://www.ti.com/security">www.ti.com/security</a>
Space, Avionics and Defense	<a href="http://www.ti.com/space-avionics-defense">www.ti.com/space-avionics-defense</a>
Video and Imaging	<a href="http://www.ti.com/video">www.ti.com/video</a>

### TI E2E Community

[e2e.ti.com](http://e2e.ti.com)