

PHILIPS SAA9730

INTEGRATED MULTIMEDIA & PERIPHERAL CONTROLLER

SAA9730 from Philips Semiconductors is a highly integrated ASIC targeted for Windows-Based Terminals (Thin client) and Internet Access Terminal markets. In a SAA9730 Windows Based Terminal system, the applications run on a host server. There is no hard disk associated with each of these client systems, and all the clients use the server hard disk. The windows based terminal connects to the server through a 10/100 Ethernet LAN, integrated into SAA9730. The three-IC solution for a WBT (Windows Based Terminal) includes a CPU, a CPU interface and SAA9730. The CPU processes the network commands and instructs the SAA9730 to do the processing. It can drive either a CRT display or the television monitor. As an Internet Access Terminal, the SAA9730 receives analog or digital video data from the video port, processes it and displays the output on CRT and/or television monitor. SAA9730 based Internet Access Terminal will also allow the user to access the World Wide Web, thus enabling them to access huge data bases, email, games, etc. The SAA9730 based high-level system block diagram is shown below:

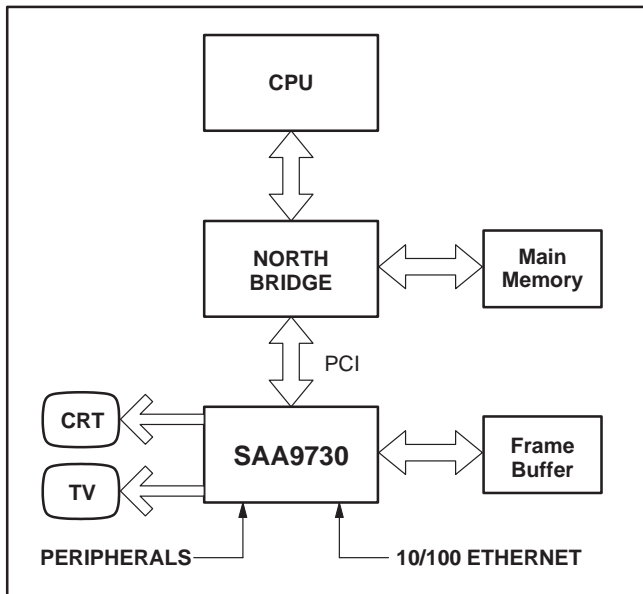

SAA9730 software support

- WinCE 2.1 (Birch EP)
- Full Device Driver Suite
- Adaption kit for MS Windows based terminals (WBT)
- Adaption kit for Internet Terminal
- Sample Diagnostic modules
- Platform Builder SDK
- ActiveX control for video controls
- OAL (OEM Adaption Layer)

SAA9730 supported reference design

- Includes a SAA9730 motherboard and a Video source personality card
- SAA9730 motherboard includes:
 - MIPS processor
 - SAA9730 Video and I/O
 - North Bridge interface between PCI, memory and CPU
 - Single Digital Receiver interface

SAA9730 availability

- | | |
|------------------------------|--------|
| ■ Silicon samples | Now |
| ■ Limited volume | Q1 '99 |
| ■ High volume | Q2 '99 |
| ■ Reference Board & Software | Now |

Let's make things better.

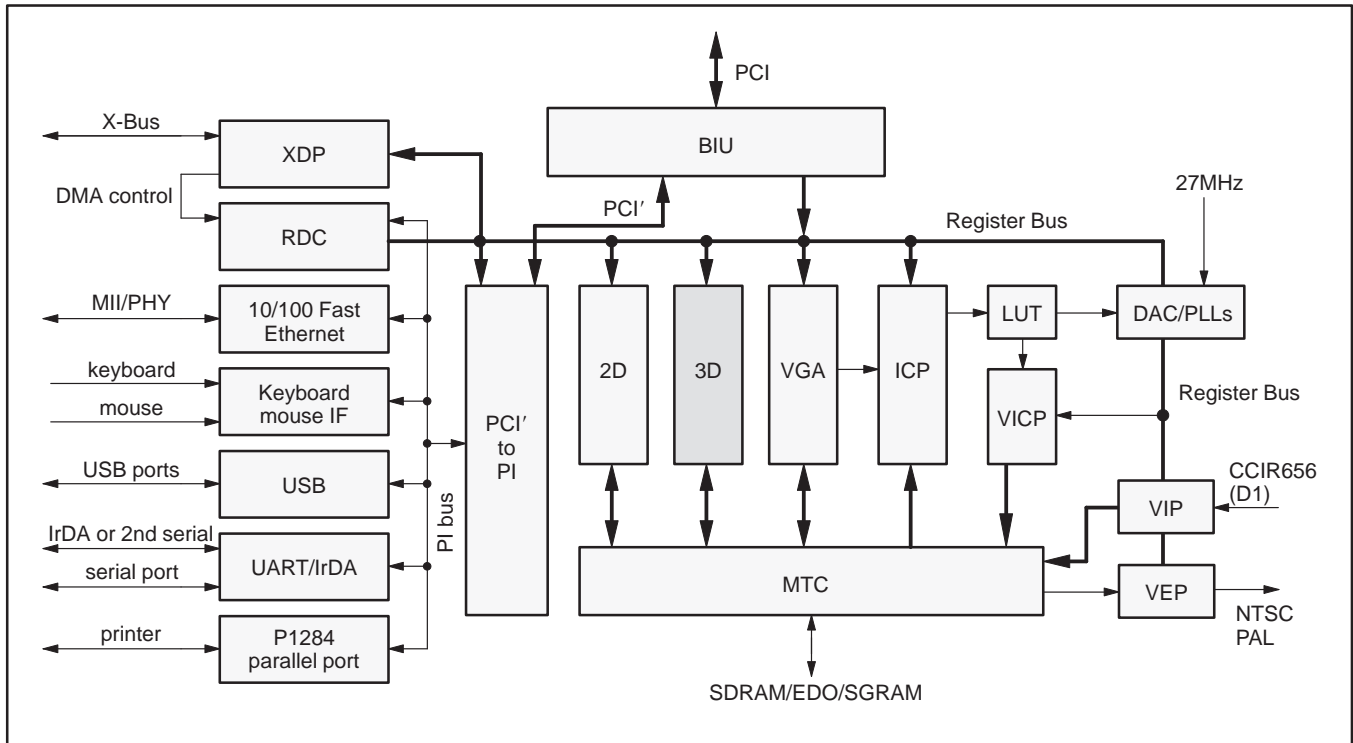

SAA9730 features

- 32-bit, 33 MHz PCI 2.1 interface
- 64-bit, 100 MHz SGRAM
- 64-bit, 66 MHz EDO memory interface
- Accelerated 2D graphics
- 3D rendering engine (setup on CPU)
- Digital Video input
- High resolution: up to 1600 × 1200
- Display resolution: 8, 16, 24, 32 bits/pixel
- Simultaneous CRT & TV (NTSC/PAL) displays
- Integrated 220 MHz RAM DAC and Digital Encoder
- 10/100 Ethernet MAC
- P1284 parallel port
- 2 USB host ports
- 16550-compatible UART
- PS2 style keyboard and mouse interface
- IR interface (115Kbs)
- I²C interface
- DDC interface
- Xbus (expansion bus) supports:
 - BIOS ROM
 - Audio and/or Modem Codec
 - 24-bit RGB capable of driving an external flat panel transmitter
 - MPEG/AC-3 decoder

Let's make things better.