

PRELIMINARY

FEATURES

- DELIVERS UP TO 5A CONTINUOUS OUTPUT
- OPERATES AT SUPPLY VOLTAGES TO 55V
- TTL AND CMOS COMPATIBLE INPUTS
- NO "SHOOT-THROUGH" CURRENT
- THERMAL WARNING FLAG OUTPUT AT 145°C
- THERMAL SHUTDOWN (OUTPUTS OFF) AT 160°C
- INTERNAL CLAMP DIODES
- SHORTED LOAD PROTECTION
- INTERNAL CHARGE PUMP WITH EXTERNAL BOOTSTRAP CAPABILITY

APPLICATIONS

- DC AND STEPPER MOTOR DRIVES
- POSITION AND VELOCITY SERVOMECHANISMS
- FACTORY AUTOMATION ROBOTS
- NUMERICALLY CONTROLLED MACHINERY
- COMPUTER PRINTERS AND PLOTTERS



DESCRIPTION

The SA55 is a 5A H-Bridge designed for motion control applications. The device is built using a multi-technology process which combines bipolar and CMOS control circuitry with DMOS power devices on the same monolithic structure. Ideal for driving DC and stepper motors; the SA55 accommodates peak output currents up to 10A. An innovative circuit which facilitates low-loss sensing of the output current has been implemented.

BLOCK DIAGRAM

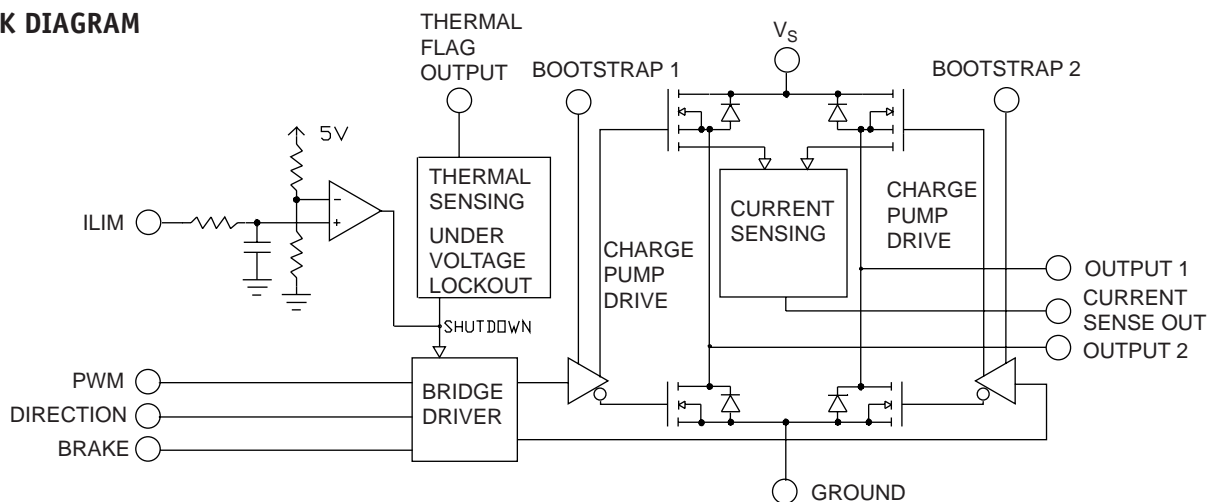

ABSOLUTE MAXIMUM RATINGS

SUPPLY VOLTAGE, V_S , Pin 6	60V
VOLTAGE at Pins 3, 4, 5, 8 and 9	12V
VOLTAGE at Bootstrap Pins (Pins 1 and 11)	$V_{OUT} \pm 16V$
PEAK OUTPUT CURRENT (200mS)	10A
CONTINUOUS OUTPUT CURRENT (Note 2)	5A
POWER DISSIPATION (Note 3)	25W
POWER DISSIPATION ($T_A = 25^\circ C$, Free Air)	3W
JUNCTION TEMPERATURE, $T_{J(MAX)}$	150°C
ESD SUSCEPTIBILITY (Note 4)	1500V
STORAGE TEMPERATURE, T_{STG}	-40°C to +150°C
LEAD TEMPERATURE (Soldering, 10 sec.)	300°C
JUNCTION TEMPERATURE, T_J	-40°C to +125°C
V_S SUPPLY VOLTAGE	+12V to +55V

SPECIFICATIONS

PARAMETER	TEST CONDITIONS	MIN	TYP	MAX	UNITS
SWITCH ON RESISTANCE, $R_{DS(ON)}$	Output Current = 5A		0.33	0.6	Ω
CLAMP DIODE FORWARD DROP, V_{CLAMP}	Clamp Current = 5A		1.2	1.5	V
LOGIC LOW INPUT VOLTAGE, V_{IL}	Pins 3, 4, 5			-0.1	V
				0.8	V
LOGIC LOW INPUT CURRENT, I_{IL}	$V_{IN} = -0.1V$, Pins = 3, 4, 5			-10	μA
LOGIC HIGH INPUT VOLTAGE, V_{IH}	Pins 3, 4, 5			2	V
				12	V
LOGIC HIGH INPUT CURRENT, I_{IH}	$V_{IN} = 12V$, Pins = 3, 4, 5			10	μA
CURRENT SENSE OUTPUT	$I_{OUT} = 1A$		485	560	μA
CURRENT SENSE LINEARITY	$1A \leq I_{OUT} \leq 5A$		± 6	± 9	%
UNDERVOLTAGE LOCKOUT	Outputs Turn OFF			9	V
UNDERVOLTAGE LOCKOUT	Outputs Turn OFF				11 V
WARNING FLAG TEMPERATURE, T_{JW}	Pin 9 $\leq 0.8V$, $I_L = 2 mA$		145		°C
FLAG OUTPUT SATURATION VOLTAGE, $V_F(ON)$	$T_J = T_{JW}$, $I_L = 2 mA$		0.15		V
FLAG OUTPUT LEAKAGE, $I_F(OFF)$	$V_F = 12V$		0.2		μA
SHUTDOWN TEMPERATURE, T_{JSD}	Outputs Turn OFF		160	175	°C
QUIESCENT SUPPLY CURRENT, I_S	All Logic Inputs Low		13	25	mA
OUTPUT TURN-ON DELAY TIME, t_{Don}	Sourcing Outputs, $I_{OUT} = 5A$		300		ns
	Sinking Outputs, $I_{OUT} = 5A$		300		ns
OUTPUT TURN-ON SWITCHING TIME, t_{on}	Bootstrap Capacitor = 10 nF				
	Sourcing Outputs, $I_{OUT} = 5A$		100		ns
	Sinking Outputs, $I_{OUT} = 5A$		80		ns
OUTPUT TURN-OFF DELAY TIMES, t_{Doff}	Sourcing Outputs, $I_{OUT} = 5A$		200		ns
	Sinking Outputs, $I_{OUT} = 5A$		200		ns
OUTPUT TURN-OFF SWITCHING TIME, t_{off}	Bootstrap Capacitor = 10 nF				
	Sourcing Outputs, $I_{OUT} = 5A$		75		ns
	Sinking Outputs, $I_{OUT} = 5A$		70		ns
MINIMUM INPUT PULSE WIDTH, t_{pw}	Pins 3, 4, 5		1		μs
CHARGE PUMP RISE TIME, t_{cpr}	No Bootstrap Capacitor		20		μs

NOTE: These specifications apply for $V_S = 42V$, unless otherwise specified.