

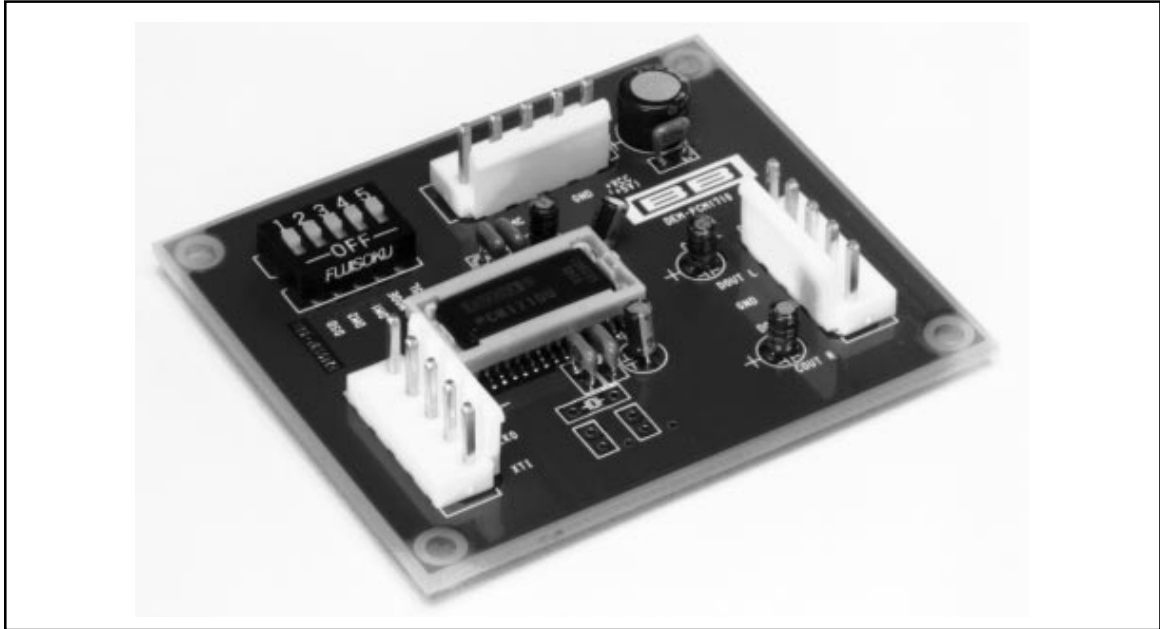

DEM-PCM1710 EVALUATION FIXTURE



FEATURES

- **DUAL MULTI-LEVEL NOISE SHAPING DAC WITH ON-CHIP DIGITAL FILTER**
- **HIGH PERFORMANCE: THD+N: 0.0025%**
Dynamic Range: 98dB typ
S/N Ratio: 110dB typ
- **ANALOG VOLTAGE OUTPUT: $V_o = 3.2V_{p-p}$**
- **ON-CHIP POST ANALOG LOW PASS FILTER**
- **SYSTEM CLOCK 256fs or 384fs**
- **ON-CHIP 8X OVERSAMPLING DIGITAL FILTER WITH:**
Soft Mute and Attenuator
Digital De-Emphasis
Double Speed Dubbing Mode
- **SINGLE +5V POWER SUPPLY**

DESCRIPTION

The DEM-PCM1710 is an evaluation fixture for the PCM1710 (16/20-bit stereo digital-to-analog converter with on-chip digital filter) primarily intended for quick evaluation of the PCM1710's performance.

The DEM-PCM1710 is capable of either serial or parallel output, can accept either an external system clock (256fs or 384fs) or a user-installed crystal oscillator. Other digital input signals are: LRCK, BCK, and DATA.

All of the functions of the PCM1710 (De-Emphasis, Mute, Double Speed) can be easily controlled by on-board switches.

Power supply requirement is +5V only.

International Airport Industrial Park • Mailing Address: PO Box 11400 • Tucson, AZ 85734 • Street Address: 6730 S. Tucson Blvd. • Tucson, AZ 85706
Tel: (602) 746-1111 • Twx: 910-952-1111 • Cable: BBRCORP • Telex: 066-6491 • FAX: (602) 889-1510 • Immediate Product Info: (800) 548-6132

BLOCK DIAGRAM

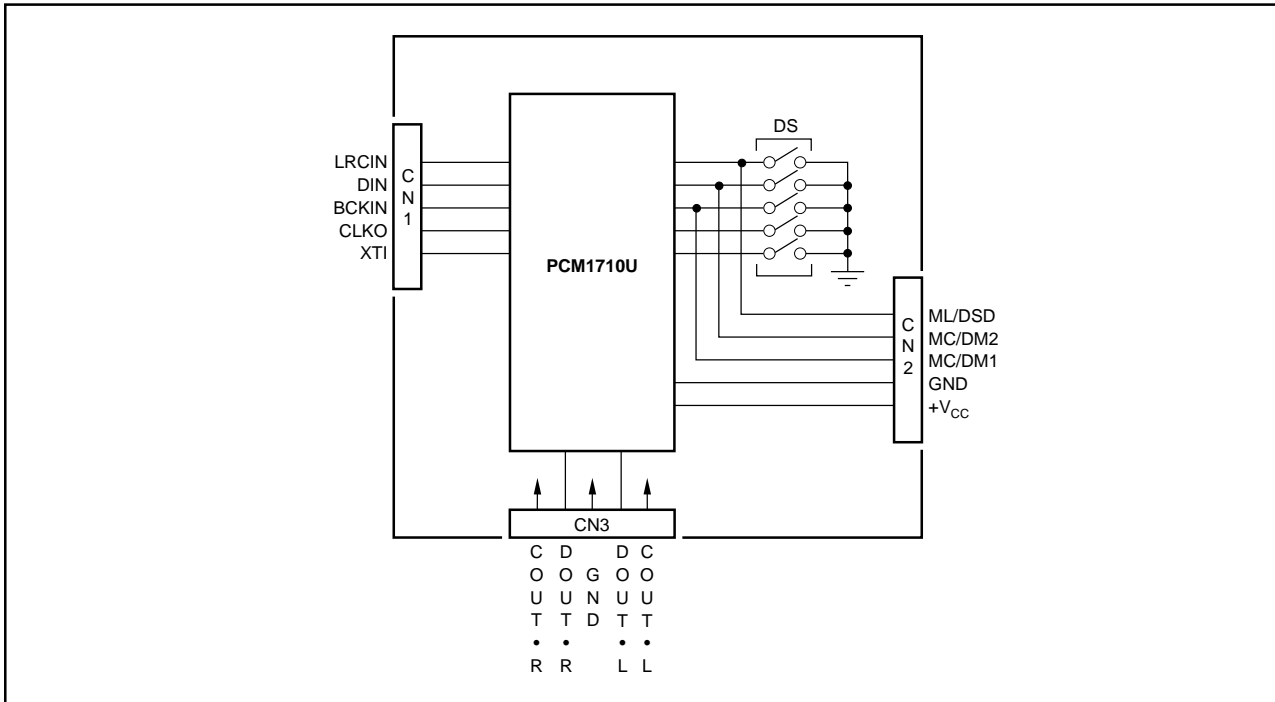

COMPONENT LOCATION AND FUNCTION

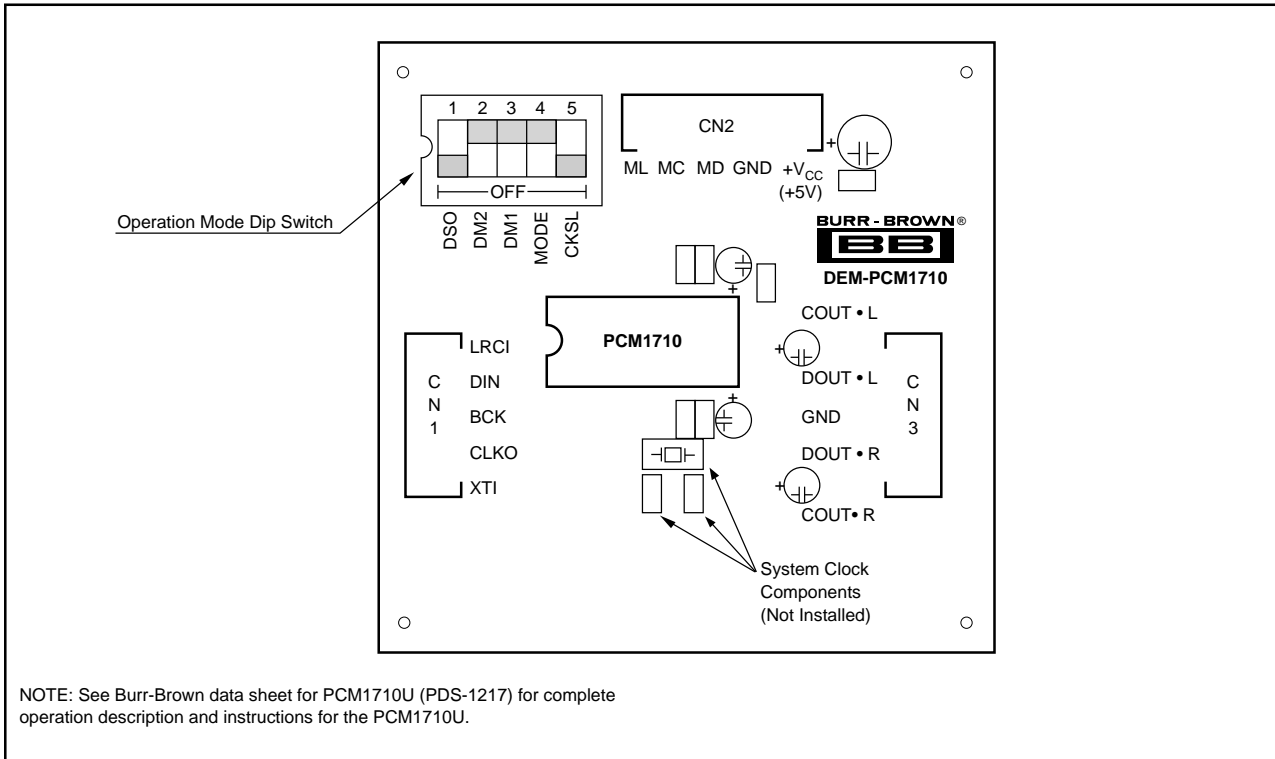

CIRCUIT DIAGRAM

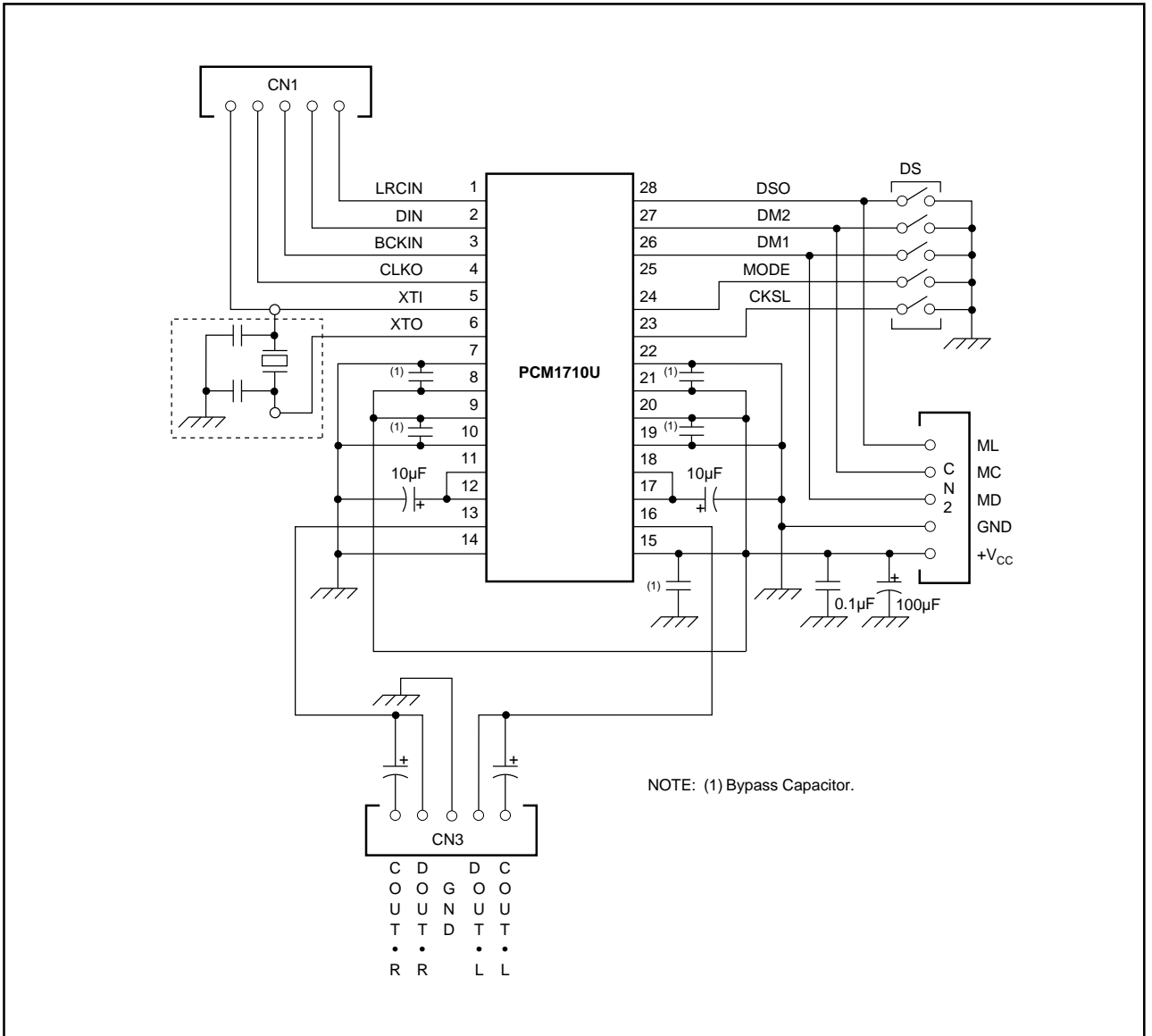

PATTERN LAYOUT

TOP

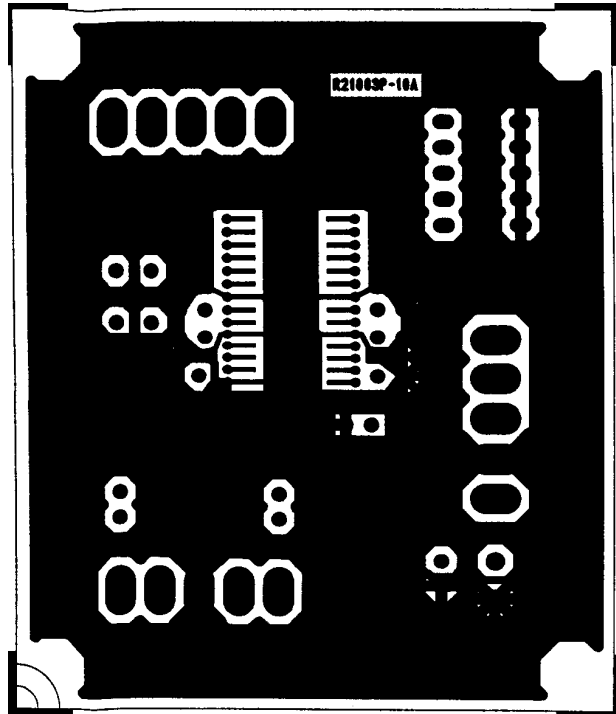

BOTTOM

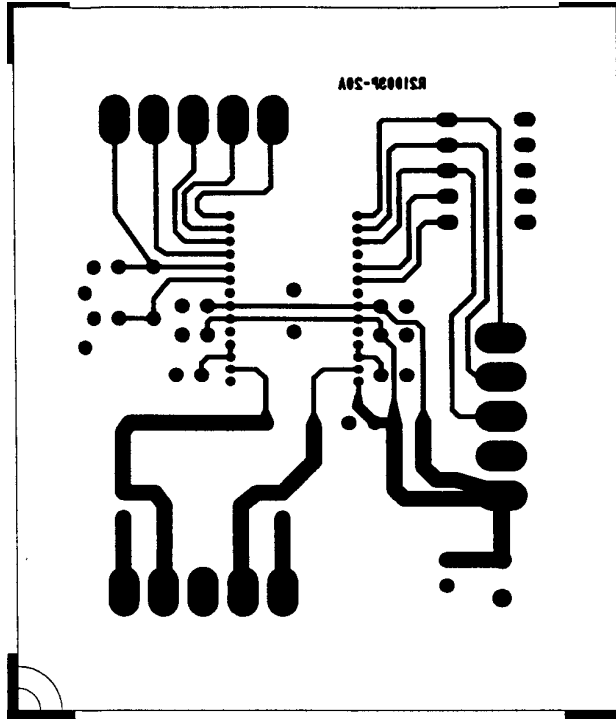

IMPORTANT NOTICE

Texas Instruments and its subsidiaries (TI) reserve the right to make changes to their products or to discontinue any product or service without notice, and advise customers to obtain the latest version of relevant information to verify, before placing orders, that information being relied on is current and complete. All products are sold subject to the terms and conditions of sale supplied at the time of order acknowledgment, including those pertaining to warranty, patent infringement, and limitation of liability.

TI warrants performance of its semiconductor products to the specifications applicable at the time of sale in accordance with TI's standard warranty. Testing and other quality control techniques are utilized to the extent TI deems necessary to support this warranty. Specific testing of all parameters of each device is not necessarily performed, except those mandated by government requirements.

Customers are responsible for their applications using TI components.

In order to minimize risks associated with the customer's applications, adequate design and operating safeguards must be provided by the customer to minimize inherent or procedural hazards.

TI assumes no liability for applications assistance or customer product design. TI does not warrant or represent that any license, either express or implied, is granted under any patent right, copyright, mask work right, or other intellectual property right of TI covering or relating to any combination, machine, or process in which such semiconductor products or services might be or are used. TI's publication of information regarding any third party's products or services does not constitute TI's approval, warranty or endorsement thereof.