

DATA SHEET

PCF8576C

Universal LCD driver for low
multiplex rates

Product specification
Supersedes data of 1995 Jun 30
File under Integrated Circuits, IC12

1996 Dec 09

Universal LCD driver for low multiplex rates

PCF8576C

FEATURES

- Single-chip LCD controller/driver
- Selectable backplane drive configuration: static or 2/3/4 backplane multiplexing
- Selectable display bias configuration: static, 1/2 or 1/3
- Internal LCD bias generation with voltage-follower buffers
- 40 segment drives: up to twenty 8-segment numeric characters; up to ten 15-segment alphanumeric characters; or any graphics of up to 160 elements
- 40 × 4-bit RAM for display data storage
- Auto-incremented display data loading across device subaddress boundaries
- Display memory bank switching in static and duplex drive modes
- Versatile blinking modes
- LCD and logic supplies may be separated
- Wide power supply range: from 2 V for low-threshold LCDs and up to 6 V for guest-host LCDs and high-threshold (automobile) twisted nematic LCDs.
A 9 V version is also available on request.
- Low power consumption
- Power-saving mode for extremely low power consumption in battery-operated and telephone applications
- I²C-bus interface
- TTL/CMOS compatible
- Compatible with any 4-bit, 8-bit or 16-bit microprocessors/microcontrollers



- May be cascaded for large LCD applications (up to 2560 segments possible)
- Cascadable with 24-segment LCD driver PCF8566
- Optimized pinning for plane wiring in both and multiple PCF8576C applications
- Space-saving 56-lead plastic very small outline package (VSO56) or 64-lead low profile quad flat package (LQFP64)
- No external components
- Compatible with chip-on-glass technology
- Manufactured in silicon gate CMOS process.

GENERAL DESCRIPTION

The PCF8576C is a peripheral device which interfaces to almost any Liquid Crystal Display (LCD) with low multiplex rates. It generates the drive signals for any static or multiplexed LCD containing up to four backplanes and up to 40 segments and can easily be cascaded for larger LCD applications. The PCF8576C is compatible with most microprocessors/microcontrollers and communicates via a two-line bidirectional I²C-bus. Communication overheads are minimized by a display RAM with auto-incremented addressing, by hardware subaddressing and by display memory switching (static and duplex drive modes).

ORDERING INFORMATION

| TYPE NUMBER | PACKAGE | | |
|--------------|---------|--|----------|
| | NAME | DESCRIPTION | VERSION |
| PCF8576CT | VSO56 | plastic very small outline package; 56 leads | SOT190-1 |
| PCF8576CU | – | uncased chip in tray | – |
| PCF8576CU/10 | FFC | chip-on-film frame carrier | – |
| PCF8576CH | LQFP64 | plastic low profile quad flat package; 64 leads; body 10 × 10 × 1.4 mm | SOT314-2 |

Universal LCD driver for low multiplex rates

PCF8576C

BLOCK DIAGRAM

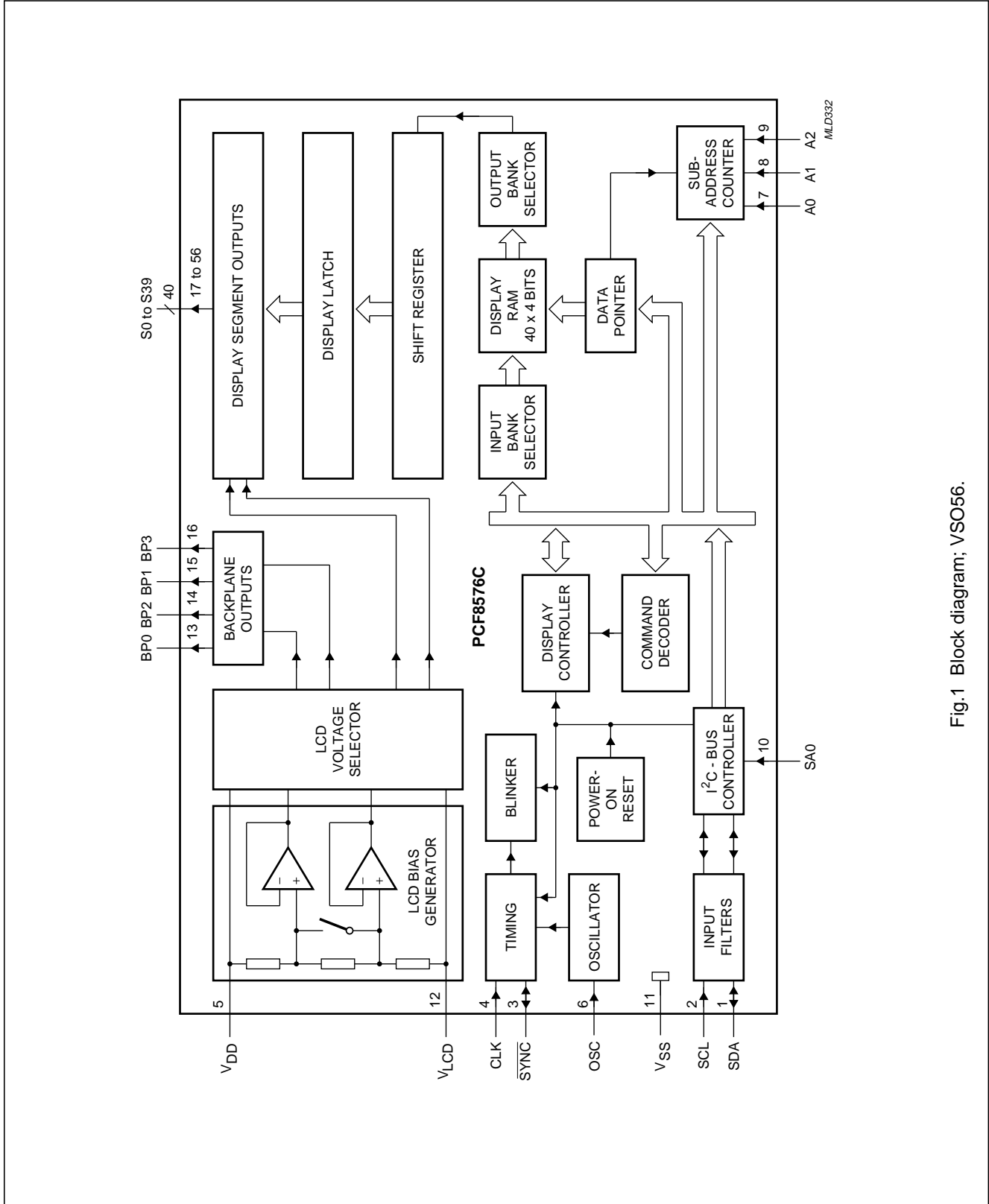

Fig.1 Block diagram; VSO56.

Universal LCD driver for low multiplex rates

PCF8576C

PINNING

| SYMBOL | PIN | | DESCRIPTION |
|--------------------------|----------|--------------------------------------|---|
| | SOT190 | SOT314 | |
| SDA | 1 | 10 | I ² C-bus serial data input/output |
| SCL | 2 | 11 | I ² C-bus serial clock input |
| $\overline{\text{SYNC}}$ | 3 | 12 | cascade synchronization input/output |
| CLK | 4 | 13 | external clock input |
| V _{DD} | 5 | 14 | supply voltage |
| OSC | 6 | 15 | oscillator input |
| A0 to A2 | 7 to 9 | 16 to 18 | I ² C-bus subaddress inputs |
| SA0 | 10 | 19 | I ² C-bus slave address input; bit 0 |
| V _{SS} | 11 | 20 | logic ground |
| V _{LCD} | 12 | 21 | LCD supply voltage |
| BP0, BP2, BP1, BP3 | 13 to 16 | 25 to 28 | LCD backplane outputs |
| S0 to S39 | 17 to 56 | 29 to 32, 34 to 47, 49 to 64, 2 to 7 | LCD segment outputs |
| n.c. | – | 1, 8, 9, 22 to 24, 33 and 48 | not connected |

Universal LCD driver for low multiplex rates

PCF8576C

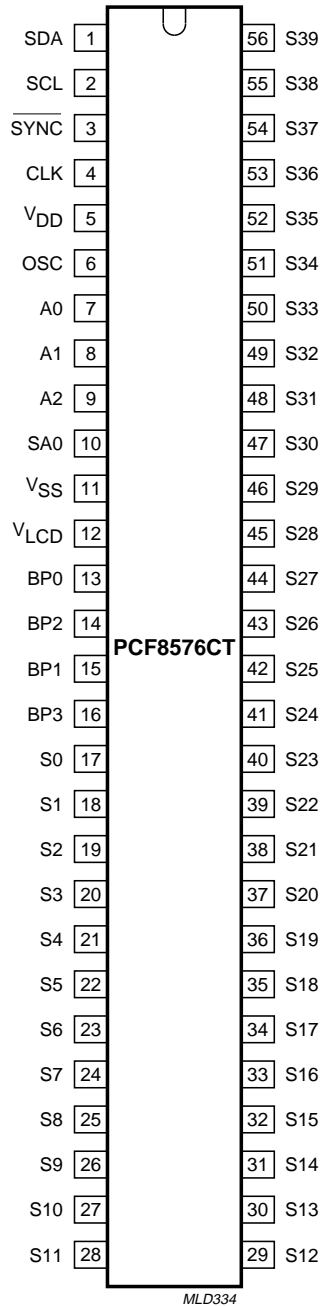

Fig.2 Pin configuration; VSO56.

Universal LCD driver for low multiplex rates

PCF8576C

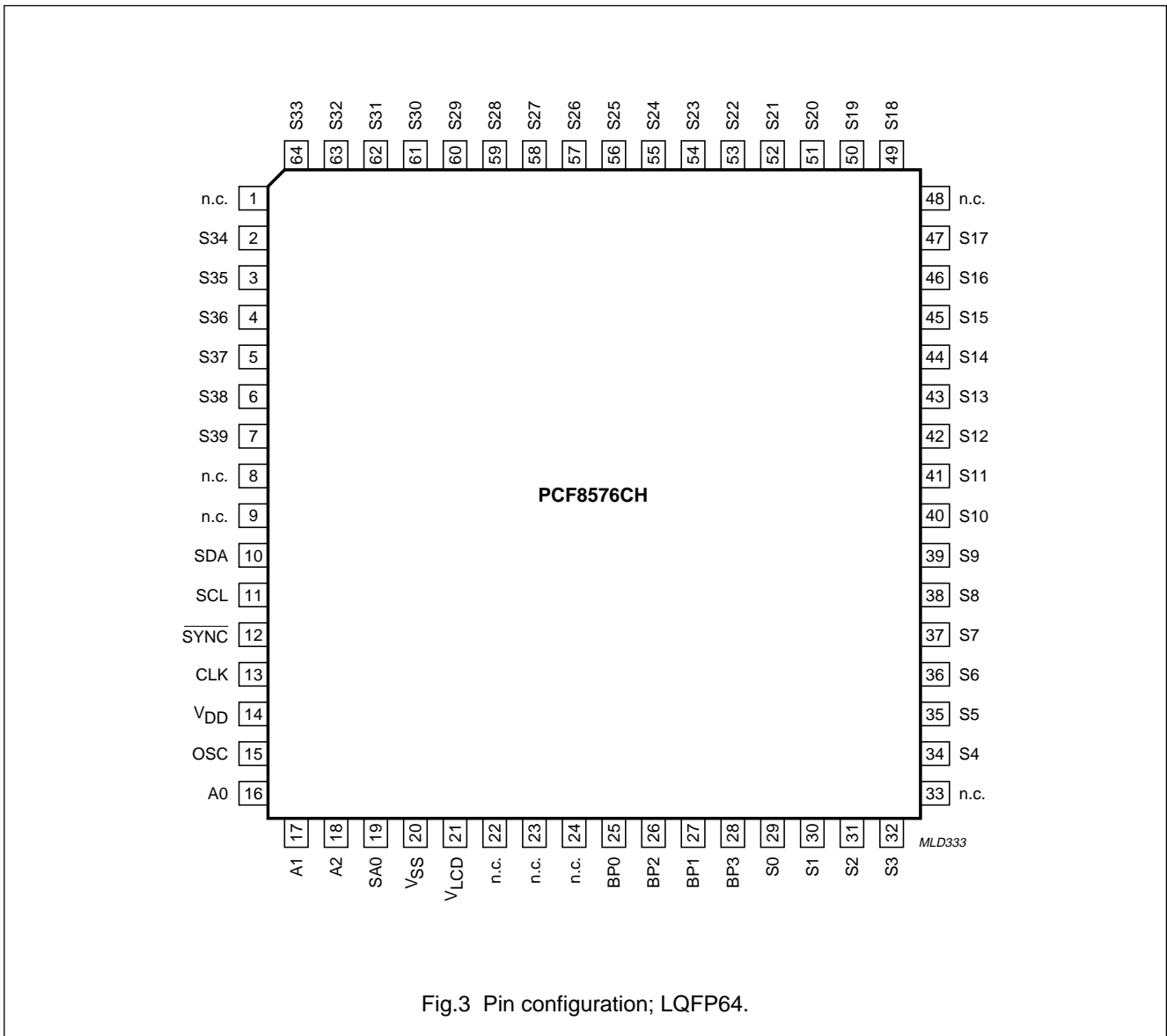

Fig.3 Pin configuration; LQFP64.

Universal LCD driver for low multiplex rates

PCF8576C

FUNCTIONAL DESCRIPTION

The PCF8576C is a versatile peripheral device designed to interface to any microprocessor/microcontroller to a wide variety of LCDs. It can directly drive any static or multiplexed LCD containing up to four backplanes and up to 40 segments. The display configurations possible with the PCF8576C depend on the number of active backplane outputs required; a selection of display configurations is given in Table 1.

The host microprocessor/microcontroller maintains the 2-line I²C-bus communication channel with the PCF8576C. The internal oscillator is selected by tying OSC (pin 6) to V_{SS} (pin 11). The appropriate biasing voltages for the multiplexed LCD waveforms are generated internally. The only other connections required to complete the system are to the power supplies (V_{DD}, V_{SS} and V_{LCD}) and the LCD panel chosen for the application.

All of the display configurations given in Table 1 can be implemented in the typical system shown in Fig.4.

Table 1 Selection of display configurations

| NUMBER OF | | 7-SEGMENTS NUMERIC | | 14-SEGMENTS ALPHANUMERIC | | DOT MATRIX |
|------------|----------|--------------------|-------------------|--------------------------|-------------------|-------------------|
| BACKPLANES | SEGMENTS | DIGITS | INDICATOR SYMBOLS | CHARACTERS | INDICATOR SYMBOLS | |
| 4 | 160 | 20 | 20 | 10 | 20 | 160 dots (4 × 40) |
| 3 | 120 | 15 | 15 | 8 | 8 | 120 dots (3 × 40) |
| 2 | 80 | 10 | 10 | 5 | 10 | 80 dots (2 × 40) |
| 1 | 40 | 5 | 5 | 2 | 12 | 40 dots (1 × 40) |

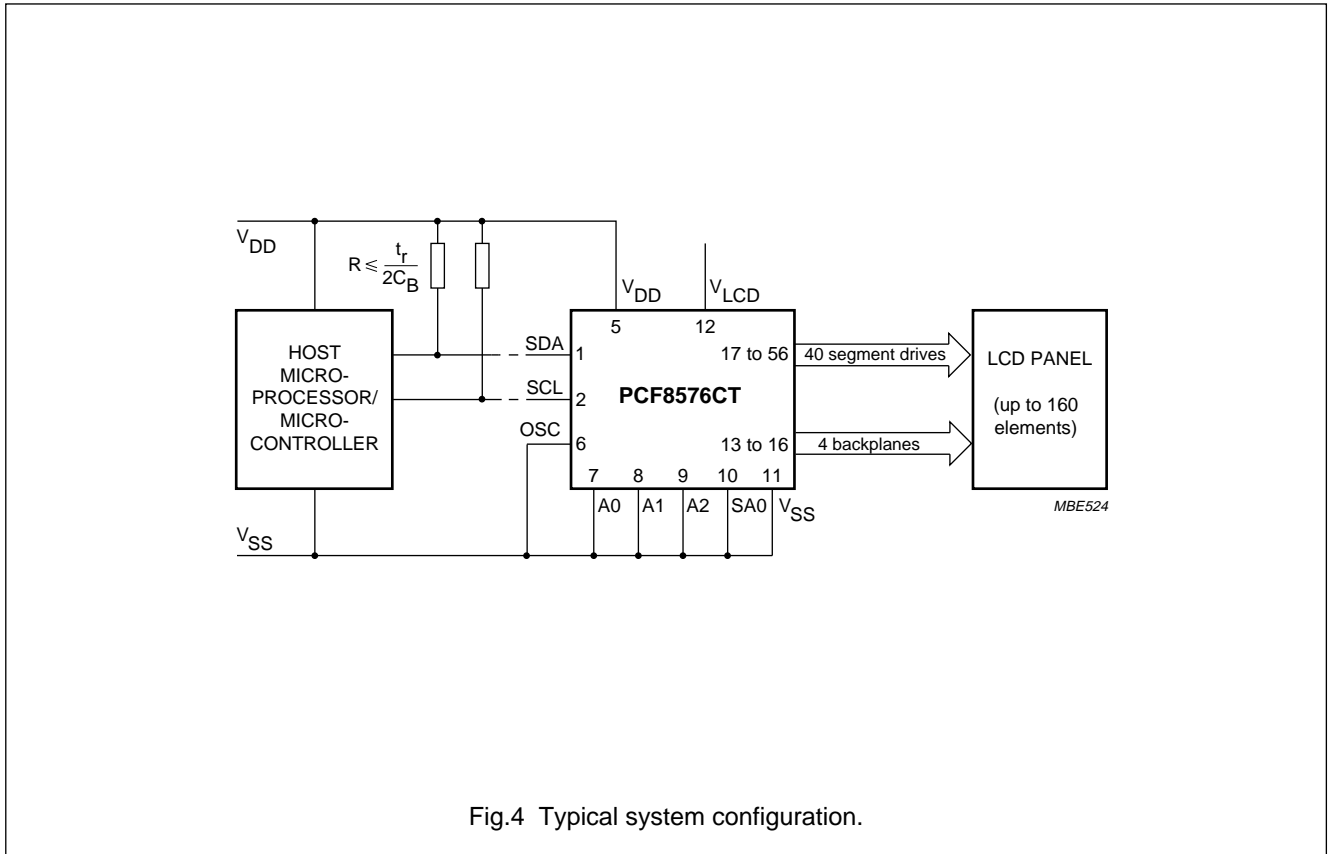

Fig.4 Typical system configuration.

Universal LCD driver for low multiplex rates

PCF8576C

Power-on reset

At power-on the PCF8576C resets to a starting condition as follows:

1. All backplane outputs are set to V_{DD} .
2. All segment outputs are set to V_{DD} .
3. The drive mode '1 : 4 multiplex with $\frac{1}{3}$ bias' is selected.
4. Blinking is switched off.
5. Input and output bank selectors are reset (as defined in Table 5).
6. The I²C-bus interface is initialized.
7. The data pointer and the subaddress counter are cleared.

Data transfers on the I²C-bus should be avoided for 1 ms following power-on to allow completion of the reset action.

LCD bias generator

The full-scale LCD voltage (V_{op}) is obtained from $V_{DD} - V_{LCD}$. The LCD voltage may be temperature compensated externally through the V_{LCD} supply to pin 12. Fractional LCD biasing voltages are obtained from an internal voltage divider of the three series resistors connected between V_{DD} and V_{LCD} . The centre resistor can be switched out of the circuit to provide a $\frac{1}{2}$ bias voltage level for the 1 : 2 multiplex configuration.

LCD voltage selector

The LCD voltage selector co-ordinates the multiplexing of the LCD in accordance with the selected LCD drive configuration. The operation of the voltage selector is controlled by MODE SET commands from the command decoder. The biasing configurations that apply to the preferred modes of operation, together with the biasing characteristics as functions of $V_{op} = V_{DD} - V_{LCD}$ and the resulting discrimination ratios (D), are given in Table 2.

A practical value for V_{op} is determined by equating $V_{off(rms)}$ with a defined LCD threshold voltage (V_{th}), typically when the LCD exhibits approximately 10% contrast. In the static drive mode a suitable choice is $V_{op} > 3V_{th}$ approximately.

Multiplex drive ratios of 1 : 3 and 1 : 4 with $\frac{1}{2}$ bias are possible but the discrimination and hence the contrast ratios are smaller ($\sqrt{3} = 1.732$ for 1 : 3 multiplex or

$$\frac{\sqrt{21}}{3} = 1.528 \text{ for 1 : 4 multiplex}).$$

The advantage of these modes is a reduction of the LCD full-scale voltage V_{op} as follows:

- 1 : 3 multiplex ($\frac{1}{2}$ bias):

$$V_{op} = \sqrt{6} \times V_{off(rms)} = 2.449 V_{off(rms)}$$

- 1 : 4 multiplex ($\frac{1}{2}$ bias):

$$V_{op} = \left[\frac{(4 \times \sqrt{3})}{3} \right] = 2.309 V_{off(rms)}$$

These compare with $V_{op} = 3 V_{off(rms)}$ when $\frac{1}{3}$ bias is used.

Table 2 Preferred LCD drive modes: summary of characteristics

| LCD DRIVE MODE | NUMBER OF | | LCD BIAS CONFIGURATION | $\frac{V_{off(rms)}}{V_{op}}$ | $\frac{V_{on(rms)}}{V_{op}}$ | $D = \frac{V_{on(rms)}}{V_{off(rms)}}$ |
|----------------|------------|--------|------------------------|-------------------------------|------------------------------|--|
| | BACKPLANES | LEVELS | | | | |
| static | 1 | 2 | static | 0 | 1 | ∞ |
| 1 : 2 | 2 | 3 | $\frac{1}{2}$ | 0.354 | 0.791 | 2.236 |
| 1 : 2 | 2 | 4 | $\frac{1}{3}$ | 0.333 | 0.745 | 2.236 |
| 1 : 3 | 3 | 4 | $\frac{1}{3}$ | 0.333 | 0.638 | 1.915 |
| 1 : 4 | 4 | 4 | $\frac{1}{3}$ | 0.333 | 0.577 | 1.732 |

Universal LCD driver for low multiplex rates

PCF8576C

LCD drive mode waveforms

STATIC DRIVE MODE

The static LCD drive mode is used when a single backplane is provided in the LCD. Backplane and segment drive waveforms for this mode are shown in Fig.5.

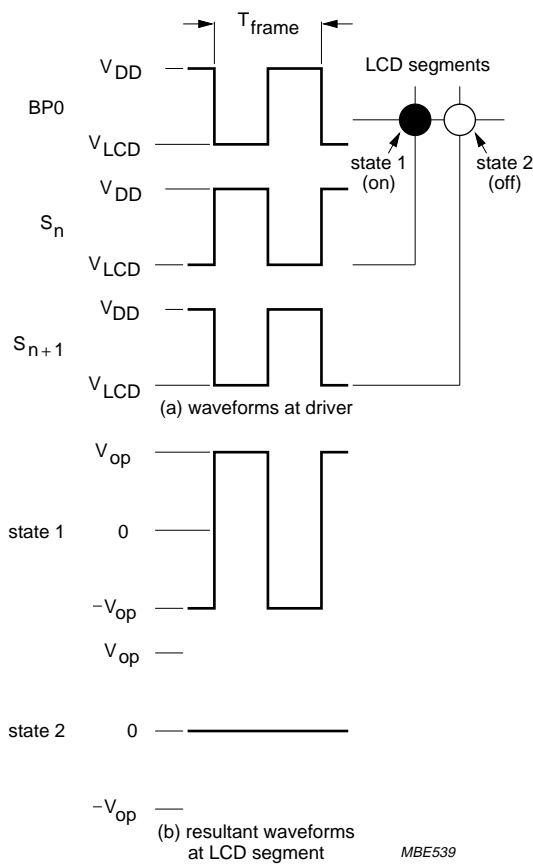

MBE539

$$V_{state1}(t) = V_{S_n}(t) - V_{BP0}(t)$$

$$V_{on(rms)} = V_{op}$$

$$V_{state2}(t) = V_{S_{n+1}}(t) - V_{BP0}(t)$$

$$V_{off(rms)} = 0 \text{ V}$$

Fig.5 Static drive mode waveforms ($V_{op} = V_{DD} - V_{LCD}$).

Universal LCD driver for low multiplex rates

PCF8576C

1 : 2 MULTIPLEX DRIVE MODE

When two backplanes are provided in the LCD, the 1 : 2 multiplex mode applies. The PCF8576C allows use of 1/2 bias or 1/3 bias in this mode as shown in Figs 6 and 7.

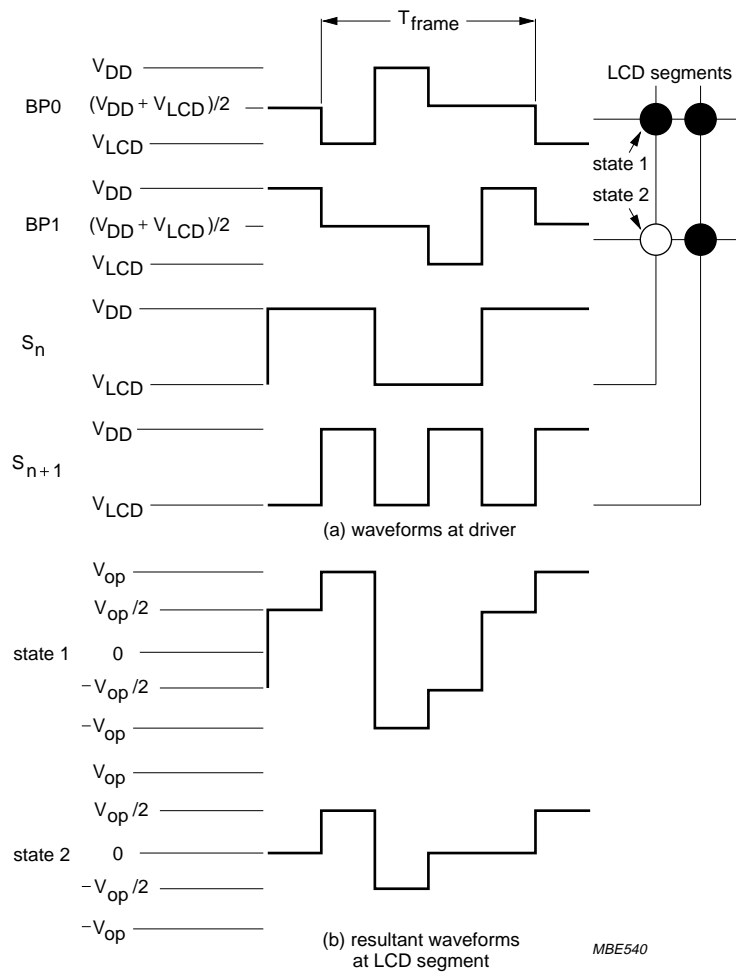

$$V_{state1}(t) = V_{S_n}(t) - V_{BP0}(t)$$

$$V_{on(rms)} = 0.791 V_{op}$$

$$V_{state2}(t) = V_{S_n}(t) - V_{BP1}(t)$$

$$V_{off(rms)} = 0.354 V_{op}$$

Fig.6 Waveforms for the 1 : 2 multiplex drive mode with 1/2 bias (V_{op} = V_{DD} - V_{LCD}).

Universal LCD driver for low multiplex rates

PCF8576C

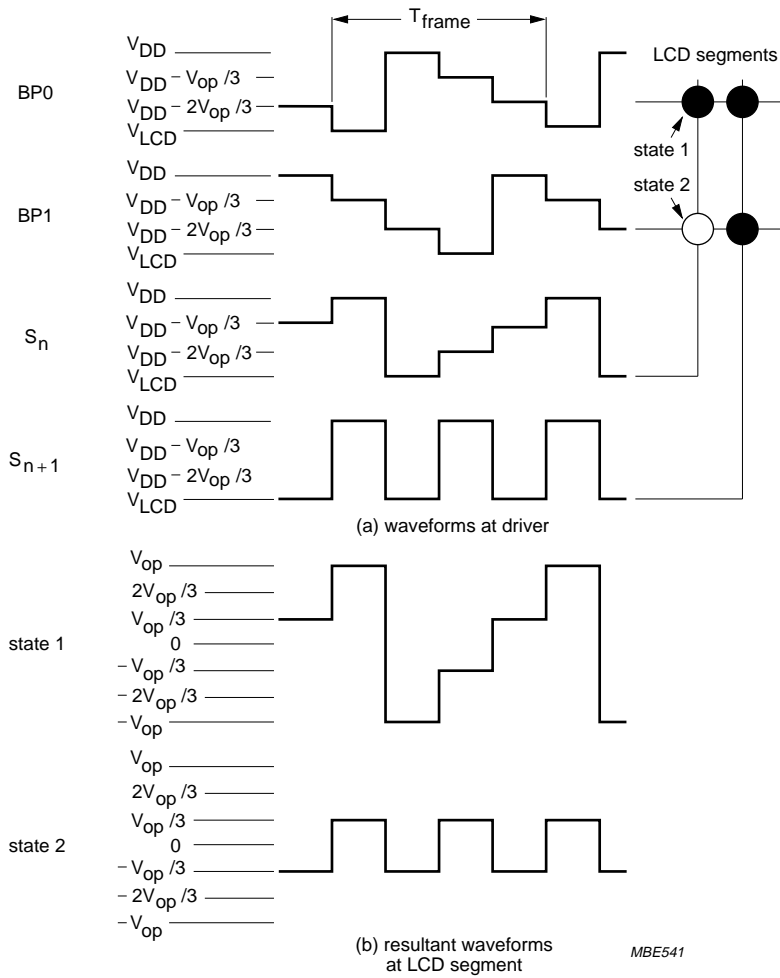

$$V_{state1}(t) = V_{S_n}(t) - V_{BP0}(t)$$

$$V_{on(rms)} = 0.745V_{op}$$

$$V_{state2}(t) = V_{S_n}(t) - V_{BP1}(t)$$

$$V_{off(rms)} = 0.333V_{op}$$

Fig.7 Waveforms for the 1 : 2 multiplex drive mode with 1/3 bias ($V_{op} = V_{DD} - V_{LCD}$).

Universal LCD driver for low multiplex rates

PCF8576C

1 : 3 MULTIPLEX DRIVE MODE

When three backplanes are provided in the LCD, the 1 : 3 multiplex drive mode applies, as shown in Fig.8.

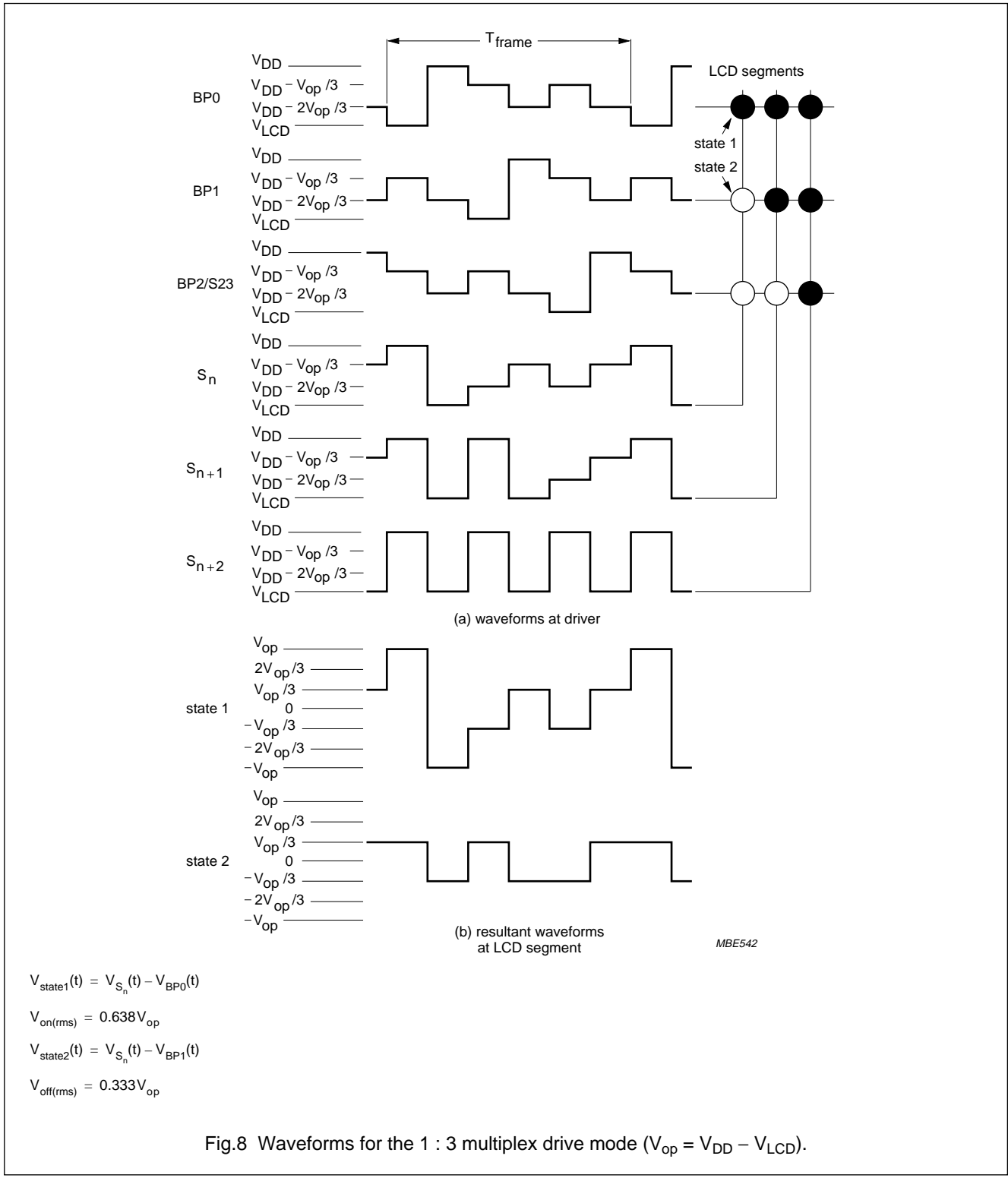

Universal LCD driver for low multiplex rates

PCF8576C

1 : 4 MULTIPLEX DRIVE MODE

When four backplanes are provided in the LCD, the 1 : 4 multiplex drive mode applies, as shown in Fig.9.

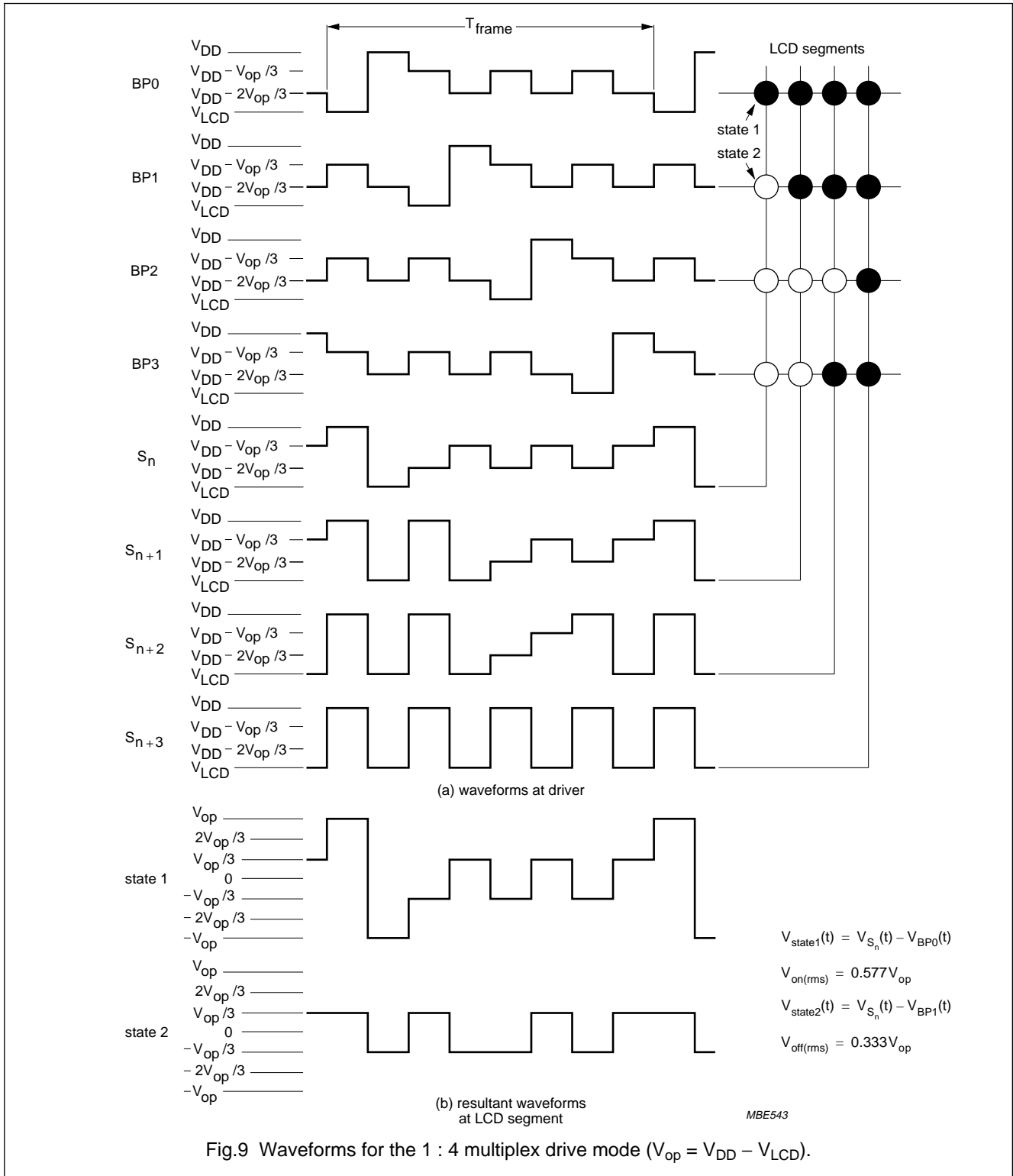

Fig.9 Waveforms for the 1 : 4 multiplex drive mode (V_{op} = V_{DD} - V_{LCD}).

Universal LCD driver for low multiplex rates

PCF8576C

Oscillator

INTERNAL CLOCK

The internal logic and the LCD drive signals of the PCF8576C are timed either by the built-in oscillator or from an external clock. When the internal oscillator is used, OSC (pin 6) should be connected to V_{SS} (pin 11). In this event, the output from CLK (pin 4) provides the clock signal for cascaded PCF8566s or PCF8576Cs in the system.

Note that the PCF8576C is backwards compatible with the PCF8576. Where resistor R_{osc} to V_{SS} is present, the internal oscillator is selected.

EXTERNAL CLOCK

The condition for external clock is made by tying OSC (pin 6) to V_{DD} ; CLK (pin 4) then becomes the external clock input.

The clock frequency (f_{clk}) determines the LCD frame frequency and the maximum rate for data reception from the I²C-bus. To allow I²C-bus transmissions at their maximum data rate of 100 kHz, f_{clk} should be chosen to be above 125 kHz.

A clock signal must always be supplied to the device; removing the clock may freeze the LCD in a DC state.

Timing

The timing of the PCF8576C organizes the internal data flow of the device. This includes the transfer of display data from the display RAM to the display segment outputs. In cascaded applications, the synchronization signal SYNC maintains the correct timing relationship between the PCF8576Cs in the system. The timing also generates the LCD frame frequency which it derives as an integer multiple of the clock frequency (see Table 3). The frame frequency is set by the MODE SET commands when internal clock is used, or by the frequency applied to pin 4 when external clock is used.

The ratio between the clock frequency and the LCD frame frequency depends on the mode in which the device is operating. In the power-saving mode the reduction ratio is six times smaller; this allows the clock frequency to be reduced by a factor of six. The reduced clock frequency results in a significant reduction in power dissipation. The lower clock frequency has the disadvantage of increasing the response time when large amounts of display data are transmitted on the I²C-bus.

When a device is unable to digest a display data byte before the next one arrives, it holds the SCL line LOW until the first display data byte is stored. This slows down the transmission rate of the I²C-bus but no data loss occurs.

Display latch

The display latch holds the display data while the corresponding multiplex signals are generated. There is a one-to-one relationship between the data in the display latch, the LCD segment outputs and one column of the display RAM.

Shift register

The shift register serves to transfer display information from the display RAM to the display latch while previous data is displayed.

Segment outputs

The LCD drive section includes 40 segment outputs S0 to S39 (pins 17 to 56) which should be connected directly to the LCD. The segment output signals are generated in accordance with the multiplexed backplane signals and with data resident in the display latch. When less than 40 segment outputs are required the unused segment outputs should be left open-circuit.

Backplane outputs

The LCD drive section includes four backplane outputs BP0 to BP3 which should be connected directly to the LCD. The backplane output signals are generated in accordance with the selected LCD drive mode. If less than four backplane outputs are required the unused outputs can be left open-circuit. In the 1 : 3 multiplex drive mode BP3 carries the same signal as BP1, therefore these two adjacent outputs can be tied together to give enhanced drive capabilities. In the 1 : 2 multiplex drive mode BP0 and BP2, BP1 and BP3 respectively carry the same signals and may also be paired to increase the drive capabilities. In the static drive mode the same signal is carried by all four backplane outputs and they can be connected in parallel for very high drive requirements.

Universal LCD driver for low multiplex rates

PCF8576C

Display RAM

The display RAM is a static 40 × 4-bit RAM which stores LCD data. A logic 1 in the RAM bit-map indicates the on state of the corresponding LCD segment; similarly, a logic 0 indicates the off state. There is a one-to-one correspondence between the RAM addresses and the segment outputs, and between the individual bits of a RAM word and the backplane outputs. The first RAM column corresponds to the 40 segments operated with respect to backplane BP0 (see Fig.10). In multiplexed LCD applications the segment data of the second, third and fourth column of the display RAM are time-multiplexed with BP1, BP2 and BP3 respectively.

When display data is transmitted to the PCF8576C the display bytes received are stored in the display RAM in accordance with the selected LCD drive mode. To illustrate the filling order, an example of a 7-segment numeric display showing all drive modes is given in Fig.11; the RAM filling organization depicted applies equally to other LCD types.

With reference to Fig.11, in the static drive mode the eight transmitted data bits are placed in bit 0 of eight successive display RAM addresses.

In the 1 : 2 multiplex drive mode the eight transmitted data bits are placed in bits 0 and 1 of four successive display RAM addresses. In the 1 : 3 multiplex drive mode these bits are placed in bits 0, 1 and 2 of three successive addresses, with bit 2 of the third address left unchanged. This last bit may, if necessary, be controlled by an additional transfer to this address but care should be taken to avoid overriding adjacent data because full bytes are always transmitted. In the 1 : 4 multiplex drive mode the eight transmitted data bits are placed in bits 0, 1, 2 and 3 of two successive display RAM addresses.

Table 3 LCD frame frequencies

| PCF8576C MODE | FRAME FREQUENCY | NOMINAL FRAME FREQUENCY (Hz) |
|-------------------|------------------------|------------------------------|
| Normal mode | $\frac{f_{clk}}{2880}$ | 64 |
| Power-saving mode | $\frac{f_{clk}}{480}$ | 64 |

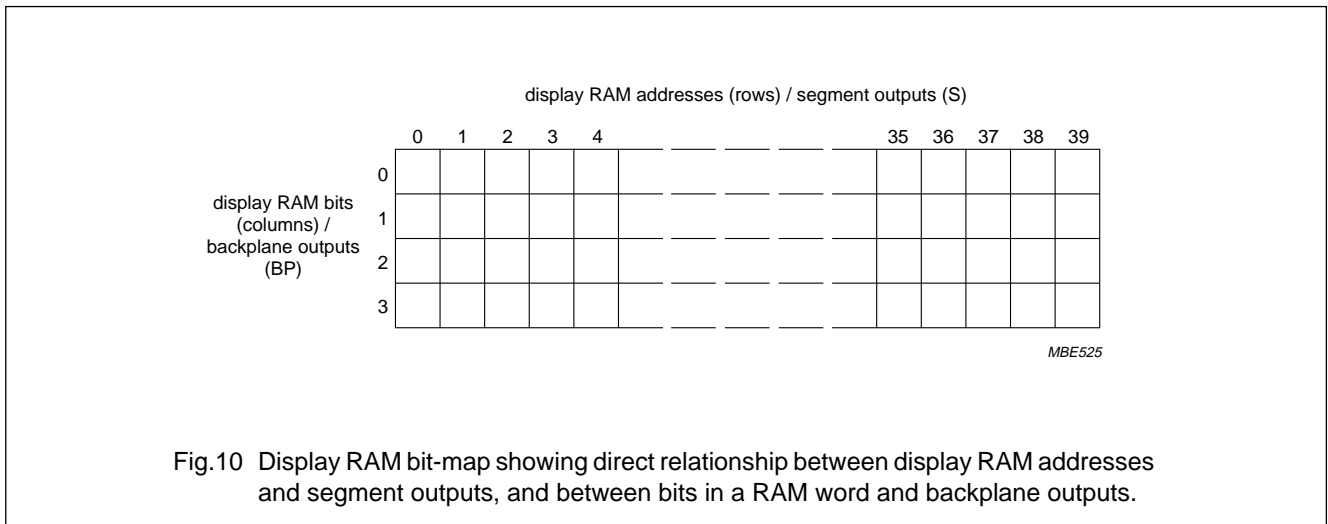

Universal LCD driver for low multiplex rates

PCF8576C

Data pointer

The addressing mechanism for the display RAM is realized using the data pointer. This allows the loading of an individual display data byte, or a series of display data bytes, into any location of the display RAM. The sequence commences with the initialization of the data pointer by the LOAD DATA POINTER command. Following this, an arriving data byte is stored starting at the display RAM address indicated by the data pointer thereby observing the filling order shown in Fig.11. The data pointer is automatically incremented in accordance with the chosen LCD configuration. That is, after each byte is stored, the contents of the data pointer are incremented by eight (static drive mode), by four (1 : 2 multiplex drive mode) or by two (1 : 2 multiplex drive mode).

Subaddress counter

The storage of display data is conditioned by the contents of the subaddress counter. Storage is allowed to take place only when the contents of the subaddress counter agree with the hardware subaddress applied to A0, A1 and A2. The subaddress counter value is defined by the DEVICE SELECT command. If the contents of the subaddress counter and the hardware subaddress do not agree then data storage is inhibited but the data pointer is incremented as if data storage had taken place. The subaddress counter is also incremented when the data pointer overflows.

The storage arrangements described lead to extremely efficient data loading in cascaded applications. When a series of display bytes are sent to the display RAM, automatic wrap-over to the next PCF8576C occurs when the last RAM address is exceeded. Subaddressing across device boundaries is successful even if the change to the next device in the cascade occurs within a transmitted character (such as during the 14th display data byte transmitted in 1 : 3 multiplex mode).

Output bank selector

This selects one of the four bits per display RAM address for transfer to the display latch. The actual bit chosen depends on the particular LCD drive mode in operation and on the instant in the multiplex sequence. In 1 : 4 multiplex, all RAM addresses of bit 0 are the first to be selected, these are followed by the contents of bit 1, bit 2 and then bit 3. Similarly in 1 : 3 multiplex, bits 0, 1 and 2 are selected sequentially. In 1 : 2 multiplex, bits 0 and 1 are selected and, in the static mode, bit 0 is selected.

The PCF8576C includes a RAM bank switching feature in the static and 1 : 2 multiplex drive modes. In the static drive mode, the BANK SELECT command may request the contents of bit 2 to be selected for display instead of bit 0 contents. In the 1 : 2 drive mode, the contents of bits 2 and 3 may be selected instead of bits 0 and 1. This gives the provision for preparing display information in an alternative bank and to be able to switch to it once it is assembled.

Input bank selector

The input bank selector loads display data into the display RAM in accordance with the selected LCD drive configuration. Display data can be loaded in bit 2 in static drive mode or in bits 2 and 3 in 1 : 2 drive mode by using the BANK SELECT command. The input bank selector functions independent of the output bank selector.

Universal LCD driver for low multiplex rates

PCF8576C

Blinker

The display blinking capabilities of the PCF8576C are very versatile. The whole display can be blinked at frequencies selected by the BLINK command. The blinking frequencies are integer multiples of the clock frequency; the ratios between the clock and blinking frequencies depend on the mode in which the device is operating, as shown in Table 4.

An additional feature is for an arbitrary selection of LCD segments to be blinked. This applies to the static and 1 : 2 LCD drive modes and can be implemented without any communication overheads.

By means of the output bank selector, the displayed RAM banks are exchanged with alternate RAM banks at the blinking frequency. This mode can also be specified by the BLINK command.

In the 1 : 3 and 1 : 4 multiplex modes, where no alternate RAM bank is available, groups of LCD segments can be blinked by selectively changing the display RAM data at fixed time intervals.

If the entire display is to be blinked at a frequency other than the nominal blinking frequency, this can be effectively performed by resetting and setting the display enable bit E at the required rate using the MODE SET command.

Table 4 Blinking frequencies

| BLINKING MODE | NORMAL OPERATING MODE RATIO | POWER-SAVING MODE RATIO | NOMINAL BLINKING FREQUENCY |
|---------------|-----------------------------|-------------------------|----------------------------|
| Off | – | – | blinking off |
| 2 Hz | $\frac{f_{clk}}{92160}$ | $\frac{f_{clk}}{15360}$ | 2 Hz |
| 1 Hz | $\frac{f_{clk}}{184320}$ | $\frac{f_{clk}}{30720}$ | 1 Hz |
| 0.5 Hz | $\frac{f_{clk}}{368640}$ | $\frac{f_{clk}}{61440}$ | 0.5 Hz |

Universal LCD driver for low multiplex rates

PCF8576C

| drive mode | LCD segments | LCD backplanes | display RAM filling order | transmitted display byte | | | | | | | | | | | | | | | | | | | | | | | | | | | | | | | | | | | | | | | | | | | | | | | | | | | | | | | | | | | | | | | | | | | | | | | | |
|--------------------|--------------|----------------|---|--------------------------|-----|-----|-----|-----|-----|-----|-----|--------|---|---|---|---|-----|---|---|--|---|---|---|---|-----|---|---|--|----|---|---|----|-----|---|---|--|---|---|---|---|-----|---|---|--|---|----|---|---|-----|---|---|--|-----|--|--|--|-----|--|----|--|-----|----|---|----|-----|---|---|----|---|---|---|---|---|---|---|----|
| static | | | <table border="1"> <tr> <td>n</td> <td>n+1</td> <td>n+2</td> <td>n+3</td> <td>n+4</td> <td>n+5</td> <td>n+6</td> <td>n+7</td> </tr> <tr> <td>bit/BP</td> <td>0</td> <td>1</td> <td>2</td> <td>3</td> <td>x</td> <td>x</td> <td>x</td> </tr> <tr> <td></td> <td>c</td> <td>b</td> <td>a</td> <td>f</td> <td>g</td> <td>e</td> <td>d</td> </tr> <tr> <td></td> <td>x</td> <td>x</td> <td>x</td> <td>x</td> <td>x</td> <td>x</td> <td>x</td> </tr> <tr> <td></td> <td>x</td> <td>x</td> <td>x</td> <td>x</td> <td>x</td> <td>x</td> <td>x</td> </tr> <tr> <td></td> <td>x</td> <td>x</td> <td>x</td> <td>x</td> <td>x</td> <td>x</td> <td>x</td> </tr> <tr> <td></td> <td></td> <td></td> <td></td> <td></td> <td></td> <td></td> <td>DP</td> </tr> </table> | n | n+1 | n+2 | n+3 | n+4 | n+5 | n+6 | n+7 | bit/BP | 0 | 1 | 2 | 3 | x | x | x | | c | b | a | f | g | e | d | | x | x | x | x | x | x | x | | x | x | x | x | x | x | x | | x | x | x | x | x | x | x | | | | | | | | DP | <table border="1"> <tr> <td colspan="4">MSB</td> <td colspan="4">LSB</td> </tr> <tr> <td>c</td> <td>b</td> <td>a</td> <td>f</td> <td>g</td> <td>e</td> <td>d</td> <td>DP</td> </tr> </table> | MSB | | | | LSB | | | | c | b | a | f | g | e | d | DP |
| n | n+1 | n+2 | n+3 | n+4 | n+5 | n+6 | n+7 | | | | | | | | | | | | | | | | | | | | | | | | | | | | | | | | | | | | | | | | | | | | | | | | | | | | | | | | | | | | | | | | | | | | | |
| bit/BP | 0 | 1 | 2 | 3 | x | x | x | | | | | | | | | | | | | | | | | | | | | | | | | | | | | | | | | | | | | | | | | | | | | | | | | | | | | | | | | | | | | | | | | | | | | |
| | c | b | a | f | g | e | d | | | | | | | | | | | | | | | | | | | | | | | | | | | | | | | | | | | | | | | | | | | | | | | | | | | | | | | | | | | | | | | | | | | | | |
| | x | x | x | x | x | x | x | | | | | | | | | | | | | | | | | | | | | | | | | | | | | | | | | | | | | | | | | | | | | | | | | | | | | | | | | | | | | | | | | | | | | |
| | x | x | x | x | x | x | x | | | | | | | | | | | | | | | | | | | | | | | | | | | | | | | | | | | | | | | | | | | | | | | | | | | | | | | | | | | | | | | | | | | | | |
| | x | x | x | x | x | x | x | | | | | | | | | | | | | | | | | | | | | | | | | | | | | | | | | | | | | | | | | | | | | | | | | | | | | | | | | | | | | | | | | | | | | |
| | | | | | | | DP | | | | | | | | | | | | | | | | | | | | | | | | | | | | | | | | | | | | | | | | | | | | | | | | | | | | | | | | | | | | | | | | | | | | | |
| MSB | | | | LSB | | | | | | | | | | | | | | | | | | | | | | | | | | | | | | | | | | | | | | | | | | | | | | | | | | | | | | | | | | | | | | | | | | | | | | | | |
| c | b | a | f | g | e | d | DP | | | | | | | | | | | | | | | | | | | | | | | | | | | | | | | | | | | | | | | | | | | | | | | | | | | | | | | | | | | | | | | | | | | | | |
| 1 : 2 multiplex | | | <table border="1"> <tr> <td>n</td> <td>n+1</td> <td>n+2</td> <td>n+3</td> <td colspan="4">---</td> </tr> <tr> <td>bit/BP</td> <td>0</td> <td>1</td> <td>2</td> <td>3</td> <td colspan="3">---</td> </tr> <tr> <td></td> <td>a</td> <td>f</td> <td>e</td> <td>d</td> <td colspan="3">---</td> </tr> <tr> <td></td> <td>b</td> <td>g</td> <td>c</td> <td>DP</td> <td colspan="3">---</td> </tr> <tr> <td></td> <td>x</td> <td>x</td> <td>x</td> <td>x</td> <td colspan="3">---</td> </tr> <tr> <td></td> <td>x</td> <td>x</td> <td>x</td> <td>x</td> <td colspan="3">---</td> </tr> </table> | n | n+1 | n+2 | n+3 | --- | | | | bit/BP | 0 | 1 | 2 | 3 | --- | | | | a | f | e | d | --- | | | | b | g | c | DP | --- | | | | x | x | x | x | --- | | | | x | x | x | x | --- | | | <table border="1"> <tr> <td colspan="4">MSB</td> <td colspan="4">LSB</td> </tr> <tr> <td>a</td> <td>b</td> <td>f</td> <td>g</td> <td>e</td> <td>c</td> <td>d</td> <td>DP</td> </tr> </table> | MSB | | | | LSB | | | | a | b | f | g | e | c | d | DP | | | | | | | | |
| n | n+1 | n+2 | n+3 | --- | | | | | | | | | | | | | | | | | | | | | | | | | | | | | | | | | | | | | | | | | | | | | | | | | | | | | | | | | | | | | | | | | | | | | | | | |
| bit/BP | 0 | 1 | 2 | 3 | --- | | | | | | | | | | | | | | | | | | | | | | | | | | | | | | | | | | | | | | | | | | | | | | | | | | | | | | | | | | | | | | | | | | | | | | | |
| | a | f | e | d | --- | | | | | | | | | | | | | | | | | | | | | | | | | | | | | | | | | | | | | | | | | | | | | | | | | | | | | | | | | | | | | | | | | | | | | | | |
| | b | g | c | DP | --- | | | | | | | | | | | | | | | | | | | | | | | | | | | | | | | | | | | | | | | | | | | | | | | | | | | | | | | | | | | | | | | | | | | | | | | |
| | x | x | x | x | --- | | | | | | | | | | | | | | | | | | | | | | | | | | | | | | | | | | | | | | | | | | | | | | | | | | | | | | | | | | | | | | | | | | | | | | | |
| | x | x | x | x | --- | | | | | | | | | | | | | | | | | | | | | | | | | | | | | | | | | | | | | | | | | | | | | | | | | | | | | | | | | | | | | | | | | | | | | | | |
| MSB | | | | LSB | | | | | | | | | | | | | | | | | | | | | | | | | | | | | | | | | | | | | | | | | | | | | | | | | | | | | | | | | | | | | | | | | | | | | | | | |
| a | b | f | g | e | c | d | DP | | | | | | | | | | | | | | | | | | | | | | | | | | | | | | | | | | | | | | | | | | | | | | | | | | | | | | | | | | | | | | | | | | | | | |
| 1 : 3 multiplex | | | <table border="1"> <tr> <td>n</td> <td>n+1</td> <td>n+2</td> <td colspan="5">---</td> </tr> <tr> <td>bit/BP</td> <td>0</td> <td>1</td> <td>2</td> <td>3</td> <td colspan="3">---</td> </tr> <tr> <td></td> <td>b</td> <td>a</td> <td>f</td> <td>e</td> <td colspan="3">---</td> </tr> <tr> <td></td> <td>DP</td> <td>d</td> <td>e</td> <td>x</td> <td colspan="3">---</td> </tr> <tr> <td></td> <td>2</td> <td>c</td> <td>g</td> <td>x</td> <td colspan="3">---</td> </tr> <tr> <td></td> <td>3</td> <td>x</td> <td>x</td> <td>x</td> <td colspan="3">---</td> </tr> </table> | n | n+1 | n+2 | --- | | | | | bit/BP | 0 | 1 | 2 | 3 | --- | | | | b | a | f | e | --- | | | | DP | d | e | x | --- | | | | 2 | c | g | x | --- | | | | 3 | x | x | x | --- | | | <table border="1"> <tr> <td colspan="4">MSB</td> <td colspan="4">LSB</td> </tr> <tr> <td>b</td> <td>DP</td> <td>c</td> <td>a</td> <td>d</td> <td>g</td> <td>f</td> <td>e</td> </tr> </table> | MSB | | | | LSB | | | | b | DP | c | a | d | g | f | e | | | | | | | | |
| n | n+1 | n+2 | --- | | | | | | | | | | | | | | | | | | | | | | | | | | | | | | | | | | | | | | | | | | | | | | | | | | | | | | | | | | | | | | | | | | | | | | | | | |
| bit/BP | 0 | 1 | 2 | 3 | --- | | | | | | | | | | | | | | | | | | | | | | | | | | | | | | | | | | | | | | | | | | | | | | | | | | | | | | | | | | | | | | | | | | | | | | | |
| | b | a | f | e | --- | | | | | | | | | | | | | | | | | | | | | | | | | | | | | | | | | | | | | | | | | | | | | | | | | | | | | | | | | | | | | | | | | | | | | | | |
| | DP | d | e | x | --- | | | | | | | | | | | | | | | | | | | | | | | | | | | | | | | | | | | | | | | | | | | | | | | | | | | | | | | | | | | | | | | | | | | | | | | |
| | 2 | c | g | x | --- | | | | | | | | | | | | | | | | | | | | | | | | | | | | | | | | | | | | | | | | | | | | | | | | | | | | | | | | | | | | | | | | | | | | | | | |
| | 3 | x | x | x | --- | | | | | | | | | | | | | | | | | | | | | | | | | | | | | | | | | | | | | | | | | | | | | | | | | | | | | | | | | | | | | | | | | | | | | | | |
| MSB | | | | LSB | | | | | | | | | | | | | | | | | | | | | | | | | | | | | | | | | | | | | | | | | | | | | | | | | | | | | | | | | | | | | | | | | | | | | | | | |
| b | DP | c | a | d | g | f | e | | | | | | | | | | | | | | | | | | | | | | | | | | | | | | | | | | | | | | | | | | | | | | | | | | | | | | | | | | | | | | | | | | | | | |
| 1 : 4 multiplex | | | <table border="1"> <tr> <td>n</td> <td>n+1</td> <td colspan="6">---</td> </tr> <tr> <td>bit/BP</td> <td>0</td> <td>1</td> <td>2</td> <td>3</td> <td colspan="3">---</td> </tr> <tr> <td></td> <td>a</td> <td>f</td> <td>e</td> <td>d</td> <td colspan="3">---</td> </tr> <tr> <td></td> <td>c</td> <td>e</td> <td>e</td> <td>x</td> <td colspan="3">---</td> </tr> <tr> <td></td> <td>2</td> <td>b</td> <td>g</td> <td>x</td> <td colspan="3">---</td> </tr> <tr> <td></td> <td>3</td> <td>DP</td> <td>g</td> <td>d</td> <td colspan="3">---</td> </tr> </table> | n | n+1 | --- | | | | | | bit/BP | 0 | 1 | 2 | 3 | --- | | | | a | f | e | d | --- | | | | c | e | e | x | --- | | | | 2 | b | g | x | --- | | | | 3 | DP | g | d | --- | | | <table border="1"> <tr> <td colspan="4">MSB</td> <td colspan="4">LSB</td> </tr> <tr> <td>a</td> <td>c</td> <td>b</td> <td>DP</td> <td>f</td> <td>e</td> <td>g</td> <td>d</td> </tr> </table> | MSB | | | | LSB | | | | a | c | b | DP | f | e | g | d | | | | | | | | |
| n | n+1 | --- | | | | | | | | | | | | | | | | | | | | | | | | | | | | | | | | | | | | | | | | | | | | | | | | | | | | | | | | | | | | | | | | | | | | | | | | | | |
| bit/BP | 0 | 1 | 2 | 3 | --- | | | | | | | | | | | | | | | | | | | | | | | | | | | | | | | | | | | | | | | | | | | | | | | | | | | | | | | | | | | | | | | | | | | | | | | |
| | a | f | e | d | --- | | | | | | | | | | | | | | | | | | | | | | | | | | | | | | | | | | | | | | | | | | | | | | | | | | | | | | | | | | | | | | | | | | | | | | | |
| | c | e | e | x | --- | | | | | | | | | | | | | | | | | | | | | | | | | | | | | | | | | | | | | | | | | | | | | | | | | | | | | | | | | | | | | | | | | | | | | | | |
| | 2 | b | g | x | --- | | | | | | | | | | | | | | | | | | | | | | | | | | | | | | | | | | | | | | | | | | | | | | | | | | | | | | | | | | | | | | | | | | | | | | | |
| | 3 | DP | g | d | --- | | | | | | | | | | | | | | | | | | | | | | | | | | | | | | | | | | | | | | | | | | | | | | | | | | | | | | | | | | | | | | | | | | | | | | | |
| MSB | | | | LSB | | | | | | | | | | | | | | | | | | | | | | | | | | | | | | | | | | | | | | | | | | | | | | | | | | | | | | | | | | | | | | | | | | | | | | | | |
| a | c | b | DP | f | e | g | d | | | | | | | | | | | | | | | | | | | | | | | | | | | | | | | | | | | | | | | | | | | | | | | | | | | | | | | | | | | | | | | | | | | | | |

M/BE534

x = data bit unchanged.

Fig.11 Relationships between LCD layout, drive mode, display RAM filling order and display data transmitted over the I²C-bus.

Universal LCD driver for low multiplex rates

PCF8576C

CHARACTERISTICS OF THE I²C-BUS

The I²C-bus is for bidirectional, two-line communication between different ICs or modules. The two lines are a serial data line (SDA) and a serial clock line (SCL). Both lines must be connected to a positive supply via a pull-up resistor when connected to the output stages of a device. Data transfer may be initiated only when the bus is not busy.

Bit transfer (see Fig.12)

One data bit is transferred during each clock pulse. The data on the SDA line must remain stable during the HIGH period of the clock pulse as changes in the data line at this time will be interpreted as a control signal.

Start and stop conditions (see Fig.13)

Both data and clock lines remain HIGH when the bus is not busy. A HIGH-to-LOW transition of the data line, while the clock is HIGH is defined as the START condition (S). A LOW-to-HIGH transition of the data line while the clock is HIGH is defined as the STOP condition (P).

System configuration (see Fig.14)

A device generating a message is a 'transmitter', a device receiving a message is the 'receiver'. The device that controls the message is the 'master' and the devices which are controlled by the master are the 'slaves'.

Acknowledge (see Fig.15)

The number of data bytes transferred between the START and STOP conditions from transmitter to receiver is unlimited. Each byte of eight bits is followed by an acknowledge bit. The acknowledge bit is a HIGH level signal put on the bus by the transmitter during which time the master generates an extra acknowledge related clock pulse. A slave receiver which is addressed must generate an acknowledge after the reception of each byte. Also a master receiver must generate an acknowledge after the reception of each byte that has been clocked out of the slave transmitter. The device that acknowledges must pull-down the SDA line during the acknowledge clock pulse, so that the SDA line is stable LOW during the HIGH period of the acknowledge related clock pulse (set-up and hold times must be taken into consideration). A master receiver must signal an end of data to the transmitter by not generating an acknowledge on the last byte that has been clocked out of the slave. In this event the transmitter must leave the data line HIGH to enable the master to generate a STOP condition.

PCF8576C I²C-bus controller

The PCF8576C acts as an I²C-bus slave receiver. It does not initiate I²C-bus transfers or transmit data to an I²C-bus master receiver. The only data output from the PCF8576C are the acknowledge signals of the selected devices. Device selection depends on the I²C-bus slave address, on the transferred command data and on the hardware subaddress.

In single device application, the hardware subaddress inputs A0, A1 and A2 are normally tied to V_{SS} which defines the hardware subaddress 0. In multiple device applications A0, A1 and A2 are tied to V_{SS} or V_{DD} in accordance with a binary coding scheme such that no two devices with a common I²C-bus slave address have the same hardware subaddress.

In the power-saving mode it is possible that the PCF8576C is not able to keep up with the highest transmission rates when large amounts of display data are transmitted. If this situation occurs, the PCF8576C forces the SCL line LOW until its internal operations are completed. This is known as the 'clock synchronization feature' of the I²C-bus and serves to slow down fast transmitters. Data loss does not occur.

Input filters

To enhance noise immunity in electrically adverse environments, RC low-pass filters are provided on the SDA and SCL lines.

I²C-bus protocol

Two I²C-bus slave addresses (0111000 and 0111001) are reserved for the PCF8576C. The least significant bit of the slave address that a PCF8576C will respond to is defined by the level tied at its input SA0 (pin 10). Therefore, two types of PCF8576C can be distinguished on the same I²C-bus which allows:

1. Up to 16 PCF8576Cs on the same I²C-bus for very large LCD applications.
2. The use of two types of LCD multiplex on the same I²C-bus.

The I²C-bus protocol is shown in Fig.16. The sequence is initiated with a START condition (S) from the I²C-bus master which is followed by one of the two PCF8576C slave addresses available. All PCF8576Cs with the corresponding SA0 level acknowledge in parallel with the slave address but all PCF8576Cs with the alternative SA0 level ignore the whole I²C-bus transfer.

Universal LCD driver for low multiplex rates

PCF8576C

After acknowledgement, one or more command bytes (m) follow which define the status of the addressed PCF8576Cs.

The last command byte is tagged with a cleared most significant bit, the continuation bit C. The command bytes are also acknowledged by all addressed PCF8576Cs on the bus.

After the last command byte, a series of display data bytes (n) may follow. These display bytes are stored in the display RAM at the address specified by the data pointer and the subaddress counter. Both data pointer and subaddress counter are automatically updated and the data is directed to the intended PCF8576C device. The acknowledgement after each byte is made only by the (A0, A1 and A2) addressed PCF8576C. After the last display byte, the I²C-bus master issues a STOP condition (P).

Command decoder

The command decoder identifies command bytes that arrive on the I²C-bus. All available commands carry a continuation bit C in their most significant bit position (Fig. 17). When this bit is set, it indicates that the next byte of the transfer to arrive will also represent a command. If this bit is reset, it indicates the last command byte of the transfer. Further bytes will be regarded as display data.

The five commands available to the PCF8576C are defined in Table 5.

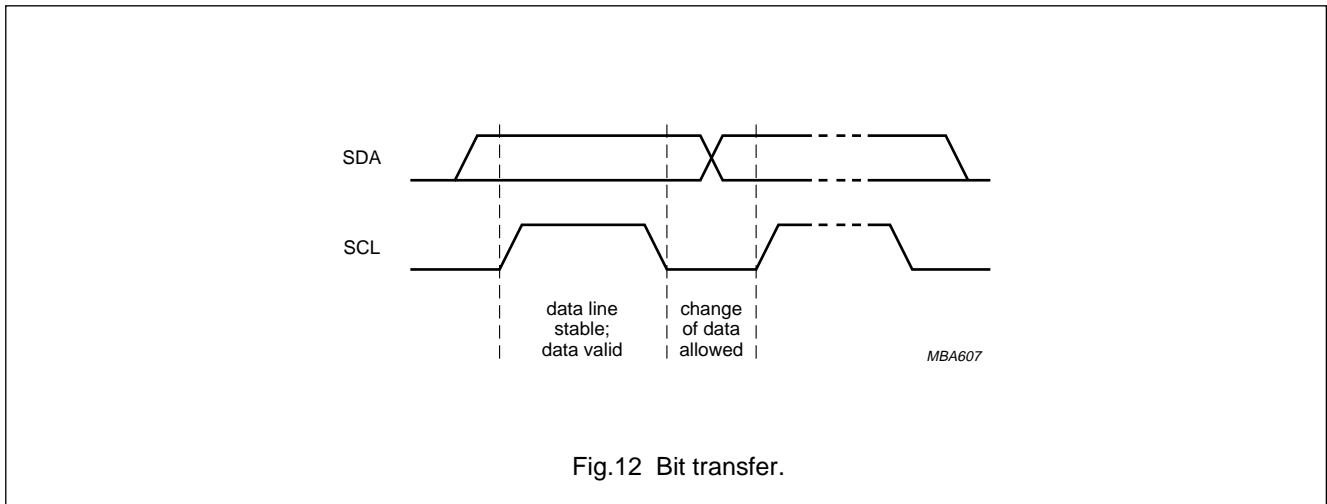

Fig.12 Bit transfer.

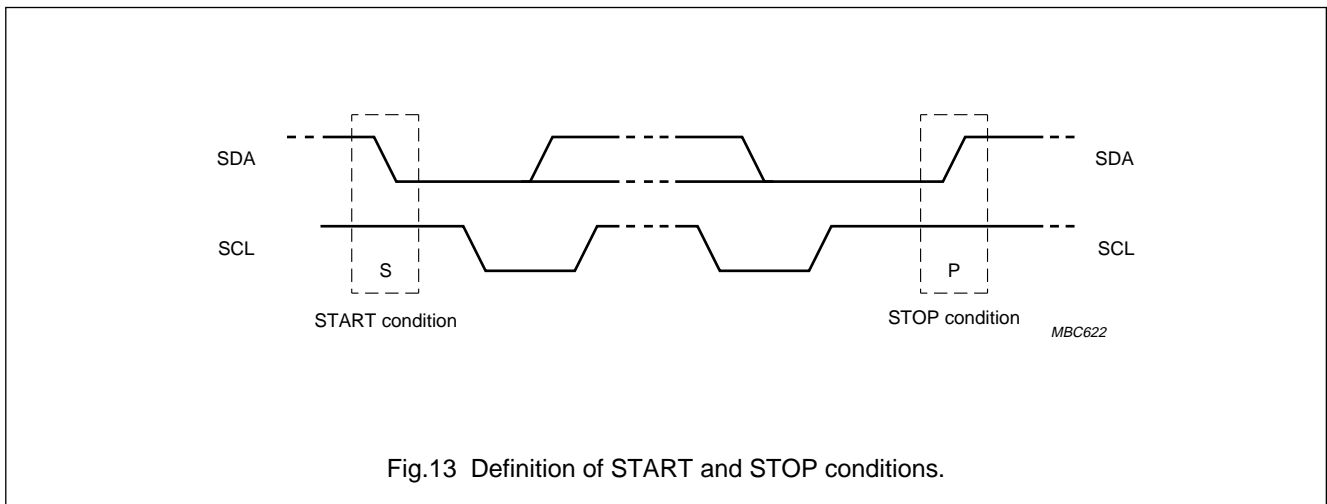

Fig.13 Definition of START and STOP conditions.

Universal LCD driver for low multiplex rates

PCF8576C

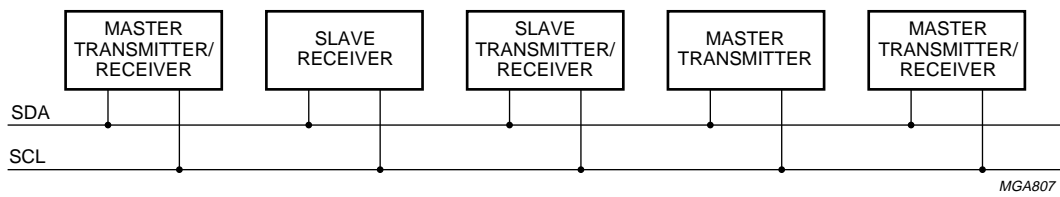

Fig.14 System configuration.

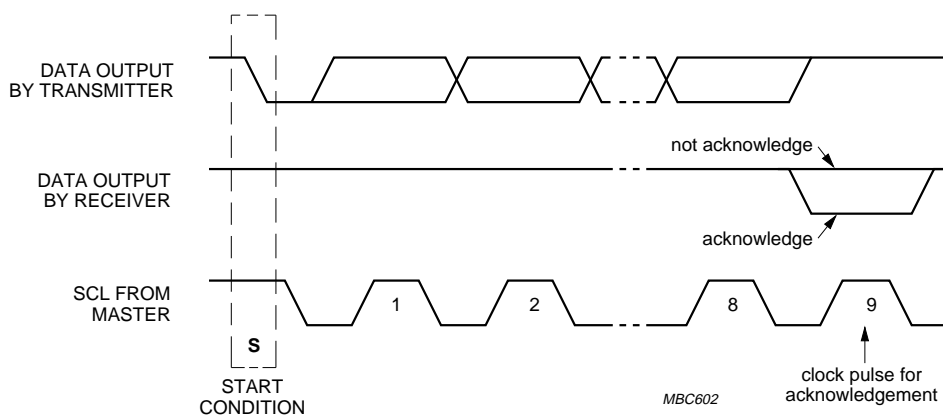

Fig.15 Acknowledgement on the I²C-bus.

Universal LCD driver for low multiplex rates

PCF8576C

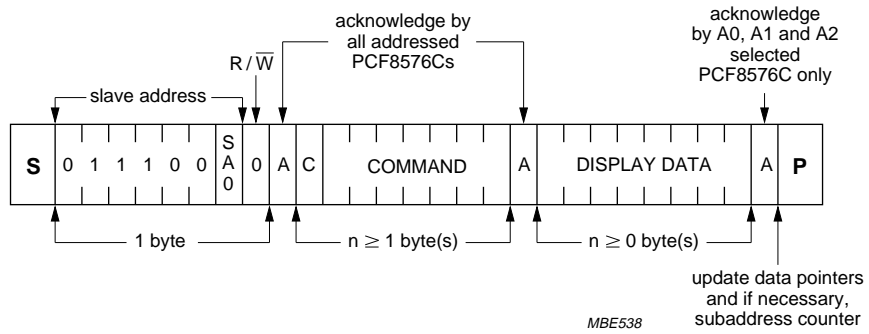
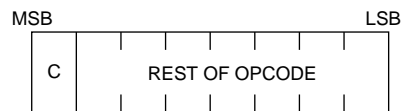

Fig.16 I²C-bus protocol.



MSA833

C = 0; last command.
 C = 1; commands continue.

Fig.17 General format of command byte.

Universal LCD driver for low multiplex rates

PCF8576C

Table 5 Definition of PCF8576C commands

| COMMAND | OPCODE | OPTIONS | DESCRIPTION |
|------------------|-----------------------|----------|---|
| MODE SET | C 1 0 LP E B M1 M0 | Table 6 | Defines LCD drive mode. |
| | | Table 7 | Defines LCD bias configuration. |
| | | Table 8 | Defines display status. The possibility to disable the display allows implementation of blinking under external control. |
| | | Table 9 | Defines power dissipation mode. |
| LOADDATA POINTER | C 0 P5 P4 P3 P2 P1 P0 | Table 10 | Six bits of immediate data, bits P5 to P0, are transferred to the data pointer to define one of forty display RAM addresses. |
| DEVICE SELECT | C 1 1 0 0 A2 A1 A0 | Table 11 | Three bits of immediate data, bits A0 to A3, are transferred to the subaddress counter to define one of eight hardware subaddresses. |
| BANK SELECT | C 1 1 1 1 0 I O | Table 12 | Defines input bank selection (storage of arriving display data). |
| | | Table 13 | Defines output bank selection (retrieval of LCD display data). The BANK SELECT command has no effect in 1 : 3 and 1 : 4 multiplex drive modes. |
| BLINK | C 1 1 1 0 A BF1 BF0 | Table 14 | Defines the blinking frequency. |
| | | Table 15 | Selects the blinking mode; normal operation with frequency set by BF1, BF0 or blinking by alternation of display RAM banks. Alternation blinking does not apply in 1 : 3 and 1 : 4 multiplex drive modes. |

Table 6 Mode set option 1

| LCD DRIVE MODE | | BITS | |
|----------------|------------|------|----|
| DRIVE MODE | BACKPLANE | M1 | M0 |
| Static | 1 BP | 0 | 1 |
| 1 : 2 | MUX (2 BP) | 1 | 0 |
| 1 : 3 | MUX (3 BP) | 1 | 1 |
| 1 : 4 | MUX (4 BP) | 0 | 0 |

Table 7 Mode set option 2

| LCD BIAS | BIT B |
|--------------------|-------|
| $\frac{1}{3}$ bias | 0 |
| $\frac{1}{2}$ bias | 1 |

Table 8 Mode set option 3

| DISPLAY STATUS | BIT E |
|------------------|-------|
| Disabled (blank) | 0 |
| Enabled | 1 |

Table 9 Mode set option 4

| MODE | BIT LP |
|-------------------|--------|
| Normal mode | 0 |
| Power-saving mode | 1 |

Universal LCD driver for low multiplex rates

PCF8576C

Table 10 Load data pointer option 1

| DESCRIPTION | BITS | | | | | |
|-------------------------------|------|----|----|----|----|----|
| 6 bit binary value of 0 to 39 | P5 | P4 | P3 | P2 | P1 | P0 |

Table 11 Device select option 1

| DESCRIPTION | BITS | | |
|------------------------------|------|----|----|
| 3 bit binary value of 0 to 7 | A0 | A1 | A2 |

Table 12 Bank select option 1

| STATIC | 1 : 2 MUX | BIT I |
|-----------|------------------|-------|
| RAM bit 0 | RAM bits 0 and 1 | 0 |
| RAM bit 2 | RAM bits 2 and 3 | 1 |

Table 13 Bank select option 2

| STATIC | 1 : 2 MUX | BIT O |
|-----------|------------------|-------|
| RAM bit 0 | RAM bits 0 and 1 | 0 |
| RAM bit 2 | RAM bits 2 and 3 | 1 |

Display controller

The display controller executes the commands identified by the command decoder. It contains the status registers of the PCF8576C and co-ordinates their effects. The controller is also responsible for loading display data into the display RAM as required by the filling order.

Cascaded operation

In large display configurations, up to 16 PCF8576Cs can be distinguished on the same I²C-bus by using the 3-bit hardware subaddress (A0, A1 and A2) and the programmable I²C-bus slave address (SA0). When cascaded PCF8576Cs are synchronized so that they can share the backplane signals from one of the devices in the cascade. Such an arrangement is cost-effective in large LCD applications since the backplane outputs of only one device need to be through-plated to the backplane electrodes of the display. The other PCF8576Cs of the cascade contribute additional segment outputs but their backplane outputs are left open-circuit (Fig.18).

Table 14 Blink option 1

| BLINK FREQUENCY | BITS | |
|-----------------|------|-----|
| | BF1 | BF0 |
| Off | 0 | 0 |
| 2 Hz | 0 | 1 |
| 1 Hz | 1 | 0 |
| 0.5 Hz | 1 | 1 |

Table 15 Blink option 2

| BLINK MODE | BIT A |
|----------------------|-------|
| Normal blinking | 0 |
| Alternation blinking | 1 |

The $\overline{\text{SYNC}}$ line is provided to maintain the correct synchronization between all cascaded PCF8576Cs. This synchronization is guaranteed after the power-on reset. The only time that $\overline{\text{SYNC}}$ is likely to be needed is if synchronization is accidentally lost (e.g. by noise in adverse electrical environments; or by the definition of a multiplex mode when PCF8576Cs with differing SA0 levels are cascaded). $\overline{\text{SYNC}}$ is organized as an input/output pin; the output selection being realized as an open-drain driver with an internal pull-up resistor. A PCF8576C asserts the $\overline{\text{SYNC}}$ line at the onset of its last active backplane signal and monitors the $\overline{\text{SYNC}}$ line at all other times. Should synchronization in the cascade be lost, it will be restored by the first PCF8576C to assert $\overline{\text{SYNC}}$. The timing relationship between the backplane waveforms and the $\overline{\text{SYNC}}$ signal for the various drive modes of the PCF8576C are shown in Fig.19.

For single plane wiring of packaged PCF8576Cs and chip-on-glass cascading, see Chapter "Application information".

Universal LCD driver for low multiplex rates

PCF8576C

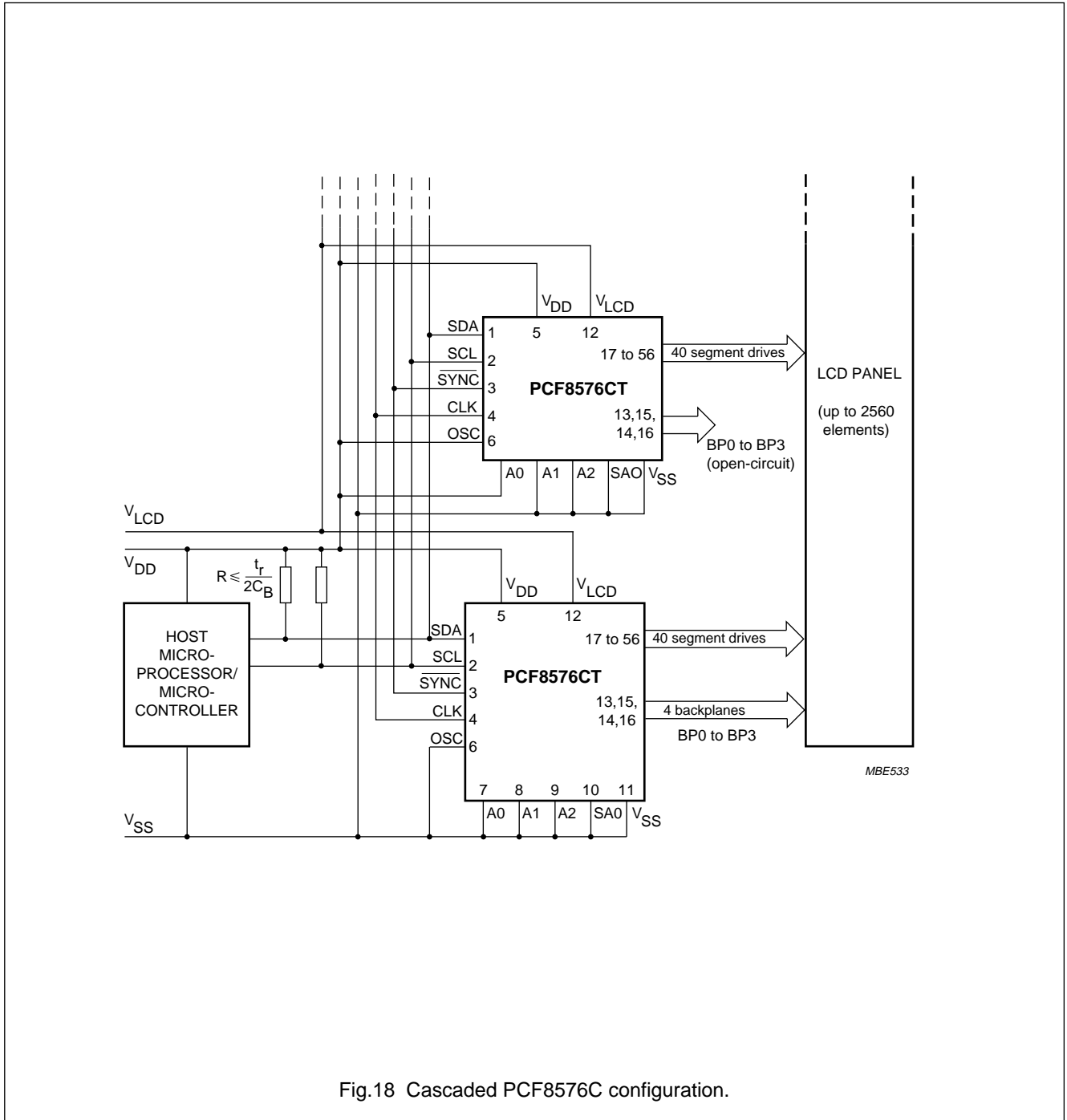
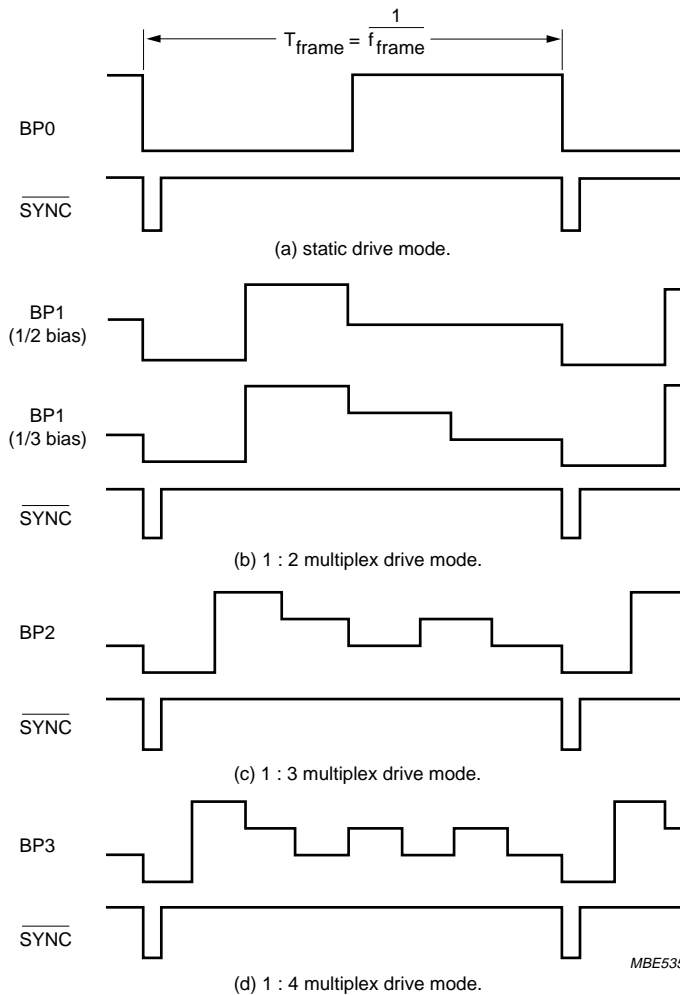

Fig.18 Cascaded PCF8576C configuration.

Universal LCD driver for low multiplex rates

PCF8576C



Excessive capacitive coupling between SCL or CLK and $\overline{\text{SYNC}}$ may cause erroneous synchronization. If this proves to be a problem, the capacitance of the $\overline{\text{SYNC}}$ line should be increased (e.g. by an external capacitor between $\overline{\text{SYNC}}$ and V_{DD}). Degradation of the positive edge of the $\overline{\text{SYNC}}$ pulse may be countered by an external pull-up resistor.

- (a) static drive mode.
- (b) 1 : 2 multiplex drive mode.
- (c) 1 : 3 multiplex drive mode.
- (d) 1 : 4 multiplex drive mode.

Fig.19 Synchronization of the cascade for the various PCF8576C drive modes.

Universal LCD driver for low multiplex rates

PCF8576C

LIMITING VALUES

In accordance with the Absolute Maximum Rating System (IEC 134).

| SYMBOL | PARAMETER | MIN. | MAX. | UNIT |
|---------------------------|---|-----------------|----------------|------|
| V_{DD} | supply voltage | -0.5 | +8.0 | V |
| V_{LCD} | LCD supply voltage | $V_{DD} - 8.0$ | V_{DD} | V |
| V_I | input voltage SDA, SCL, CLK, \overline{SYNC} , SA0, OSC, A0 to A2 | $V_{SS} - 0.5$ | $V_{DD} + 0.5$ | V |
| V_O | output voltage S0 to S39, BP0 to BP3 | $V_{LCD} - 0.5$ | $V_{DD} + 0.5$ | V |
| I_I | DC input current | -20 | +20 | mA |
| I_O | DC output current | -25 | +25 | mA |
| I_{DD}, I_{SS}, I_{LCD} | V_{DD}, V_{SS} or V_{LCD} current | -50 | +50 | mA |
| P_{tot} | total power dissipation | - | 400 | mW |
| P_O | power dissipation per output | - | 100 | mW |
| T_{stg} | storage temperature | -65 | +150 | °C |

HANDLING

Inputs and outputs are protected against electrostatic discharge in normal handling. However, to be totally safe, it is desirable to take normal precautions appropriate to handling MOS devices (see "*Handling MOS Devices*").

Universal LCD driver for low multiplex rates

PCF8576C

DC CHARACTERISTICS

$V_{DD} = 2$ to 6 V; $V_{SS} = 0$ V; $V_{LCD} = V_{DD} - 2$ V to $V_{DD} - 6$ V; $T_{amb} = -40$ to $+85$ °C; unless otherwise specified.

| SYMBOL | PARAMETER | CONDITIONS | MIN. | TYP. | MAX. | UNIT |
|-----------------------|---|---|-----------------|------|--------------|------------|
| Supplies | | | | | | |
| V_{DD} | supply voltage | | 2 | – | 6 | V |
| V_{LCD} | LCD supply voltage | note 1 | $V_{DD} - 6$ | – | $V_{DD} - 2$ | V |
| I_{DD} | supply current | note 2 | | | | |
| | normal mode | $f_{clk} = 200$ kHz | – | – | 120 | μ A |
| | power-saving mode | $f_{clk} = 35$ kHz; $V_{DD} = 3.5$ V; $V_{LCD} = 0$ V; A0, A1 and A2 tied to V_{SS} | – | – | 60 | μ A |
| Logic | | | | | | |
| V_{IL} | LOW level input voltage | | V_{SS} | – | $0.3V_{DD}$ | V |
| V_{IH} | HIGH level input voltage | | $0.7V_{DD}$ | – | V_{DD} | V |
| V_{OL} | LOW level input voltage | $I_{OL} = 0$ mA | – | – | 0.05 | V |
| V_{OH} | HIGH level input voltage | $I_{OH} = 0$ mA | $V_{DD} - 0.05$ | – | – | V |
| I_{OL1} | LOW level output current CLK, \overline{SYNC} | $V_{OL} = 1$ V; $V_{DD} = 5$ V | 1 | – | – | mA |
| I_{OH1} | HIGH level output current CLK | $V_{OH} = 4$ V; $V_{DD} = 5$ V | –1 | – | – | mA |
| I_{OL2} | LOW level output current SDA, SCL | $V_{OL} = 0.4$ V; $V_{DD} = 5$ V | 3 | – | – | mA |
| I_{L1} | leakage current SA0, A0 to A2, CLK, SDA and SCL | $V_I = V_{DD}$ or V_{SS} | –1 | – | +1 | μ A |
| I_{L2} | leakage current OSC | $V_I = V_{DD}$ | –1 | – | +1 | μ A |
| I_{pd} | A0, A1, A2 and OSC pull-down current | $V_I = 1$ V; $V_{DD} = 5$ V | 15 | 50 | 150 | μ A |
| $R_{\overline{SYNC}}$ | pull-up resistor (\overline{SYNC}) | | 20 | 50 | 150 | k Ω |
| V_{POR} | power-on reset voltage level | note 3 | – | 1.0 | 1.6 | V |
| t_{SW} | tolerable spike width on bus | | – | – | 100 | ns |
| C_I | input capacitance | note 4 | – | – | 7 | pF |
| LCD outputs | | | | | | |
| V_{BP} | DC voltage component BP0 to BP3 | $C_{BP} = 35$ nF | –20 | – | +20 | mV |
| V_S | DC voltage component S0 to S39 | $C_S = 5$ nF | –20 | – | +20 | mV |
| R_{BP} | output resistance BP0 to BP3 | note 5; $V_{LCD} = V_{DD} - 5$ V | – | – | 5 | k Ω |
| R_S | output resistance S0 to S39 | note 5; $V_{LCD} = V_{DD} - 5$ V | – | – | 7.5 | k Ω |

Notes

- $V_{LCD} \leq V_{DD} - 3$ V for $\frac{1}{3}$ bias.
- LCD outputs are open-circuit; inputs at V_{SS} or V_{DD} ; external clock with 50% duty factor; I²C-bus inactive.
- Resets all logic when $V_{DD} < V_{POR}$.
- Periodically sampled, not 100% tested.
- Outputs measured one at a time.

Universal LCD driver for low multiplex rates

PCF8576C

AC CHARACTERISTICS

$V_{DD} = 2$ to 6 V; $V_{SS} = 0$ V; $V_{LCD} = V_{DD} - 2$ V to $V_{DD} - 6$ V; $T_{amb} = -40$ to $+85$ °C; unless otherwise specified.

| SYMBOL | PARAMETER | CONDITIONS | MIN. | TYP. | MAX. | UNIT |
|-------------|--|--------------------------|------|------|------|---------|
| f_{clk} | oscillator frequency | | | | | |
| | normal mode | $V_{DD} = 5$ V; note 1 | 125 | 200 | 315 | kHz |
| | power-saving mode | $V_{DD} = 3.5$ V | 21 | 31 | 48 | kHz |
| t_{clkH} | CLK HIGH time | | 1 | – | – | μ s |
| t_{clkL} | CLK LOW time | | 1 | – | – | μ s |
| t_{PSYNC} | \overline{SYNC} propagation delay time | | – | – | 400 | ns |
| t_{SYNCL} | \overline{SYNC} LOW time | | 1 | – | – | μ s |
| t_{PLCD} | driver delays with test loads | $V_{LCD} = V_{DD} - 5$ V | – | – | 30 | μ s |

Timing characteristics: I²C-bus; note 2

| | | | | | | |
|--------------|--|--|-----|---|-----|---------|
| t_{BUF} | bus free time | | 4.7 | – | – | μ s |
| $t_{HD;STA}$ | START condition hold time | | 4.0 | – | – | μ s |
| $t_{SU;STA}$ | set-up time for a repeated START condition | | 4.7 | – | – | μ s |
| t_{LOW} | SCL LOW time | | 4.7 | – | – | μ s |
| t_{HIGH} | SCL HIGH time | | 4.0 | – | – | μ s |
| t_r | SCL and SDA rise time | | – | – | 1 | μ s |
| t_f | SCL and SDA fall time | | – | – | 0.3 | μ s |
| C_B | capacitive bus line load | | – | – | 400 | pF |
| $t_{SU;DAT}$ | data set-up time | | 250 | – | – | ns |
| $t_{HD;DAT}$ | data hold time | | 0 | – | – | ns |
| $t_{SU;STO}$ | set-up time for STOP condition | | 4.0 | – | – | μ s |

Notes

- At $f_{clk} < 125$ kHz, I²C-bus maximum transmission speed is derated.
- All timing values are valid within the operating supply voltage and ambient temperature range and are referenced to V_{IL} and V_{IH} with an input voltage swing of V_{SS} to V_{DD} .

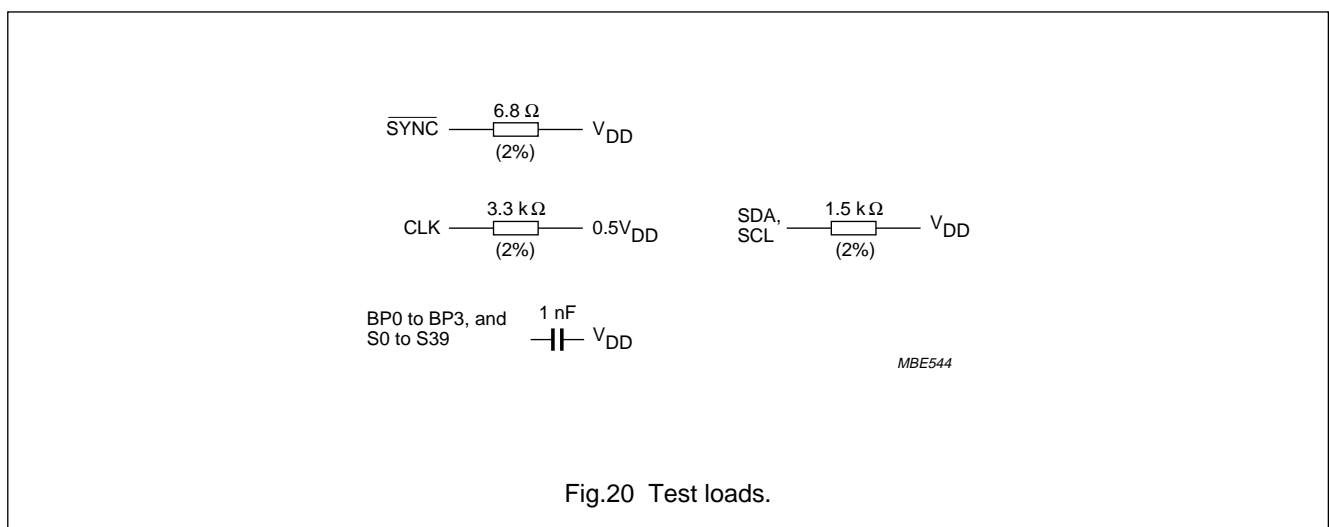

Universal LCD driver for low multiplex rates

PCF8576C

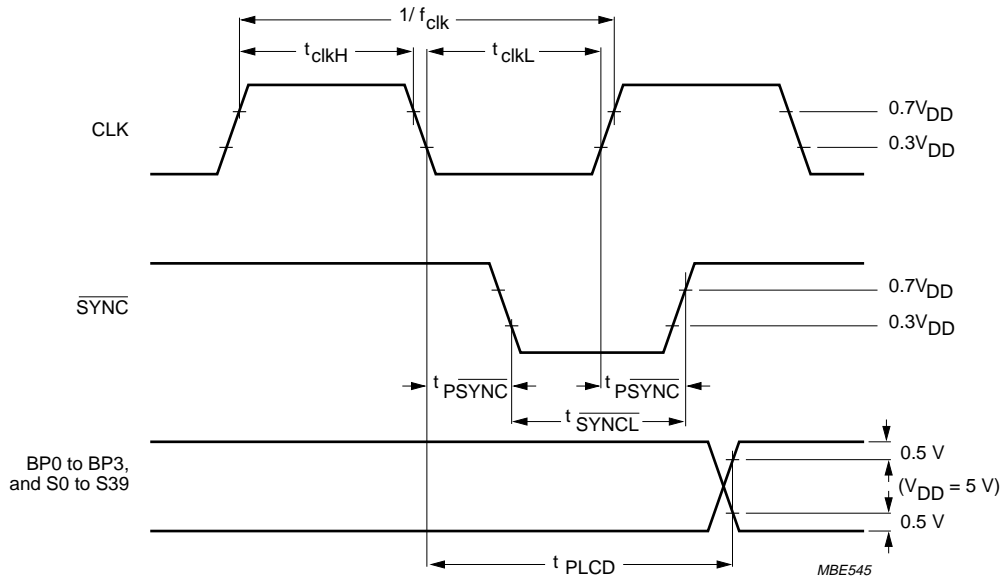

Fig.21 Driver timing waveforms.

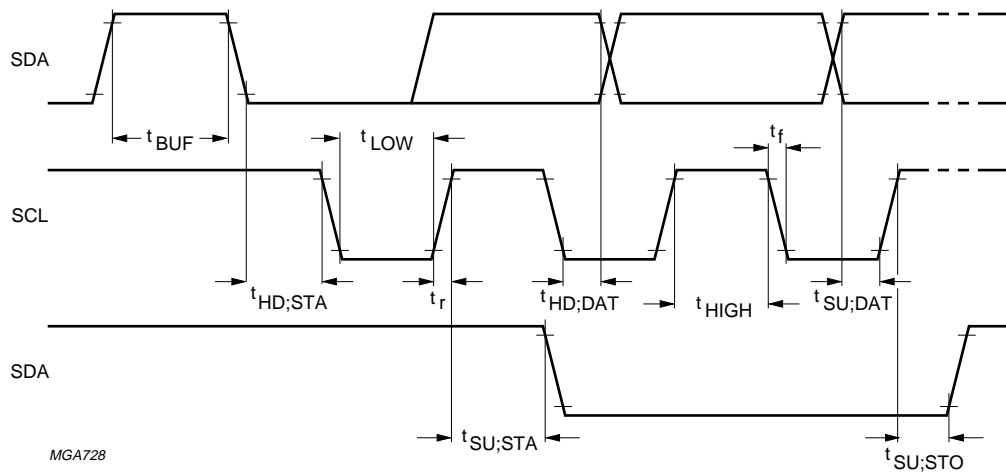
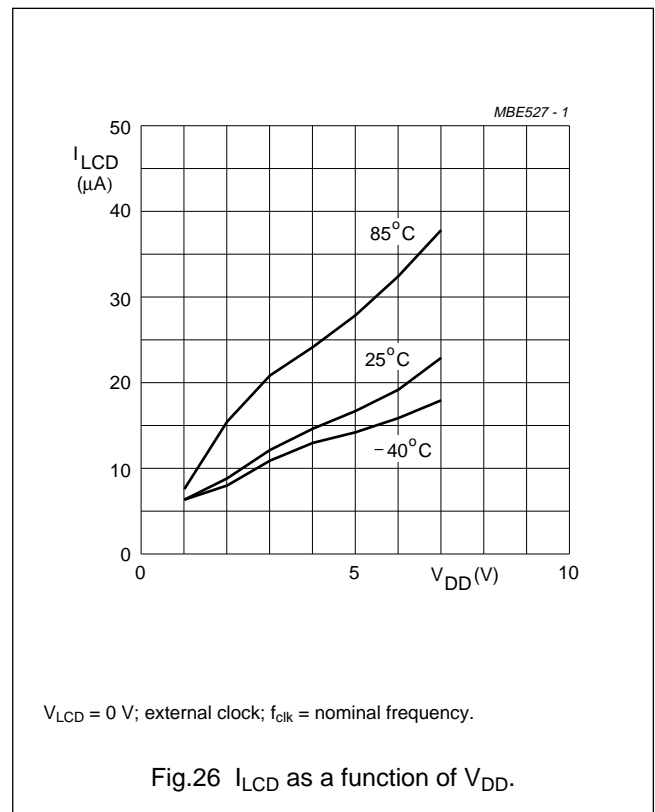
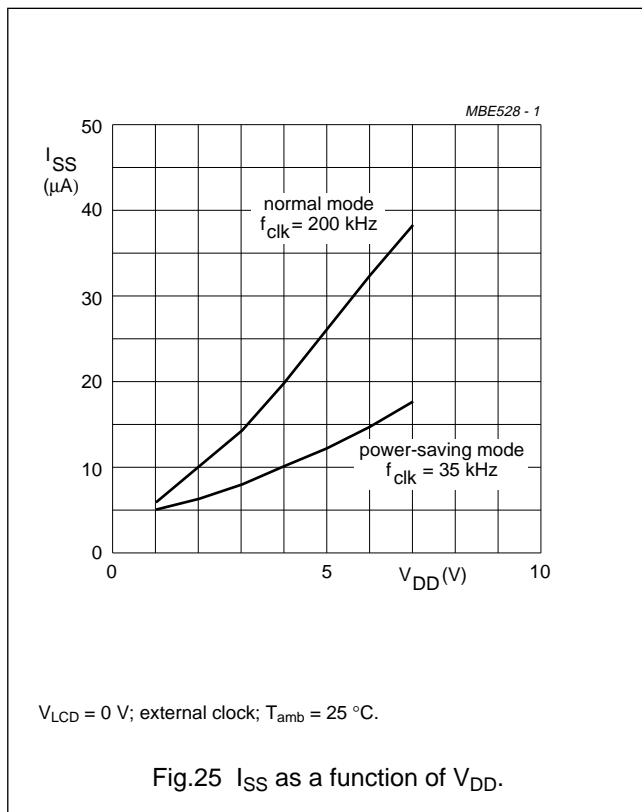
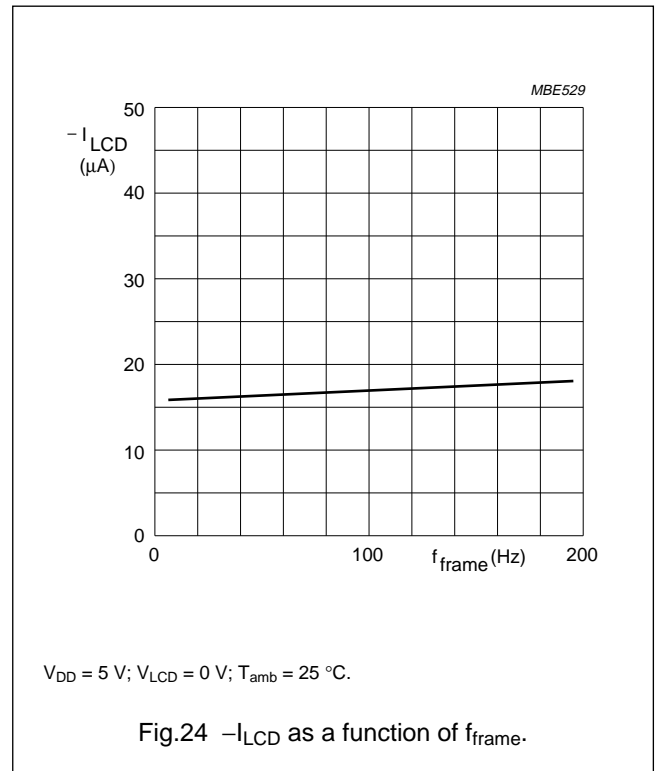
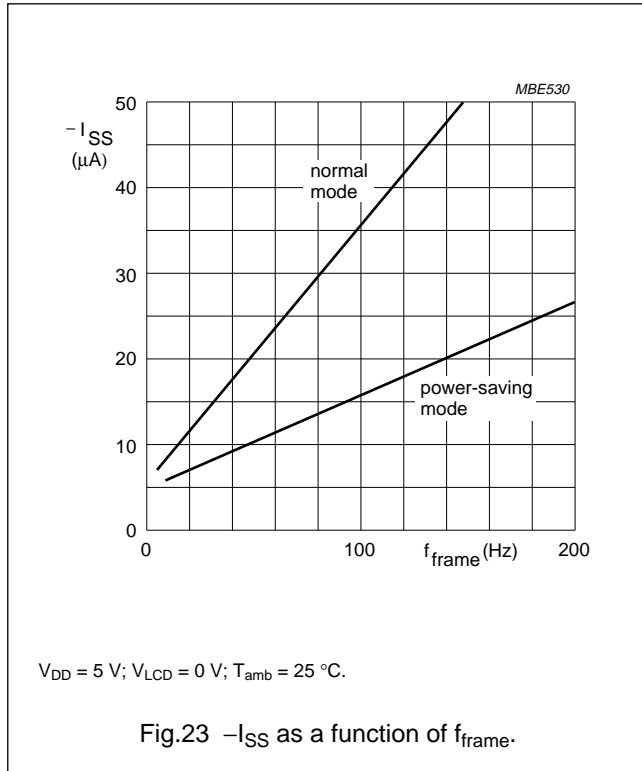

Fig.22 I²C-bus timing waveforms.

Universal LCD driver for low multiplex rates

PCF8576C

Typical supply current characteristics



Universal LCD driver for low multiplex rates

PCF8576C

Typical characteristics of LC D outputs

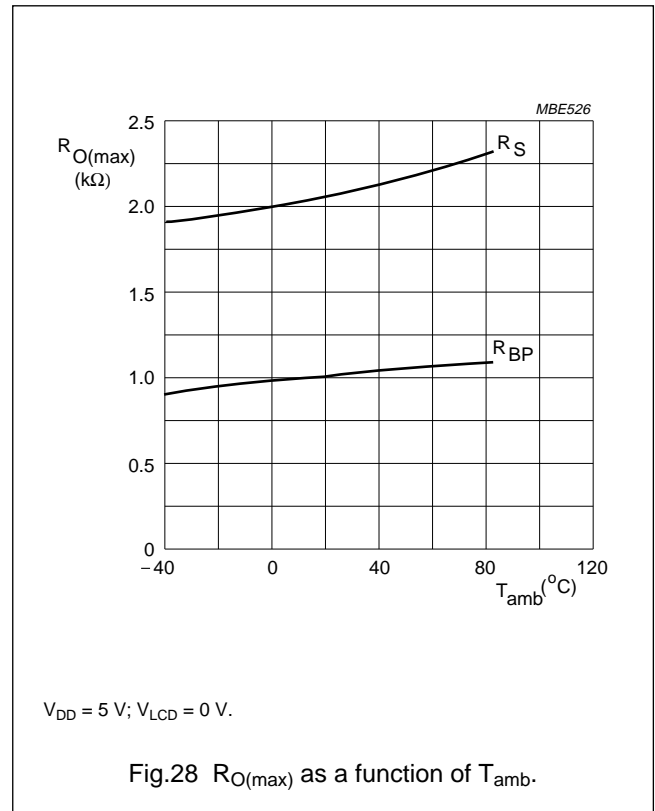
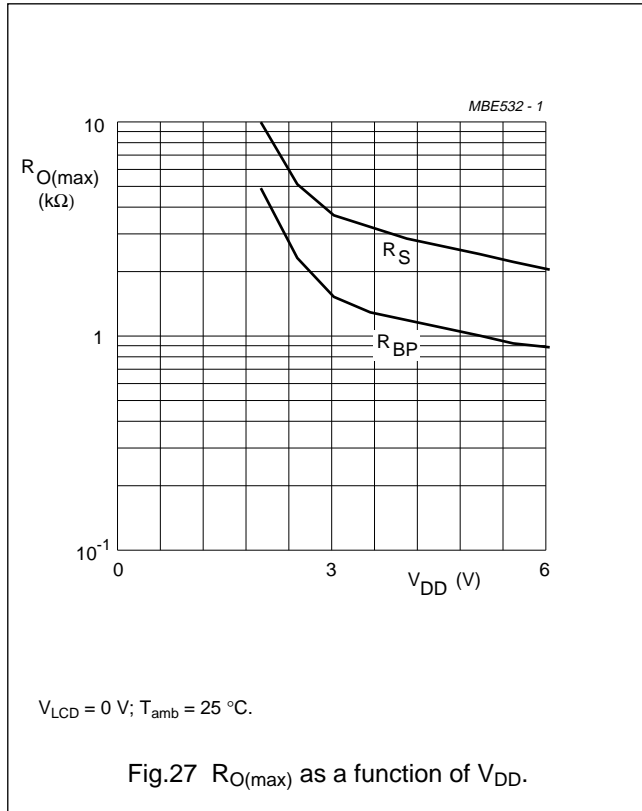

Universal LCD driver for low multiplex rates

PCF8576C

APPLICATION INFORMATION

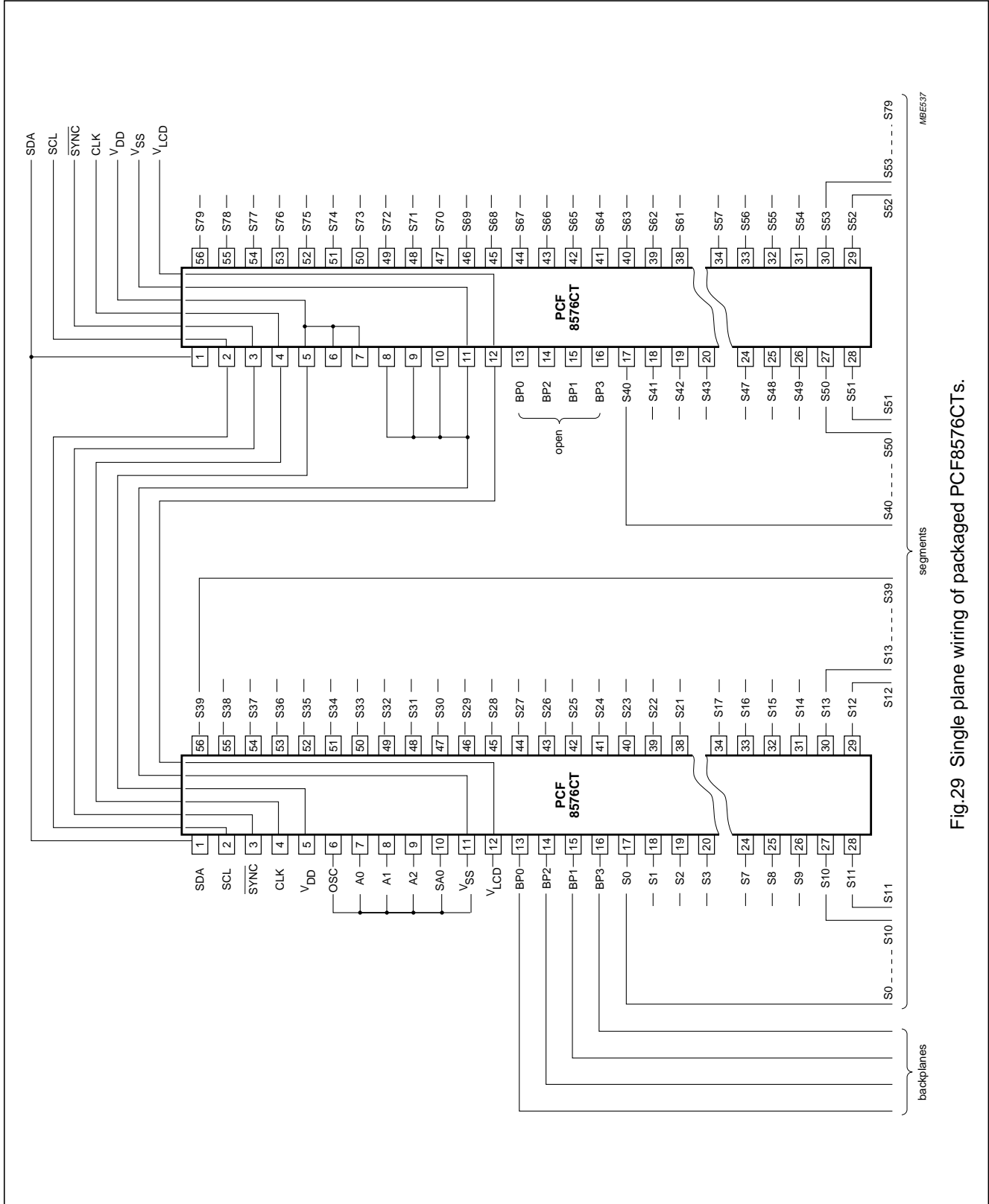

Fig.29 Single plane wiring of packaged PCF8576CTs.

Universal LCD driver for low multiplex rates

PCF8576C

Chip-on-glass cascability in single plane

In chip-on-glass technology, where driver devices are bonded directly onto glass of the LCD, it is important that the devices may be cascaded without the crossing of conductors, but the paths of conductors can be continued on the glass under the chip. All of this is facilitated by the PCF8576C bonding pad layout (Fig.30). Pads needing bus interconnection between all PCF8576Cs of the cascade are V_{DD} , V_{SS} , V_{LCD} , CLK, SCL, SDA and \overline{SYNC} . These lines may be led to the corresponding pads of the next PCF8576C through the wide opening between V_{LCD} pad and the backplane output pads.

The only bussed line that does not require a second opening to lead through to the next PCF8576C is V_{LCD} , being the cascade centre. The placing of V_{LCD} adjacent to V_{SS} allows the two supplies to be tied together.

When an external clocking source is to be used, OSC of all devices should be tied to V_{DD} . The pads OSC, A0, A1, A2 and SA0 have been placed between V_{SS} and V_{DD} to facilitate wiring of oscillator, hardware subaddress and slave address.

BONDING PAD LOCATIONS

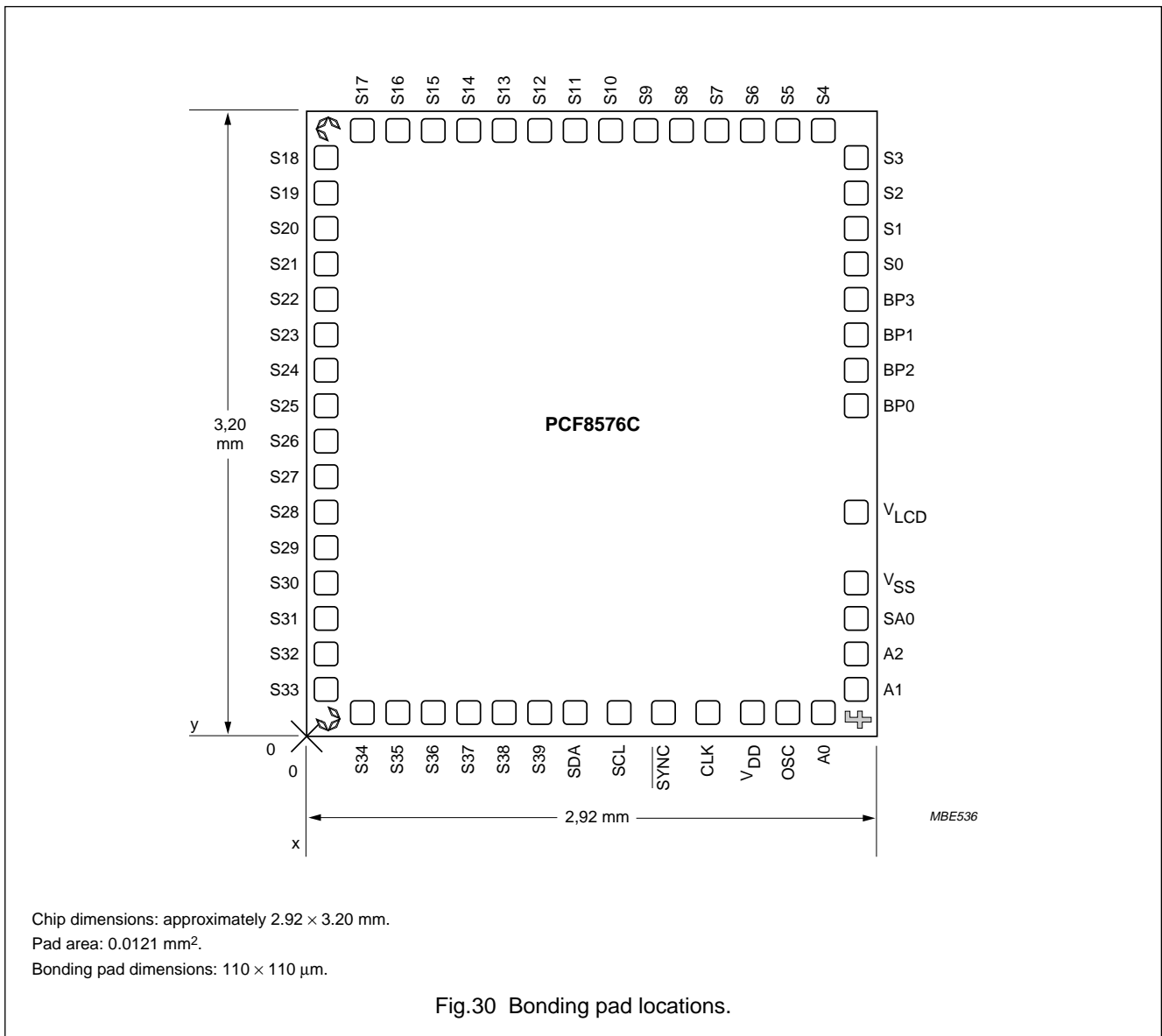

Universal LCD driver for low multiplex rates

PCF8576C

Table 16 Bonding pad locations (dimensions in μm)

All x/y coordinates are referenced to left-hand bottom corner of chip (see Fig.30).

| SYMBOL | PAD | x | y |
|------------------|-----|------|-------|
| SDA | 1 | -74 | -1380 |
| SCL | 2 | 148 | -1380 |
| SYNC | 3 | 355 | -1380 |
| CLK | 4 | 534 | -1380 |
| V _{DD} | 5 | 742 | -1380 |
| OSC | 6 | 913 | -1380 |
| A0 | 7 | 1087 | -1380 |
| A1 | 8 | 1290 | -1284 |
| A2 | 9 | 1290 | -1116 |
| SA0 | 10 | 1290 | -945 |
| V _{SS} | 11 | 1290 | -751 |
| V _{LCD} | 12 | 1290 | -485 |
| BP0 | 13 | 1290 | 125 |
| BP1 | 14 | 1290 | 285 |
| BP2 | 15 | 1290 | 458 |
| BP3 | 16 | 1290 | 618 |
| S0 | 17 | 1290 | 791 |
| S1 | 18 | 1290 | 951 |
| S2 | 19 | 1290 | 1124 |
| S3 | 20 | 1290 | 1284 |
| S4 | 21 | 1074 | 1380 |
| S5 | 22 | 914 | 1380 |
| S6 | 23 | 741 | 1380 |
| S7 | 24 | 581 | 1380 |
| S8 | 25 | 408 | 1380 |
| S9 | 26 | 248 | 1380 |
| S10 | 27 | 75 | 1380 |
| S11 | 28 | -85 | 1380 |
| S12 | 29 | -258 | 1380 |
| S13 | 30 | -418 | 1380 |
| S14 | 31 | -591 | 1380 |

| SYMBOL | PAD | x | y |
|------------------------|-----|-------|-------|
| S15 | 32 | -751 | 1380 |
| S16 | 33 | -924 | 1380 |
| S17 | 34 | -1084 | 1380 |
| S18 | 35 | -1290 | 1243 |
| S19 | 36 | -1290 | 1083 |
| S20 | 37 | -1290 | 910 |
| S21 | 38 | -1290 | 750 |
| S22 | 39 | -1290 | 577 |
| S23 | 40 | -1290 | 417 |
| S24 | 41 | -1290 | 244 |
| S25 | 42 | -1290 | 84 |
| S26 | 43 | -1290 | -89 |
| S27 | 44 | -1290 | -249 |
| S28 | 45 | -1290 | -422 |
| S29 | 46 | -1290 | -582 |
| S30 | 47 | -1290 | -755 |
| S31 | 48 | -1290 | -915 |
| S32 | 49 | -1290 | -1088 |
| S33 | 50 | -1290 | -1248 |
| S34 | 51 | -1083 | -1380 |
| S35 | 52 | -923 | -1380 |
| S36 | 53 | -750 | -1380 |
| S37 | 54 | -590 | -1380 |
| S38 | 55 | -417 | -1380 |
| S39 | 56 | -257 | -1380 |
| Alignment marks | | | |
| C1 | - | -1290 | 1385 |
| C2 | - | -1295 | -1385 |
| F | - | 1305 | -1405 |

Universal LCD driver for low multiplex rates

PCF8576C

PACKAGE OUTLINES

VSO56: plastic very small outline package; 56 leads

SOT190-1

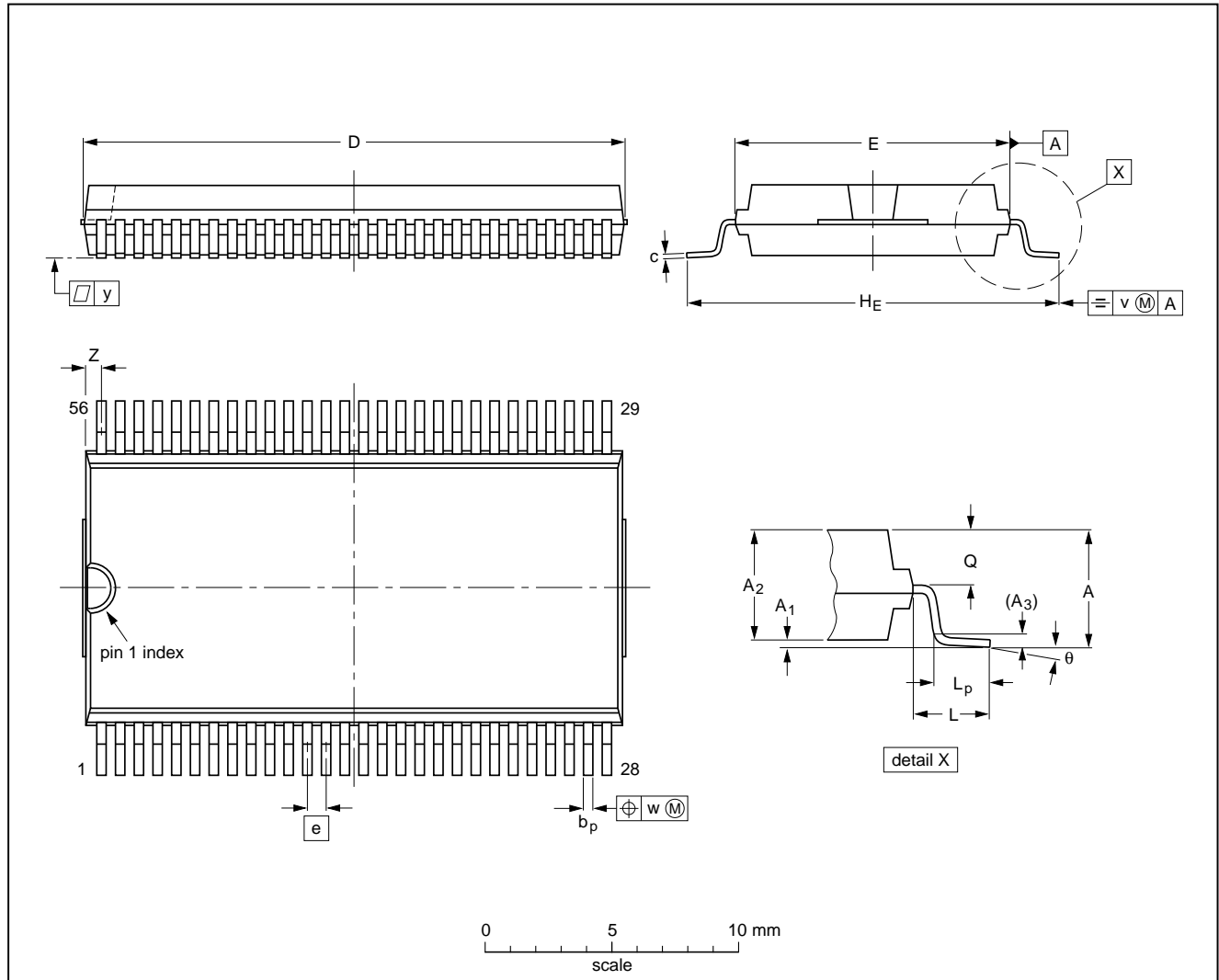

DIMENSIONS (inch dimensions are derived from the original mm dimensions)

| UNIT | A max. | A ₁ | A ₂ | A ₃ | b _p | c | D ⁽¹⁾ | E ⁽²⁾ | e | H _E | L | L _p | Q | v | w | y | Z ⁽¹⁾ | θ |
|--------|--------|----------------|----------------|----------------|----------------|------------------|------------------|------------------|------|----------------|-------|----------------|----------------|-------|-------|-------|------------------|----------|
| mm | 3.3 | 0.3 0.1 | 3.0 2.8 | 0.25 | 0.42 0.30 | 0.22 0.14 | 21.65 21.35 | 11.1 11.0 | 0.75 | 15.8 15.2 | 2.25 | 1.6 1.4 | 1.45 1.30 | 0.2 | 0.1 | 0.1 | 0.90 0.55 | 7° 0° |
| inches | 0.13 | 0.012 0.004 | 0.12 0.11 | 0.01 | 0.017 0.012 | 0.0087 0.0055 | 0.85 0.84 | 0.44 0.43 | 0.03 | 0.62 0.60 | 0.089 | 0.063 0.055 | 0.057 0.051 | 0.008 | 0.004 | 0.004 | 0.035 0.022 | |

Note

1. Plastic or metal protrusions of 0.3 mm maximum per side are not included.
2. Plastic interlead protrusions of 0.25 mm maximum per side are not included.

| OUTLINE VERSION | REFERENCES | | | | EUROPEAN PROJECTION | ISSUE DATE |
|-----------------|------------|-------|------|--|---------------------|----------------------|
| | IEC | JEDEC | EIAJ | | | |
| SOT190-1 | | | | | | 92-11-17 96-04-02 |

Universal LCD driver for low multiplex rates

PCF8576C

LQFP64: plastic low profile quad flat package; 64 leads; body 10 x 10 x 1.4 mm

SOT314-2

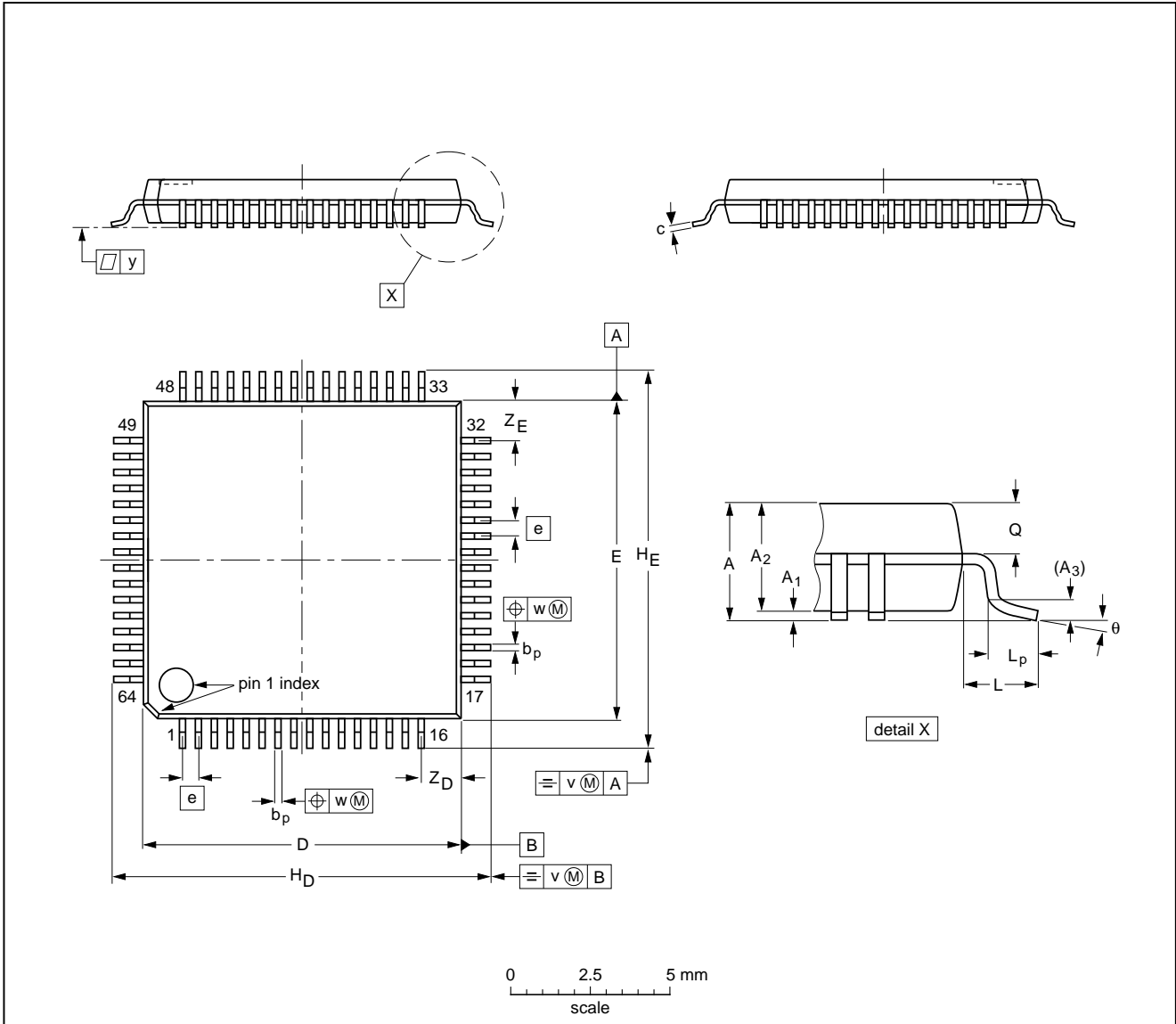

DIMENSIONS (mm are the original dimensions)

| UNIT | A max. | A ₁ | A ₂ | A ₃ | b _p | c | D ⁽¹⁾ | E ⁽¹⁾ | e | H _D | H _E | L | L _p | Q | v | w | y | Z _D ⁽¹⁾ | Z _E ⁽¹⁾ | θ |
|------|--------|----------------|----------------|----------------|----------------|--------------|------------------|------------------|-----|----------------|----------------|-----|----------------|--------------|-----|------|-----|-------------------------------|-------------------------------|----------|
| mm | 1.60 | 0.20 0.05 | 1.45 1.35 | 0.25 | 0.27 0.17 | 0.18 0.12 | 10.1 9.9 | 10.1 9.9 | 0.5 | 12.15 11.85 | 12.15 11.85 | 1.0 | 0.75 0.45 | 0.69 0.59 | 0.2 | 0.12 | 0.1 | 1.45 1.05 | 1.45 1.05 | 7° 0° |

Note

1. Plastic or metal protrusions of 0.25 mm maximum per side are not included.

| OUTLINE VERSION | REFERENCES | | | EUROPEAN PROJECTION | ISSUE DATE |
|-----------------|------------|-------|------|---------------------|----------------------|
| | IEC | JEDEC | EIAJ | | |
| SOT314-2 | | | | | 94-01-07 95-12-19 |

Universal LCD driver for low multiplex rates

PCF8576C

SOLDERING

Introduction

There is no soldering method that is ideal for all IC packages. Wave soldering is often preferred when through-hole and surface mounted components are mixed on one printed-circuit board. However, wave soldering is not always suitable for surface mounted ICs, or for printed-circuits with high population densities. In these situations reflow soldering is often used.

This text gives a very brief insight to a complex technology. A more in-depth account of soldering ICs can be found in our "IC Package Databook" (order code 9398 652 90011).

Reflow soldering

Reflow soldering techniques are suitable for all LQFP and VSO packages.

Reflow soldering requires solder paste (a suspension of fine solder particles, flux and binding agent) to be applied to the printed-circuit board by screen printing, stencilling or pressure-syringe dispensing before package placement.

Several techniques exist for reflowing; for example, thermal conduction by heated belt. Dwell times vary between 50 and 300 seconds depending on heating method. Typical reflow temperatures range from 215 to 250 °C.

Preheating is necessary to dry the paste and evaporate the binding agent. Preheating duration: 45 minutes at 45 °C.

Wave soldering

LQFP

Wave soldering is **not** recommended for LQFP packages. This is because of the likelihood of solder bridging due to closely-spaced leads and the possibility of incomplete solder penetration in multi-lead devices.

If wave soldering cannot be avoided, the following conditions must be observed:

- A double-wave (a turbulent wave with high upward pressure followed by a smooth laminar wave) soldering technique should be used.
- The footprint must be at an angle of 45° to the board direction and must incorporate solder thieves downstream and at the side corners.

Even with these conditions, do not consider wave soldering LQFP packages LQFP48 (SOT313-2), LQFP64 (SOT314-2) or LQFP80 (SOT315-1).

VSO

Wave soldering techniques can be used for all VSO packages if the following conditions are observed:

- A double-wave (a turbulent wave with high upward pressure followed by a smooth laminar wave) soldering technique should be used.
- The longitudinal axis of the package footprint must be parallel to the solder flow.
- The package footprint must incorporate solder thieves at the downstream end.

METHOD (LQFP AND VSO)

During placement and before soldering, the package must be fixed with a droplet of adhesive. The adhesive can be applied by screen printing, pin transfer or syringe dispensing. The package can be soldered after the adhesive is cured.

Maximum permissible solder temperature is 260 °C, and maximum duration of package immersion in solder is 10 seconds, if cooled to less than 150 °C within 6 seconds. Typical dwell time is 4 seconds at 250 °C.

A mildly-activated flux will eliminate the need for removal of corrosive residues in most applications.

Repairing soldered joints

Fix the component by first soldering two diagonally-opposite end leads. Use only a low voltage soldering iron (less than 24 V) applied to the flat part of the lead. Contact time must be limited to 10 seconds at up to 300 °C. When using a dedicated tool, all other leads can be soldered in one operation within 2 to 5 seconds between 270 and 320 °C.

Universal LCD driver for low multiplex rates

PCF8576C

DEFINITIONS

| | |
|---|---|
| Data sheet status | |
| Objective specification | This data sheet contains target or goal specifications for product development. |
| Preliminary specification | This data sheet contains preliminary data; supplementary data may be published later. |
| Product specification | This data sheet contains final product specifications. |
| Limiting values | |
| Limiting values given are in accordance with the Absolute Maximum Rating System (IEC 134). Stress above one or more of the limiting values may cause permanent damage to the device. These are stress ratings only and operation of the device at these or at any other conditions above those given in the Characteristics sections of the specification is not implied. Exposure to limiting values for extended periods may affect device reliability. | |
| Application information | |
| Where application information is given, it is advisory and does not form part of the specification. | |

LIFE SUPPORT APPLICATIONS

These products are not designed for use in life support appliances, devices, or systems where malfunction of these products can reasonably be expected to result in personal injury. Philips customers using or selling these products for use in such applications do so at their own risk and agree to fully indemnify Philips for any damages resulting from such improper use or sale.

PURCHASE OF PHILIPS I²C COMPONENTS



Purchase of Philips I²C components conveys a license under the Philips' I²C patent to use the components in the I²C system provided the system conforms to the I²C specification defined by Philips. This specification can be ordered using the code 9398 393 40011.