



# Dual Low Offset, Low Power Operational Amplifier

## OP200

### FEATURES

- Low Input Offset Voltage ..... **75 $\mu$ V Max**
- Low Offset Voltage Drift,  
Over  $-55^{\circ}\text{C} \leq T_A \leq +125^{\circ}\text{C}$  ..... **0.5 $\mu$ V/ $^{\circ}\text{C}$  Max**
- Low Supply Current (Per Amplifier) ..... **725 $\mu$ A Max**
- High Open-Loop Gain ..... **5000V/mV Min**
- Low Input Bias Current ..... **2nA Max**
- Low Noise Voltage Density ..... **11nV/ $\sqrt{\text{Hz}}$  at 1kHz**
- Stable With Large Capacitive Loads ..... **10nF Typ**
- Pin Compatible to OP-14, OP-221, LM158, MC1458/1558,  
and LT1013 With Improved Performance
- Available in Die Form

### GENERAL DESCRIPTION

The OP-200 is the first monolithic dual operational amplifier to offer OP-77 type precision performance. Available in the industry standard 8-pin pinout, the OP-200 combines precision performance with the space and cost savings offered by a dual amplifier.

The OP-200 features an extremely low input offset voltage of less than 75 $\mu$ V with a drift below 0.5 $\mu$ V/ $^{\circ}\text{C}$ , guaranteed over the

### PIN CONNECTIONS

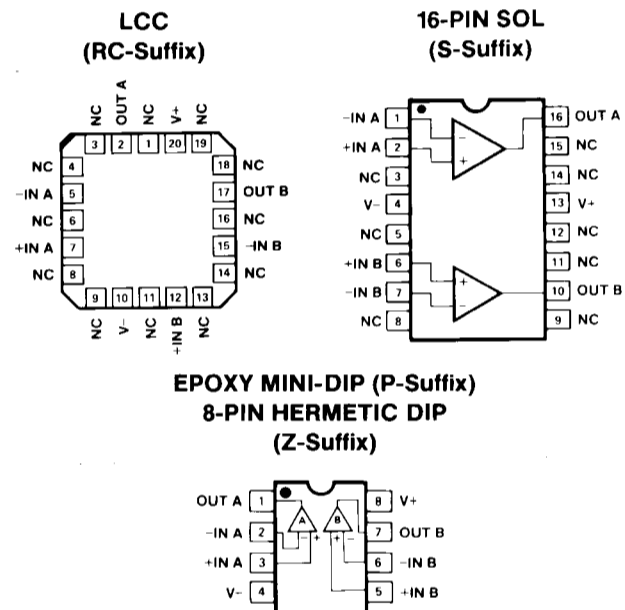

### ORDERING INFORMATION<sup>†</sup>

$T_A = +25^{\circ}\text{C}$ $V_{OS\text{ MAX}}$ ( $\mu\text{V}$ )	PACKAGE			OPERATING TEMPERATURE RANGE
	CERDIP 8-PIN	PLASTIC	LCC 20-CONTACT	
75	OP200AZ*	-	OP200ARC*	MIL
75	OP200EZ	-	-	XIND
150	OP200FZ	-	-	XIND
200	-	OP200GP	-	XIND
200	-	OP200GS <sup>††</sup>	-	XIND

\* For devices processed in total compliance to MIL-STD-883, add /883 after part number. Consult factory for 883 data sheet.

<sup>†</sup> Burn-in is available on commercial and industrial temperature range parts in CerDIP, plastic DIP, and TO-can packages.

<sup>††</sup> For availability and burn-in information on SO and PLCC packages, contact your local sales office.

### SIMPLIFIED SCHEMATIC (One of two amplifiers is shown.)

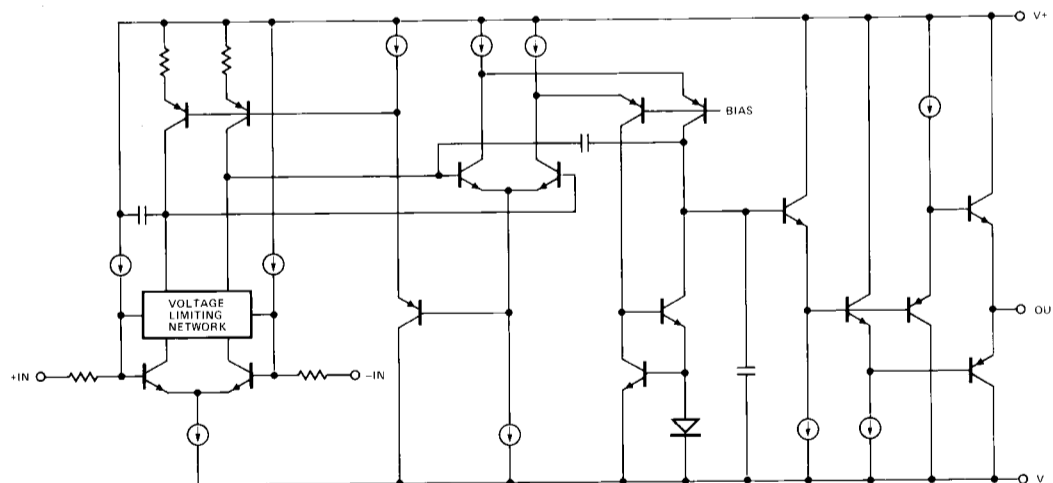

## OP200

full military temperature range. Open-loop gain of the OP-200 exceeds 5,000,000 into a 10k $\Omega$  load; input bias current is under 2nA; CMR is over 120dB and PSRR below 1.8 $\mu$ V/V. On-chip zener-zap trimming is used to achieve the extremely low input offset voltage of the OP-200 and eliminates the need for offset nulling.

Power consumption of the OP-200 is very low, with each amplifier drawing less than 725 $\mu$ A of supply current. The total current drawn by the dual OP-200 is less than one-half that of a single OP-07, yet the OP-200 offers significant improvements over this industry standard op amp. The voltage noise density of the OP-200, 11nV/ $\sqrt{\text{Hz}}$  at 1kHz, is half that of most competitive devices.

The OP-200 is pin compatible with the OP-14, OP-221, LM158, MC1458/1558, and LT1013 and can be used to upgrade systems using these devices. The OP-200 is an ideal choice for applications requiring multiple precision op amps and where low power consumption is critical.

For a quad precision op amp, see the OP-400.

### ABSOLUTE MAXIMUM RATINGS (Note 1)

Supply Voltage .....	$\pm 20\text{V}$
Differential Input Voltage .....	$\pm 30\text{V}$
Input Voltage .....	Supply Voltage
Output Short-Circuit Duration .....	Continuous
Storage Temperature Range	
P, RC, S, Z-Package .....	$-65^{\circ}\text{C}$ to $+150^{\circ}\text{C}$
Lead Temperature Range (Soldering, 60 sec) .....	$300^{\circ}\text{C}$
Junction Temperature ( $T_j$ ) .....	$-65^{\circ}\text{C}$ to $+150^{\circ}\text{C}$
Operating Temperature Range	
OP-200A .....	$-55^{\circ}\text{C}$ to $+125^{\circ}\text{C}$
OP-200E, OP-200F .....	$-40^{\circ}\text{C}$ to $+85^{\circ}\text{C}$
OP-200G .....	$-40^{\circ}\text{C}$ to $+85^{\circ}\text{C}$

PACKAGE TYPE	$\theta_{JA}$ (Note 2)	$\theta_{JC}$	UNITS
8-Pin Hermetic DIP (Z)	148	16	$^{\circ}\text{C}/\text{W}$
8-Pin Plastic DIP (P)	96	37	$^{\circ}\text{C}/\text{W}$
20-Contact LCC (RC)	88	33	$^{\circ}\text{C}/\text{W}$
16-Pin SOL (S)	92	27	$^{\circ}\text{C}/\text{W}$

#### NOTES:

1. Absolute maximum ratings apply to both DICE and packaged parts, unless otherwise noted.
2.  $\theta_{JA}$  is specified for worst case mounting conditions, i.e.,  $\theta_{JA}$  is specified for device in socket for CerDIP, P-DIP, and LCC packages;  $\theta_{JA}$  is specified for device soldered to printed circuit board for SOL package.

### ELECTRICAL CHARACTERISTICS at $V_S = \pm 15\text{V}$ , $T_A = +25^{\circ}\text{C}$ , unless otherwise noted.

PARAMETER	SYMBOL	CONDITIONS	OP-200A/E			OP-200F			OP-200G			UNITS
			MIN	TYP	MAX	MIN	TYP	MAX	MIN	TYP	MAX	
Input Offset Voltage	$V_{OS}$		—	25	75	—	50	150	—	80	200	$\mu\text{V}$
Long Term Input Voltage Stability			—	0.1	—	—	0.1	—	—	0.1	—	$\mu\text{V}/\text{mo}$
Input Offset Current	$I_{OS}$	$V_{CM} = 0\text{V}$	—	0.05	1.0	—	0.05	2.0	—	0.05	3.5	nA
Input Bias Current	$I_B$	$V_{CM} = 0\text{V}$	—	0.1	2.0	—	0.1	4.0	—	0.1	5.0	nA
Input Noise Voltage	$e_{n\text{ p-p}}$	0.1Hz to 10Hz	—	0.5	—	—	0.5	—	—	0.5	—	$\mu\text{V}_{\text{p-p}}$
Input Noise Voltage Density	$e_n$	$f_O = 10\text{Hz}$ $f_O = 1000\text{Hz}$ (Note 1)	—	22	36	—	22	36	—	22	—	$\text{nV}/\sqrt{\text{Hz}}$
Input Noise Current	$i_{n\text{ p-p}}$	0.1Hz to 10Hz	—	15	—	—	15	—	—	15	—	$\text{pA}_{\text{p-p}}$
Input Noise Current Density	$i_n$	$f_O = 10\text{Hz}$	—	0.4	—	—	0.4	—	—	0.4	—	$\text{pA}/\sqrt{\text{Hz}}$
Input Resistance Differential Mode	$R_{IN}$		—	10	—	—	10	—	—	10	—	M $\Omega$
Input Resistance Common Mode	$R_{INCM}$		—	125	—	—	125	—	—	125	—	G $\Omega$
Large Signal Voltage Gain	$A_{VO}$	$V_O = \pm 10\text{V}$ $R_L = 10\text{k}\Omega$ $R_L = 2\text{k}\Omega$	5000	12000	—	3000	7000	—	3000	7000	—	V/mV
			2000	3700	—	1500	3200	—	1500	3200	—	

# OP-200

## ELECTRICAL CHARACTERISTICS at $V_S = \pm 15V$ , $T_A = +25^\circ C$ , unless otherwise noted. (Continued)

PARAMETER	SYMBOL	CONDITIONS	OP-200A/E			OP-200F			OP-200G			UNITS
			MIN	TYP	MAX	MIN	TYP	MAX	MIN	TYP	MAX	
Input Voltage Range	IVR	(Note 3)	$\pm 12$	$\pm 13$	—	$\pm 12$	$\pm 13$	—	$\pm 12$	$\pm 13$	—	V
Common-Mode Rejection	CMR	$V_{CM} = \pm 12V$	120	135	—	115	135	—	110	130	—	dB
Power Supply Rejection Ratio	PSRR	$V_S = \pm 3V$ to $\pm 18V$	—	0.4	1.8	—	0.4	3.2	—	0.6	5.6	$\mu V/V$
Output Voltage Swing	$V_O$	$R_L = 10k\Omega$ $R_L = 2k\Omega$	$\pm 12$ $\pm 11$	$\pm 12.6$ $\pm 12.2$	—	$\pm 12$ $\pm 11$	$\pm 12.6$ $\pm 12.2$	—	$\pm 12$ $\pm 11$	$\pm 12.6$ $\pm 12.2$	—	V
Supply Current Per Amplifier	$I_{SY}$	No Load	—	570	725	—	570	725	—	570	725	$\mu A$
Slew Rate	SR		0.1	0.15	—	0.1	0.15	—	0.1	0.15	—	$V/\mu s$
Gain Bandwidth Product	GBWP	$A_V = +1$	—	500	—	—	500	—	—	500	—	kHz
Channel Separation	CS	$V_O = 20V_{p-p}$ $f_O = 10Hz$ (Note 2)	123	145	—	123	145	—	123	145	—	dB
Input Capacitance	$C_{IN}$		—	3.2	—	—	3.2	—	—	3.2	—	pF
Capacitive Load Stability		$A_V = +1$ No Oscillations	—	10	—	—	10	—	—	10	—	nF

**NOTES:**

1. Sample tested.
2. Guaranteed but not 100% tested.
3. Guaranteed by CMR test.

## ELECTRICAL CHARACTERISTICS at $V_S = +15V$ , $-55^\circ C \leq T_A \leq 125^\circ C$ for OP-200A, unless otherwise noted.

PARAMETER	SYMBOL	CONDITIONS	OP-200A			UNITS
			MIN	TYP	MAX	
Input Offset Voltage	$V_{OS}$		—	45	125	$\mu V$
Average Input Offset Voltage Drift	$TCV_{OS}$		—	0.2	0.5	$\mu V/^\circ C$
Input Offset Current	$I_{OS}$	$V_{CM} = 0V$	—	0.15	2.5	nA
Input Bias Current	$I_B$	$V_{CM} = 0V$	—	0.9	5.0	nA
Large Signal Voltage Gain	$A_{VO}$	$V_O = \pm 10V$ $R_L = 10\Omega$ $R_L = 2k\Omega$	3000 1000	9000 2700	—	$V/mV$
Input Voltage Range	IVR	(Note 1)	$\pm 12$	$\pm 12.5$	—	V
Common-Mode Rejection	CMR	$V_{CM} = \pm 12V$	115	130	—	dB
Power Supply Rejection Ratio	PSRR	$V_S = \pm 3V$ to $\pm 18V$	—	0.2	3.2	$\mu V/V$
Output Voltage Swing	$V_O$	$R_L = 10k\Omega$ $R_L = 2k\Omega$	$\pm 12$ $\pm 11$	$\pm 12.4$ $\pm 12$	—	V
Supply Current Per Amplifier	$I_{SY}$	No Load	—	600	775	$\mu A$
Capacitive Load Stability		$A_V = +1$ No Oscillations	—	8	—	nF

**NOTES:**

1. Guaranteed by CMR test.

# OP200

**ELECTRICAL CHARACTERISTICS** at  $V_S = \pm 15V$ ,  $-40^\circ C \leq T_A \leq +85^\circ C$ , unless otherwise noted.

PARAMETER	SYMBOL	CONDITIONS	OP-200E			OP-200F			OP-200G			UNITS
			MIN	TYP	MAX	MIN	TYP	MAX	MIN	TYP	MAX	
Input Offset Voltage	$V_{OS}$		—	35	100	—	80	250	—	110	300	$\mu V$
Average Input Offset Voltage Drift	$TCV_{OS}$		—	0.2	0.5	—	0.5	1.5	—	0.6	2.0	$\mu V/^\circ C$
Input Offset Current	$I_{OS}$	$V_{CM} = 0V$	—	0.08	2.5	—	0.08	3.5	—	0.1	6.0	nA
Input Bias Current	$I_B$	$V_{CM} = 0V$	—	0.3	5.0	—	0.3	7.0	—	0.5	10.0	nA
Large-Signal Voltage Gain	$A_{VO}$	$V_O = \pm 10V$	3000	10000	—	2000	5000	—	2000	5000	—	V/mV
		$R_L = 10k\Omega$ $R_L = 2k\Omega$	1500	3200	—	1000	2500	—	1000	2500	—	
Input Voltage Range	IVR	(Note 1)	$\pm 12$	$\pm 12.5$	—	$\pm 12$	$\pm 12.5$	—	$\pm 12$	$\pm 12.5$	—	V
Common-Mode Rejection	CMR	$V_{CM} = \pm 12V$	115	130	—	110	130	—	105	130	—	dB
Power Supply Rejection Ratio	PSRR	$V_S = \pm 3V$ to $\pm 18V$	—	0.15	3.2	—	0.15	5.6	—	0.3	10.0	$\mu V/V$
Output Voltage Swing	$V_O$	$R_L = 10k\Omega$	$\pm 12$	$\pm 12.4$	—	$\pm 12$	$\pm 12.4$	—	$\pm 12$	$\pm 12.4$	—	V
		$R_L = 2k\Omega$	$\pm 11$	$\pm 12$	—	$\pm 11$	$\pm 12$	—	$\pm 11$	$\pm 12.2$	—	
Supply Current Per Amplifier	$I_{SY}$	No Load	—	600	775	—	600	775	—	600	775	$\mu A$
Capacitive Load Stability		$A_V = +1$ No Oscillations	—	10	—	—	10	—	—	10	—	nF

**NOTES:**

1. Guaranteed by CMR test.

**CHANNEL SEPARATION TEST CIRCUIT**

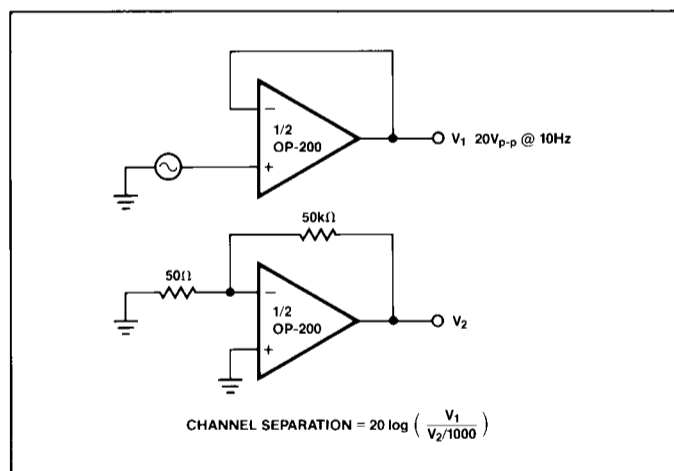

**NOISE TEST SCHEMATIC**

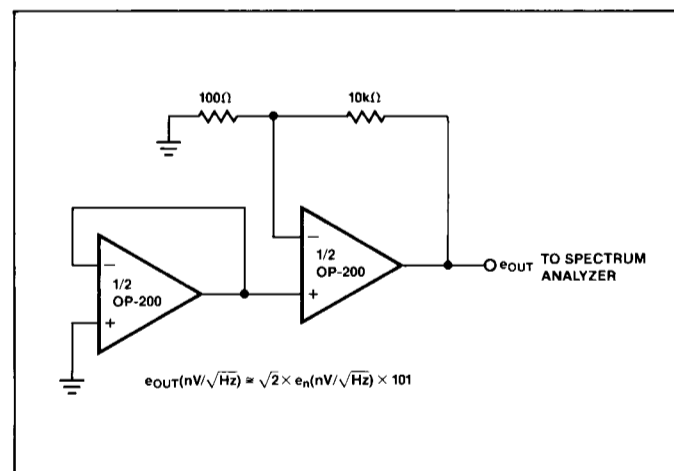

TYPICAL PERFORMANCE CHARACTERISTICS

WARM-UP DRIFT

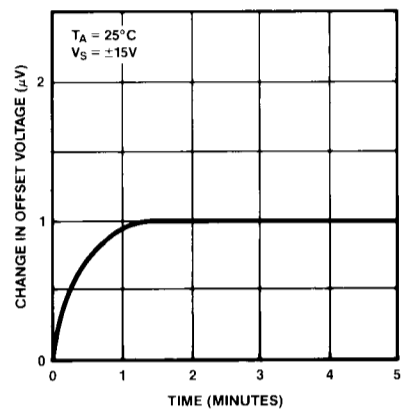

INPUT OFFSET VOLTAGE vs TEMPERATURE

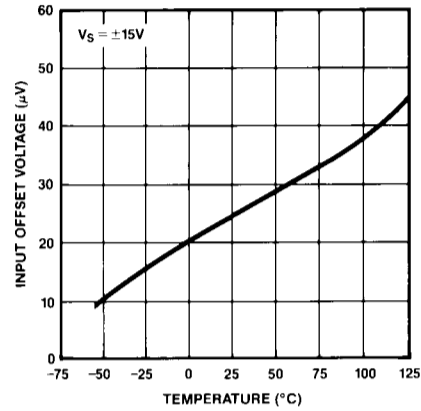

INPUT BIAS CURRENT vs TEMPERATURE

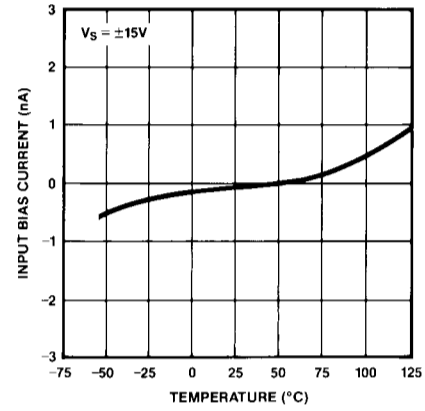

INPUT OFFSET CURRENT vs TEMPERATURE

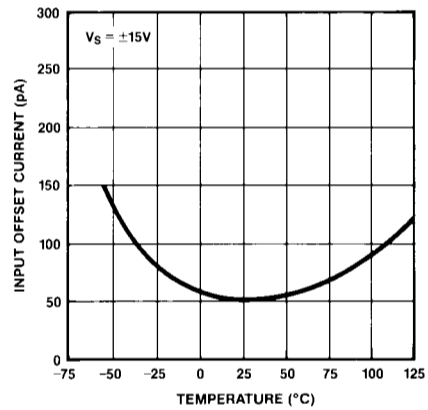

INPUT BIAS CURRENT vs COMMON-MODE VOLTAGE

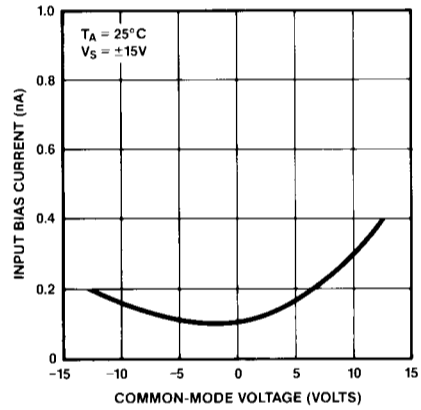

COMMON-MODE REJECTION vs FREQUENCY

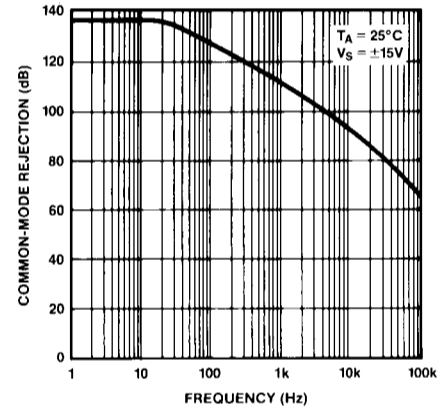

VOLTAGE NOISE DENSITY vs FREQUENCY

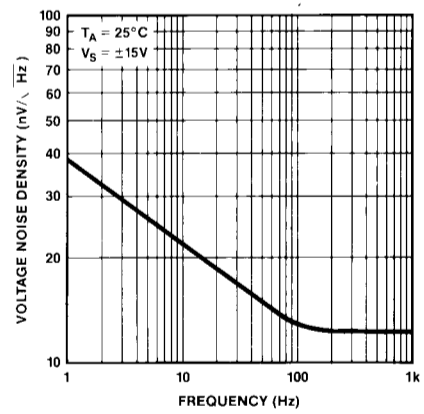

CURRENT NOISE DENSITY vs FREQUENCY

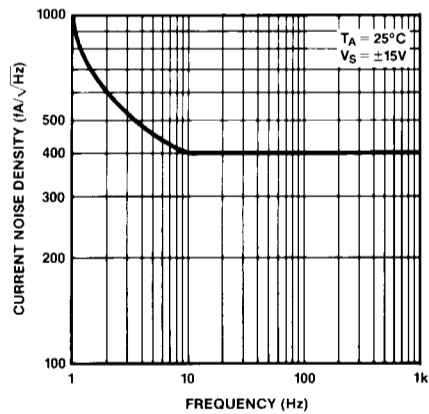

0.1Hz TO 10Hz NOISE

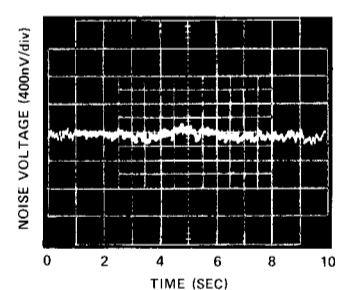

# OP200

## TYPICAL PERFORMANCE CHARACTERISTICS

**WARM-UP DRIFT**

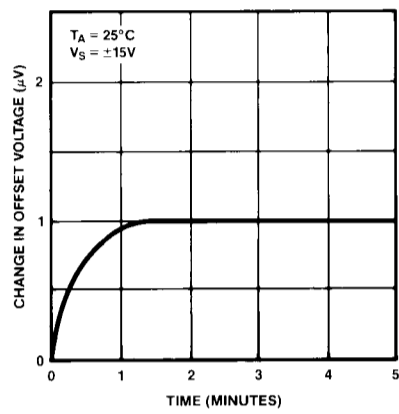

**INPUT OFFSET VOLTAGE vs TEMPERATURE**

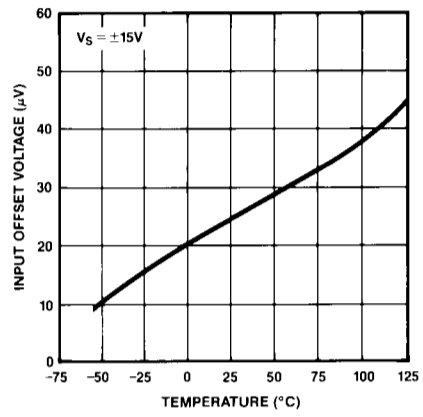

**INPUT BIAS CURRENT vs TEMPERATURE**

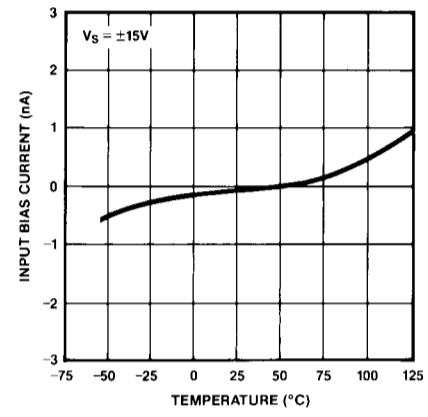

**INPUT OFFSET CURRENT vs TEMPERATURE**

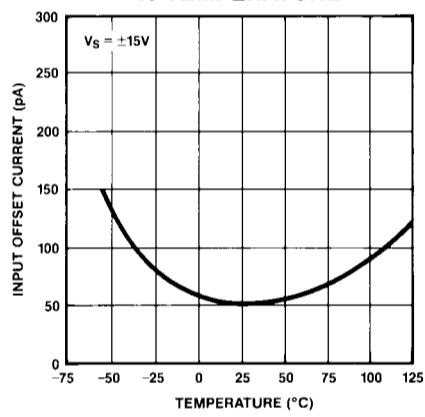

**INPUT BIAS CURRENT vs COMMON-MODE VOLTAGE**

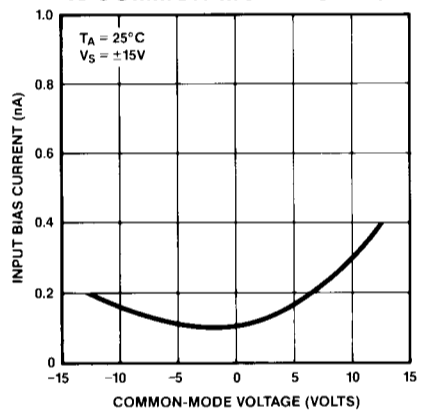

**COMMON-MODE REJECTION vs FREQUENCY**

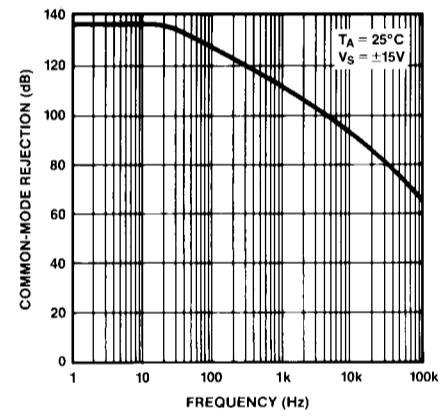

**VOLTAGE NOISE DENSITY vs FREQUENCY**

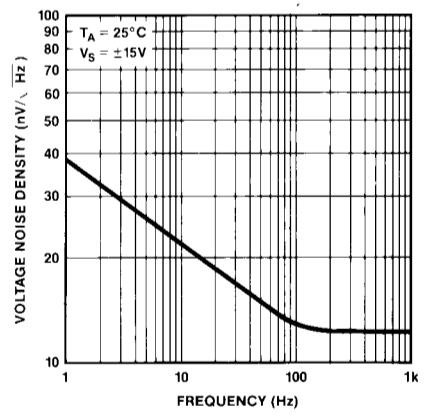

**CURRENT NOISE DENSITY vs FREQUENCY**

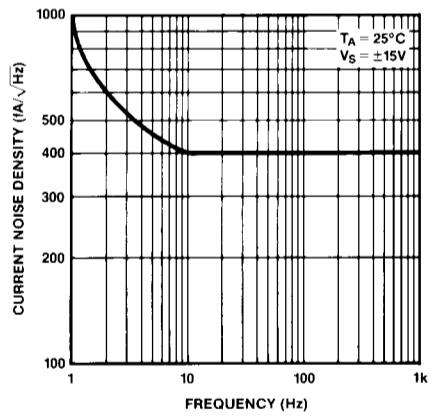

**0.1Hz TO 10Hz NOISE**

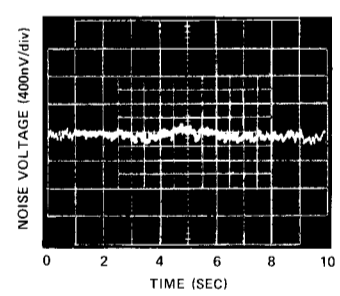

TYPICAL PERFORMANCE CHARACTERISTICS

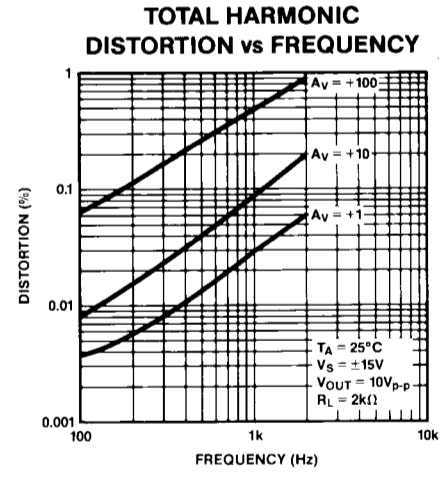
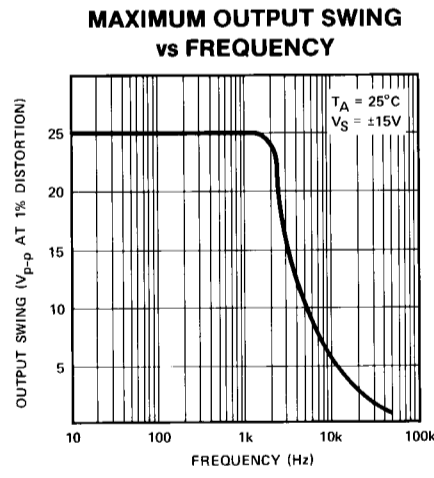
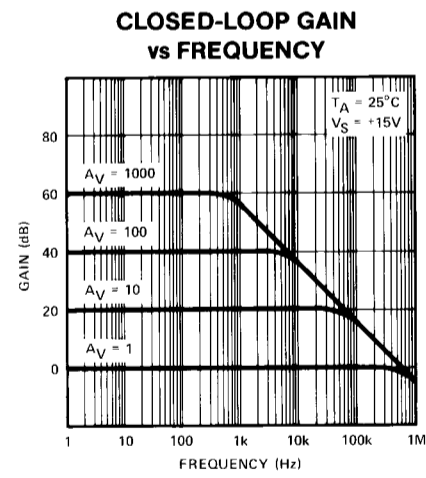
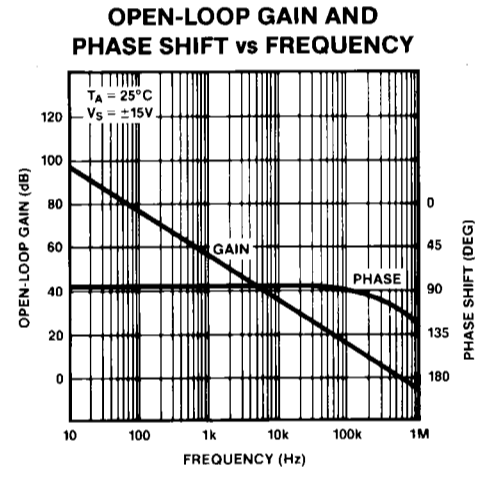
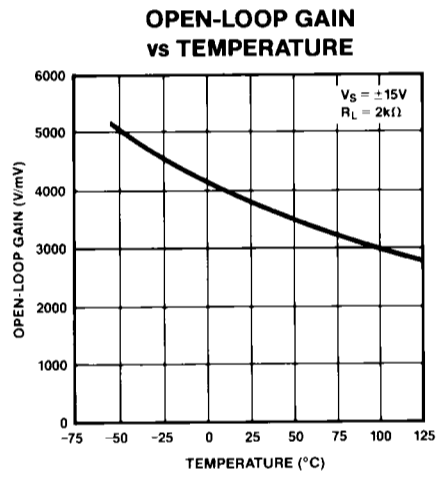
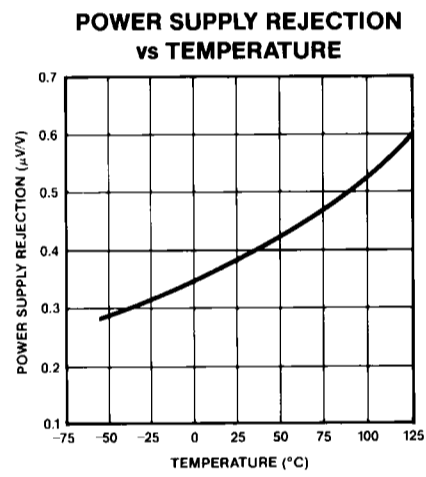
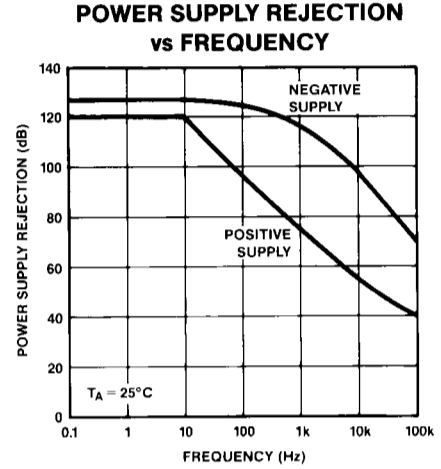
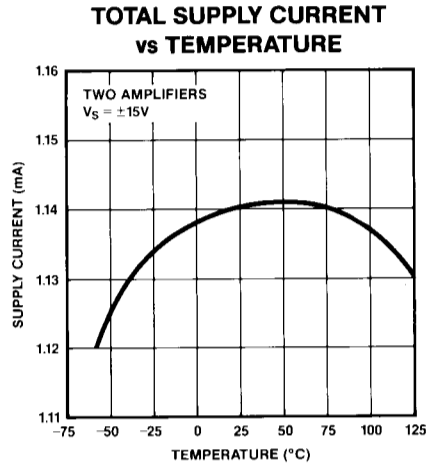
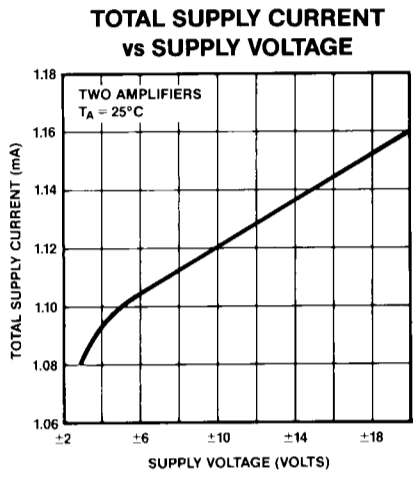

# OP200

## TYPICAL PERFORMANCE CHARACTERISTICS

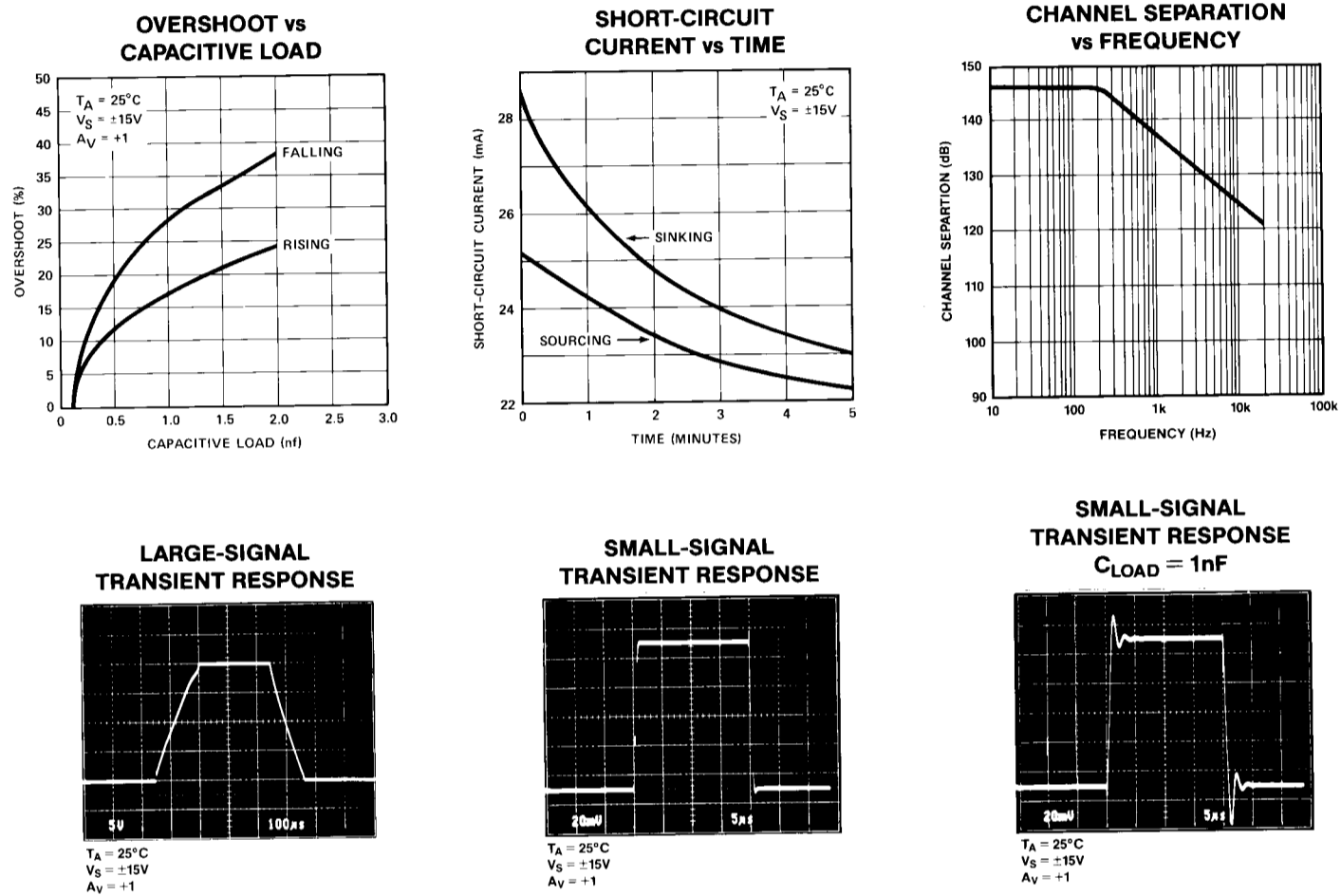

### APPLICATIONS INFORMATION

The OP-200 is inherently stable at all gains and is capable of driving large capacitive loads without oscillating. Nonetheless, good supply decoupling is highly recommended. Proper supply decoupling reduces problems caused by supply line noise and improves the capacitive load driving capability of the OP-200.

### APPLICATIONS

#### DUAL LOW-POWER INSTRUMENTATION AMPLIFIER

A dual instrumentation amplifier that consumes less than 33mW of power per channel is shown in Figure 1. The linearity of the instrumentation amplifier exceeds 16 bits in gains of 5 to 200 and is better than 14 bits in gains from 200 to 1000. CMRR is above 115dB (Gain = 1000). Offset voltage drift is typically  $0.2\mu\text{V}/^\circ\text{C}$  over the military temperature range which is comparable to the best monolithic instrumentation amplifiers. The

FIGURE 1: Dual Low-Power Instrumentation Amplifier

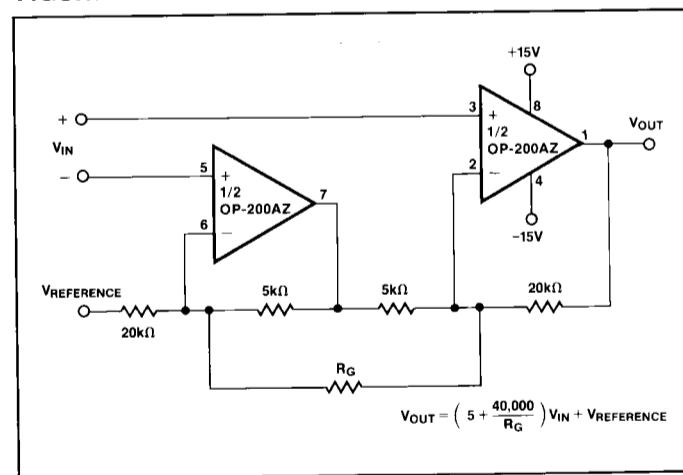



## OP200

bandwidth of the low-power instrumentation amplifier is a function of gain and is shown below:

GAIN	BANDWIDTH
5	150kHz
10	67kHz
100	7.5kHz
1000	500Hz

The output signal is specified with respect to the reference input, which is normally connected to analog ground. The reference input can be used to offset the output from  $-10\text{V}$  to  $+10\text{V}$  if required.

### PRECISION ABSOLUTE VALUE AMPLIFIER

The circuit of Figure 2 is a precision absolute value amplifier with an input impedance of  $10\text{M}\Omega$ . The high gain and low  $\text{TCV}_{\text{OS}}$  of the OP-200 insure accurate operation with microvolt

FIGURE 2. Precision Absolute Value Amplifier

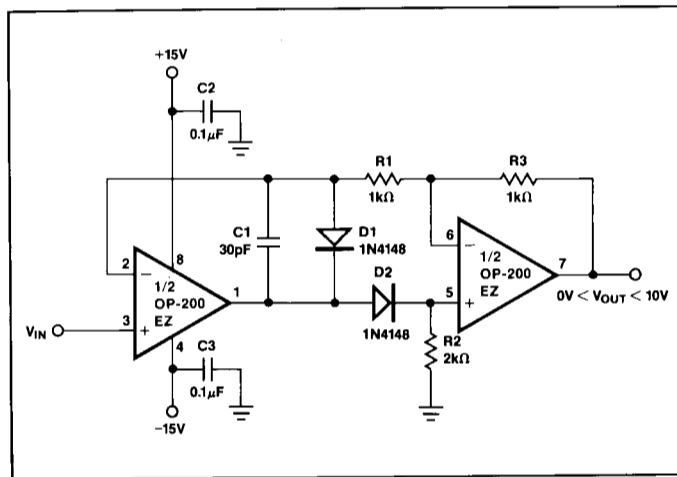
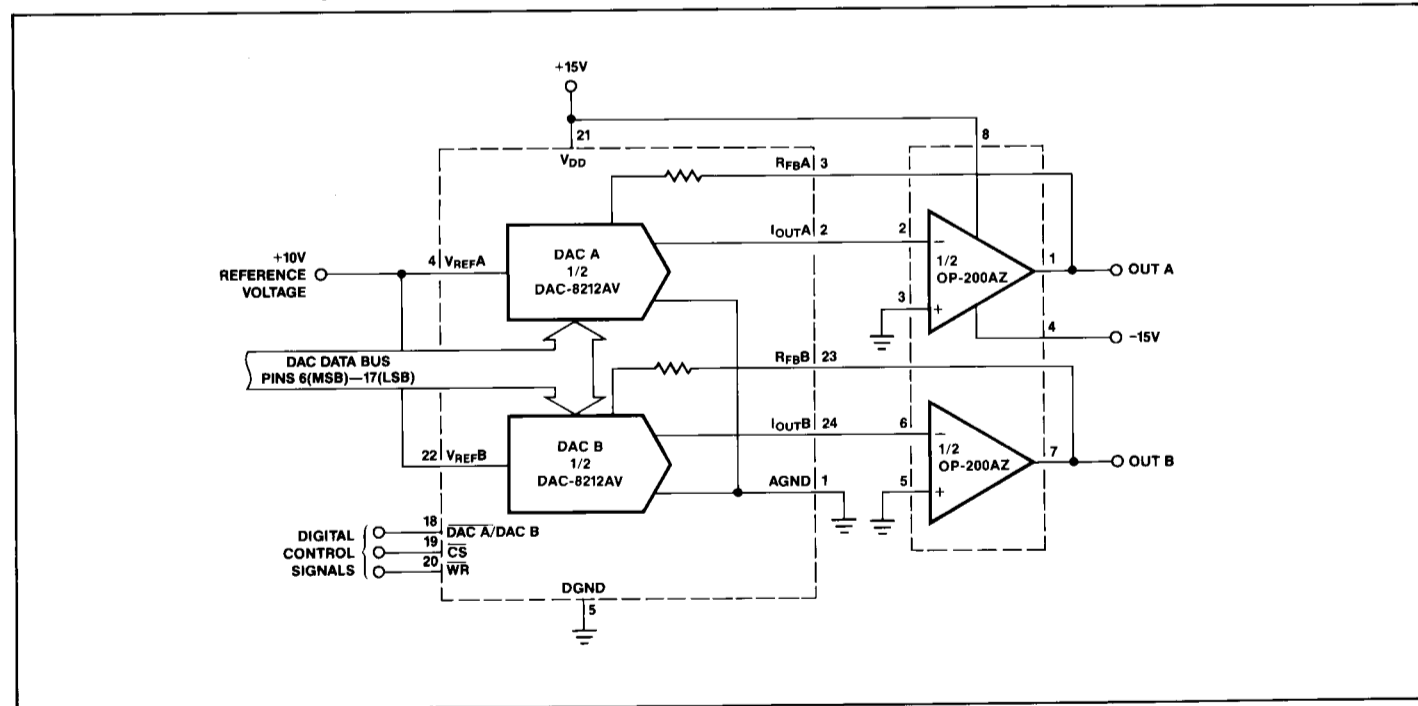

FIGURE 4. Dual 12-Bit Voltage Output DAC



input signals. In this circuit, the input always appears as a common-mode signal to the op amps. The CMR of the OP-200 exceeds 120dB, yielding an error of less than 2ppm.

### PRECISION CURRENT PUMP

Maximum output current of the precision current pump shown in Figure 3 is  $\pm 10\text{mA}$ . Voltage compliance is  $\pm 10\text{V}$  with  $\pm 15\text{V}$  supplies. Output impedance of the current transmitter exceeds  $3\text{M}\Omega$  with linearity better than 16 bits.

FIGURE 3. Precision Current Pump

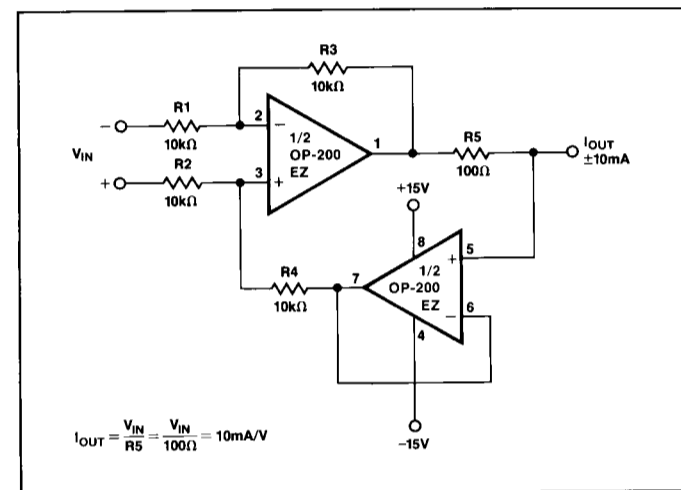

### DUAL 12-BIT VOLTAGE OUTPUT DAC

The dual output DAC shown in Figure 4 is capable of providing untrimmed 12-bit accurate operation over the entire military temperature range. Offset voltage, bias current and gain errors of the OP-200 contribute less than 1/10 of an LSB error at 12 bits over the military temperature range.

## OP200

### DUAL PRECISION VOLTAGE REFERENCE

A dual OP-200 and a REF-43, a 2.5V voltage reference, can be used to build a  $\pm 2.5V$  precision voltage reference. Maximum output current from each reference is  $\pm 10mA$  with load regulation under  $25\mu V/mA$ . Line regulation is better than  $15\mu V/V$  and output voltage drift is under  $20\mu V/^\circ C$ . Output voltage noise from 0.1Hz to 10Hz is typically  $75\mu V_{p-p}$ . R1 and D1 insure correct start-up.

### PROGRAMMABLE HIGH RESOLUTION WINDOW COMPARATOR

The programmable window comparator shown in Figure 6 is easily capable of 12-bit accuracy over the full military temperature range. A dual CMOS 12-bit DAC, the DAC-8212, is used in the voltage switching mode to set the upper and lower thresholds (DAC A and DAC B, respectively).

FIGURE 5. Dual Precision Voltage Reference

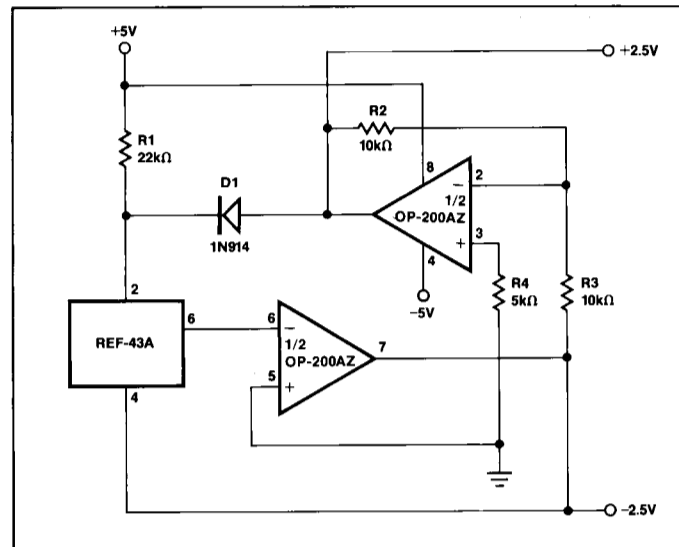

FIGURE 6. Programmable High Resolution Window Comparator

