

LED decoder/driver

NE587

DESCRIPTION

The NE587 is a latch/decoder/driver for 7-segment common anode LED displays. The NE587 has a programmable current output up to 50mA which is essentially independent of output voltage, power supply voltage, and temperature. The data (BCD) inputs and \overline{LE} (latch enable) input are low-loading so that they are compatible with any data bus system. The 7-segment decoding is implemented with a ROM so that alternative fonts can be made available.

FEATURES

- Latched BCD inputs
- Low loading bus-compatible inputs
- Ripple-blanking on leading- and/or trailing-edge zeros

APPLICATIONS

- Digital panel motors
- Measuring instruments
- Test equipment
- Digital clocks
- Digital bus monitoring

PIN CONFIGURATIONS

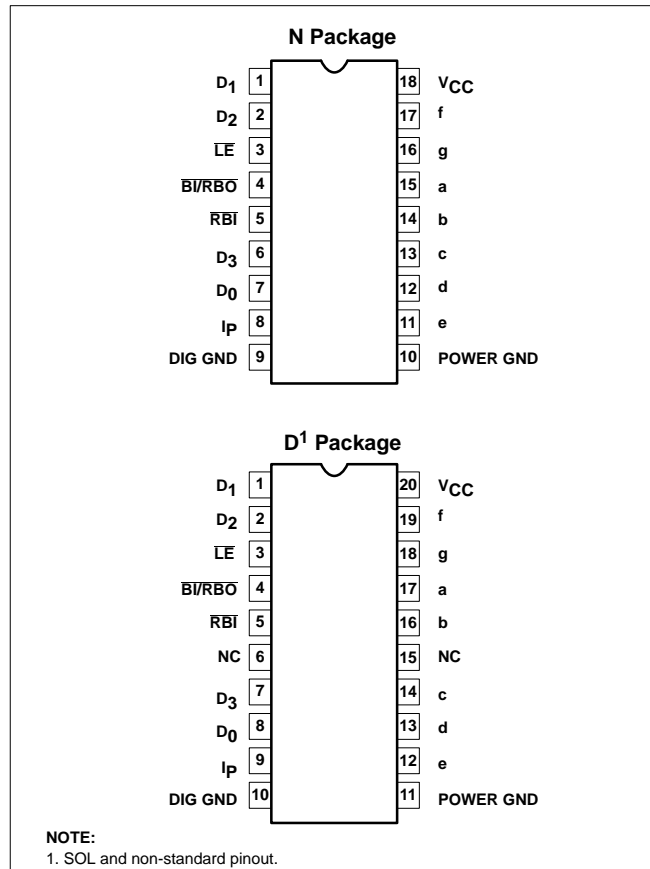

ORDERING INFORMATION

DESCRIPTION	TEMPERATURE RANGE	ORDER CODE	DWG #
20-Pin Plastic Small Outline Large (SOL) Package	0 to +70°C	NE587D ¹	0172D
18-Pin Plastic Dual In-Line Package (DIP)	0 to +70°C	NE587N	0407A

NOTES:

1. SOL and non-standard pinout

ABSOLUTE MAXIMUM RATINGS

T_A=25°C unless otherwise specified.

SYMBOL	PARAMETER	RATING	UNIT
V _{CC}	Supply voltage	-0.5 to +7	V
V _{IN}	Input voltage (D ₀ -D ₃ , \overline{LE} , \overline{RBI})	-0.5 to +15	V
V _{OUT}	Output voltage (a-g, RBO)	-0.5 to +7	V
P _D	Power dissipation (25°C) ¹	1000	mW
T _A	Ambient temperature range	0 to 70	°C
T _J	Junction temperature	150	°C
T _{STG}	Storage temperature range	-65 to +150	°C
T _{SOLD}	Soldering temperature (10sec max)	300	°C

NOTES:

1. Derate power dissipation as indicated
N package—95°C/W above 55°C

LED decoder/driver

NE587

BLOCK DIAGRAM

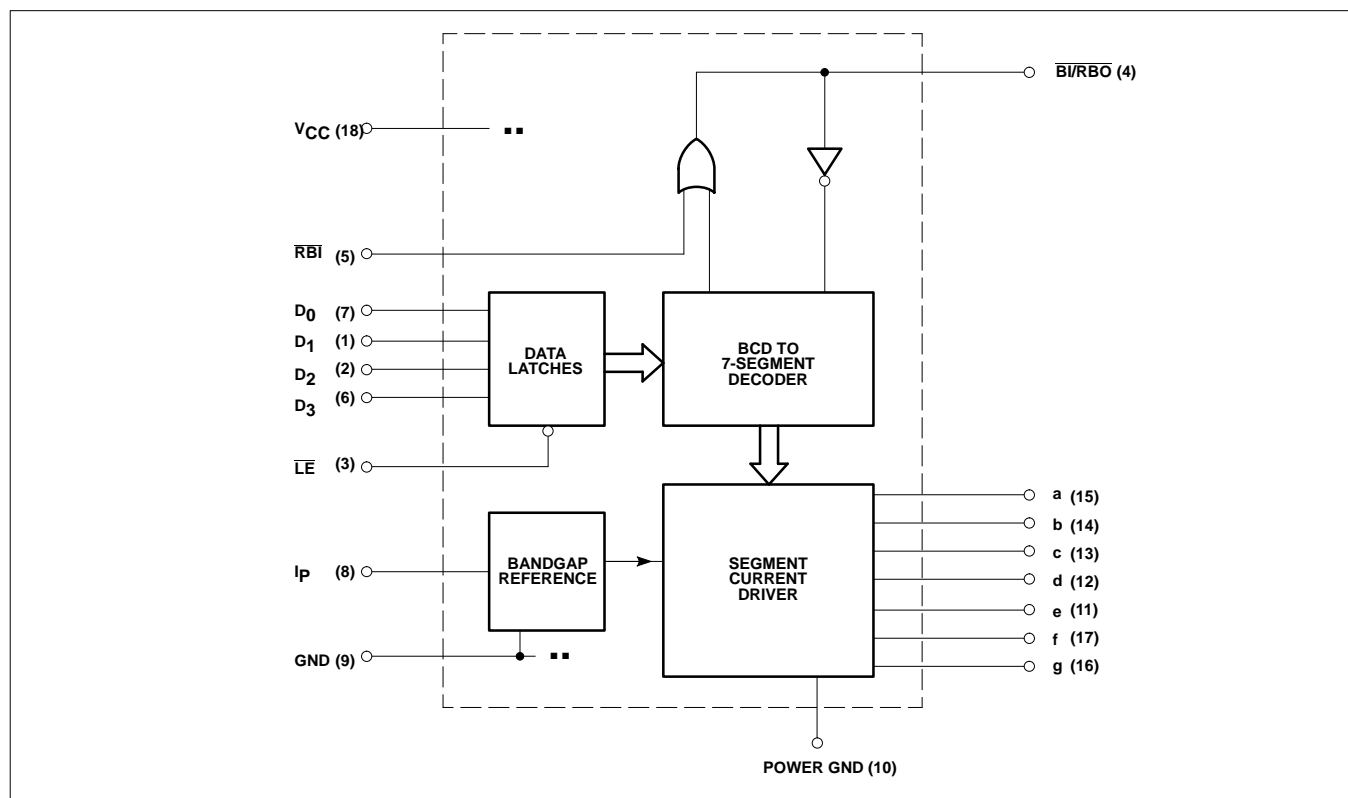

LED decoder/driver

NE587

DC ELECTRICAL CHARACTERISTICS

$V_{CC}=4.75$ to $5.25V$, $0^{\circ}C < T_A < 70^{\circ}C$. Typical values are at $V_{CC}=5V$, $T_A=25^{\circ}C$, $R_P=1k\Omega$ ($\pm 1\%$), unless otherwise specified.

SYMBOL	PARAMETER	TEST CONDITIONS	LIMITS			UNIT
			Min	Typ	Max	
V_{CC}	Operating supply voltage		4.75	5.00	5.25	V
V_{IH}	Input high voltage	All inputs except \overline{BI} \overline{BI}	2.0 2.0		15 5.5	V
V_{IL}	Input low voltage				0.8	V
V_{IC}	Input clamp voltage	$I_{IN}=-12mA$, $T_A=25^{\circ}C$			-1.5	V
I_{IH}	Input high current	Inputs D_0 - D_3 , \overline{LE} , $\overline{RB\overline{I}}$ $V_{IN}=2.4V$ $V_{IN}=15V$ Input \overline{BI} (Pin 4) $\overline{RB\overline{I}}=H$ $V_{IN}=V_{CC}=5.25V$		1.0 15 10	10 15 100	μA μA
I_{IL}	Input low current	$V_{IN}=0.4V$, Inputs D_0 - D_3 \overline{LE} , $\overline{RB\overline{I}}$ Input \overline{BI} $V_{CC}=5.25V$ $\overline{RB\overline{I}}=H$, $V_{IN}=0.4V$		-5 -200 -0.7		μA mA
V_{OL}	Output low voltage	Output \overline{RBO} $I_{OUT}=3.0mA$		0.2	0.5	V
V_{OH}	Output high voltage	Output \overline{RBO} $I_{OUT}=-50\mu A$ $\overline{RB\overline{I}}=H$	3.5	4.5		V
I_{OUT}	Output segment "ON" current	Outputs "a" through "g" $V_{OUT}=2.0V$	20	25	30	mA
ΔI_{OUT}	Output current ratio (all outputs ON)	With reference to "b" segment $V_{OUT}=2.0V$	0.90	1.00	1.10	
I_{OFF}	Output segment "OFF" current	Outputs "a" through "g" $V_{OUT}=5.0V$		20	250	μA
I_{CCO}	Supply current	$V_{CC}=5.25V$ All outputs "ON" $V_{OUT}>1V$		33	55	mA
I_{CCI}	Supply current	$V_{CC}=5.25V$ All outputs blanked		50	70	mA

NOTES:

NE587 Programming:

The NE587 output current can be programmed, provided a program resistor, R_P , be connected between I_P (Pin 8) and Ground (Pin 9). The voltage at I_P (Pin 8) is constant ($\approx 1.3V$). Thus, a current through R_P is $I_P \approx 1.3V/R_P$, as shown in Figure 5. I_O/I_P is 20 in the 15 to 50mA output current range.

LED decoder/driver

NE587

AC ELECTRICAL CHARACTERISTICS

$V_{CC}=5V$, $T_A=25^{\circ}C$, $R_L=130\Omega$, $C_L=30pF$ including probe capacity.

SYMBOL	PARAMETER	TEST CONDITIONS	LIMITS			UNIT
			Min	Typ	Max	
t_{DAV}	Propagation delay (Figure 2)	From data to output		135		ns
t_{DAV}	Propagation delay (Figure 3)	From \overline{LE} to output		135		ns
t_W	Latch enable pulse width (Figure 4)		30			ns
t_S	Latch enable setup time (Figure 4)	From data to \overline{LE}	20			ns
t_H	Latch enable hold time (Figure 4)	From \overline{LE} to data	0			ns

NOTES:

$t_{DAV} = (t_{HL} + t_{LH})$

TRUTH TABLE

BINARY INPUT	INPUTS						OUTPUTS									DISPLAY	
	\overline{LE}	\overline{RBI}	D_3	D_2	D_1	D_0	a	b	c	d	e	f	g	\overline{RBO}			
-	H	*	X	X	X	X	STABLE									**	STABLE
0	L	L	L	L	L	L	H	H	H	H	H	H	H	L	BLANK		
0	L	H	L	L	L	L	L	L	L	L	L	L	H	H	0		
1	L	X	L	L	L	H	H	L	L	H	H	H	H	H	1		
2	L	X	L	L	H	L	L	L	H	L	L	H	L	H	2		
3	L	X	L	L	H	H	L	L	L	L	H	H	L	H	3		
4	L	X	L	H	L	L	H	L	L	H	H	L	L	H	4		
5	L	X	L	H	L	H	L	H	L	L	H	L	L	H	5		
6	L	X	L	H	H	L	L	H	L	L	L	L	L	H	6		
7	L	X	L	H	H	H	L	L	L	H	H	H	H	H	7		
8	L	X	H	L	L	L	L	L	L	L	L	L	L	H	8		
9	L	X	H	L	L	H	L	L	L	L	H	L	L	H	9		
10	L	X	H	L	H	L	H	H	H	H	H	H	L	H	-		
11	L	X	H	L	H	H	L	H	H	L	L	L	L	H	E		
12	L	X	H	H	L	L	H	L	L	H	L	L	L	H	H		
13	L	X	H	H	L	H	H	H	H	L	L	L	H	H	L		
14	L	X	H	H	H	L	L	L	H	H	L	L	L	H	P		
15	L	X	H	H	H	H	H	H	H	H	H	H	H	H	Blank		
BI	X	X	X	X	X	X	H	H	H	H	H	H	H	L	Blank		

NOTES:

H=HIGH voltage level, output is "OFF"

L=LOW voltage level, output is "ON"

X=Don't care

* The RBI will blank the display only if a binary zero is stored in the latches.

** $\overline{RBO}/\overline{BI}$ used as an input overrides all other input conditions.

NE587 PROGRAMMING

587 output current can be programmed by using a programming resistor, RP, connected between RP (Pin 8) and GND (Pin 9). The voltage at RP (Pin 8) is constant ($\kappa = 1.3V$). A partial schematic of the voltage reference used in the NE587 is shown in Figure 1.

Output current to program current ratio, I_O/I_P , is 20 in the 15mA to 50mA range. Note that I_P must be derived from a resistor (R_P), and not from a high-impedance source such as an I_{OUT} DAC used to control display brightness.

POWER DISSIPATION CONSIDERATIONS

LED displays are power-hungry devices, and inevitably, somewhat inefficient in their use of the power supply necessary to drive them. Duty cycle control does afford one way of improving display efficiency, provided that the LEDs are not driven too far into saturation; but the improvement is marginal. Operation at higher peak currents has the added advantage of giving much better matching of light output, both from segment-to-segment and digit-to-digit.

LED decoder/driver

NE587

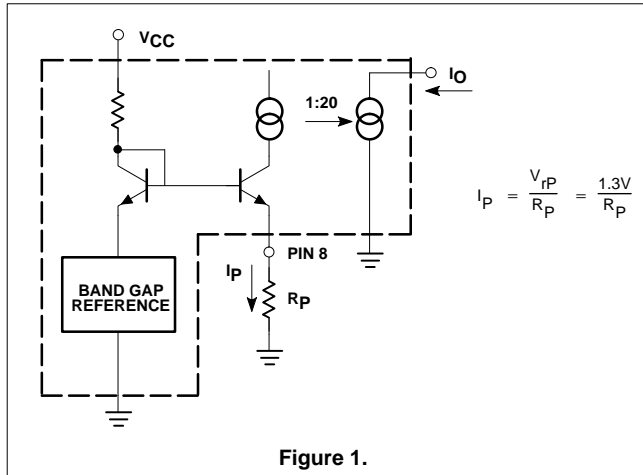

An output current of 10 to 50mA was chosen so that it would be suitable for multiplexed operation of large-size LED digits. When designing a display system, particular care must be taken to minimize power dissipation within the IC display driver. Since the output is a constant-current source, all the remaining supply voltage, which is not dropped across the LED (and the digit driver, if used), will appear across the output. Thus, the power dissipation will go up sharply if the display power supply voltage rises. Clearly, then, it is good design practice to keep the display supply voltage as low as possible, consistent with proper operation of the supply output current sources. Inserting a resistor or diode in series with the display supply is a good way of reducing the power dissipation within the integrated circuit segment driver, although, of course, total system power remains the same.

Power dissipation may be calculated as follows. Referring to Figure 6, the two system power supplies are V_{CC} and V_S . In many cases, these will be the same voltage. Necessary parameters are:

- V_{CC} Supply voltage to driver
- V_S Supply voltage to display
- I_{CC} Quiescent supply current of driver
- I_{SEG} LED segment current
- V_F LED segment forward voltage at I_{SEG}
- K_{DC} % Duty cycle

V_F , the forward LED drop, depends upon the type of LED material (hence the color) and the forward current. The actual forward voltage drops should be obtained from the LED display manufacturer's literature for the peak segment current selected; however, approximate voltages at nominal rated currents are:

- Red 1.6 to 2.0V
- Orange 2.0 to 2.5V
- Yellow 2.2 to 3.5V
- Green 2.5 to 3.5V

TIMING DIAGRAMS

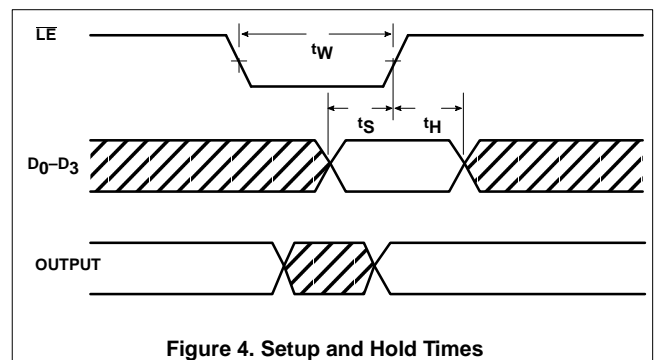
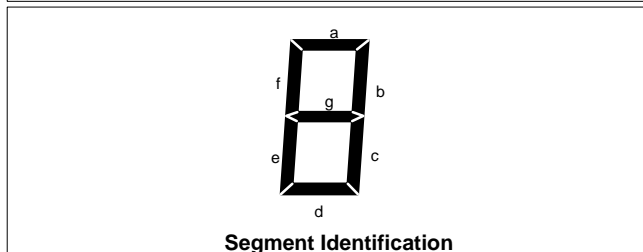
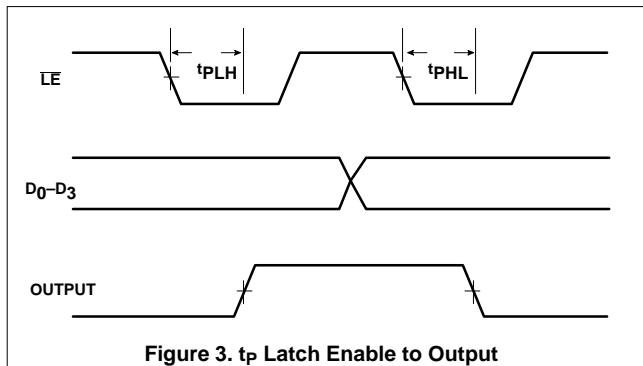
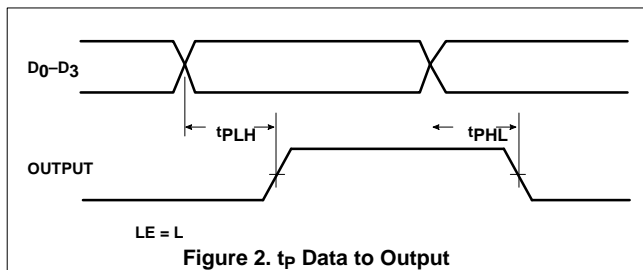

LED decoder/driver

NE587

TYPICAL PERFORMANCE CURVES

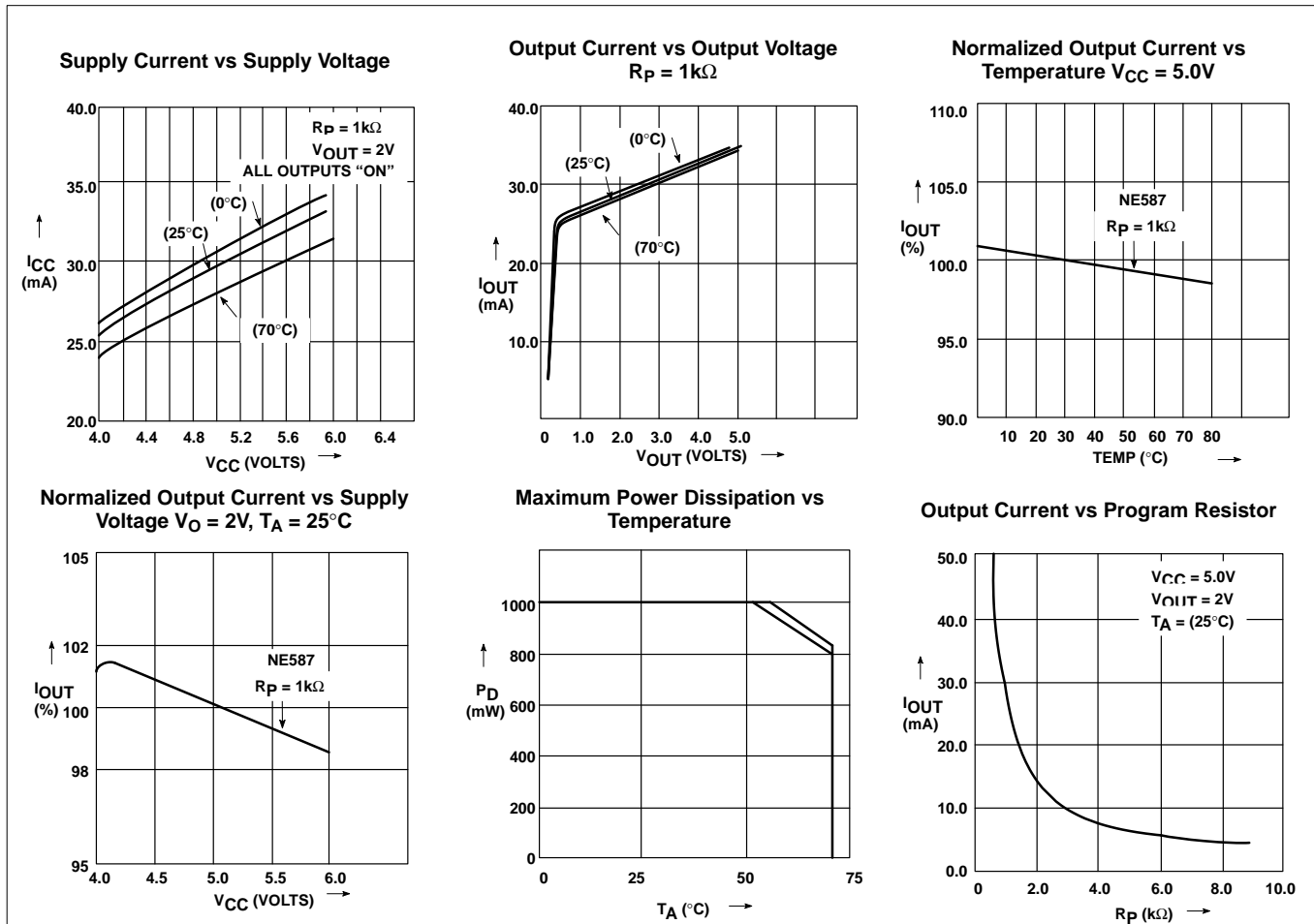

These voltages are all for single-diode displays. Some early red displays had 2 series LEDs per segment; hence the forward voltage drop was around 3.5V.

Thus, a maximum power dissipation calculation when all segments are on, is:

$$P_D = \frac{V_{CC} \times I_{CC} (V_S - V_F) \times 7 \times I_{SEG}}{K_{DC} \text{mW}}$$

Assuming $V_S = V_{CC} = 5.25V$
 $V_F = 2.0V$
 $K_{DC} = 100\%$

$$P_{D \text{ MAX}} = 5.25 \times 50 + 3.25 \times 7 \times 30 \text{mW} = 945 \text{mW}$$

However, the average power dissipation will be considerably less than this. Assuming 5 segments are on (the average for all output code combinations), then

$$P_{D \text{ MAX}} = 5.0 \times 30 + 3.00 \times 5 \times 25 \text{mW} = 525 \text{mW}$$

Operating temperature range limitations can be deduced from the power dissipation graph. (See Typical Performance Characteristics.)

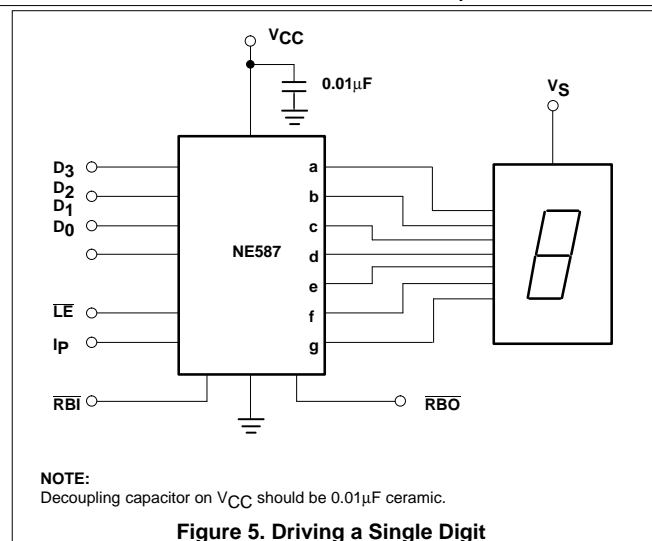

LED decoder/driver

NE587

However, a major portion of this power dissipation ($P_{D\ MAX}$) is because the current source output is operating with 3.25V across it. In practice, the outputs operate satisfactorily down to 0.5V, and so the extra voltage may be dropped external to the integrated circuit.

Suppose the worst-case V_{CC}/V_S supply is 4.75 to 5.25V, and that the maximum V_E for the LED display is 2.25V. Only 2.75V is required to keep the display active, and hence 2.0V may be dropped externally with a resistor from V_{CC} to V_S . The value of this resistor is calculated by:

$$R_S = \frac{2.0}{7 \times I_{SEG}} \quad 10\Omega \left(\frac{1}{2}W \text{ rating}\right)$$

assuming worst case I_{SEG} of 30mA.

Hence now

$$\begin{aligned} P_{D\ MAX} &= V_{CC} \times I_{CC} + \\ &\quad (V_S - V_V - R_X \times 7 \times I_{SEG}) \times 7 \times I_{SEG} \times K_{DC} \\ &= 5.25 \times 50 + 1.25 \times 7 \times 30mW \\ &= 525mW \end{aligned}$$

and

$$P_{D\ av} = 5.0 \times 30 + 1.25 \times 5 \times 25 = 306 \text{ mW.}$$

If a diode (or 2) is used to reduce voltage to the display, then the voltage appearing across the display driver will be independent of the number of "ON" segments and will be equal to

$$V_S - V_F - nV_d, \quad V_D \approx 0.8V$$

Where n is the number of diodes used, power dissipation can be calculated in a similar manner.

In a multiplexed display system, the voltage drop across the digit driver must also be considered in computing device power dissipation. It may even be an advantage to use a digit driver which

drops an appreciable voltage, rather than the saturating PNP transistors shown in Figure 9. For example a Darlington PNP or NPN emitter-follower may be preferable. Figure 8 shows the NE591 as the digit driver in a multiplexed display system. The NE591 output drops about 1.8V which means that the power dissipation is evenly distributed between the two integrated circuits.

Where V_S and V_{CC} are two different supplies, the V_S supply may be optimized for minimum system power dissipation and/or cost. Clearly, good regulation in the V_S supply is totally unnecessary, and so this supply can be made much cheaper than the regulated 5V supply used in the rest of the system. In fact, a simple unsmoothed full-wave rectified sine wave works extremely well if a slight loss in brightness can be tolerated. A transformer voltage of about 3-4.5V_{RMS} works well in most LED display systems. Waveforms are shown below:

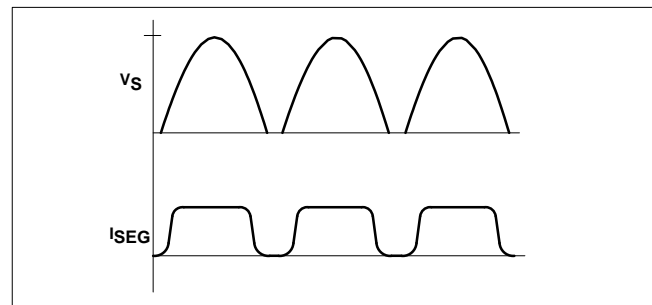

The duty cycle for this system depends upon V_S , V_F and the output characteristics of the display driver.

With

$$\begin{aligned} V_S &= 4.9V \text{ peak} \\ V_F &= 2.0V \end{aligned}$$

The duty cycle is approximately 60%.

LED decoder/driver

NE587

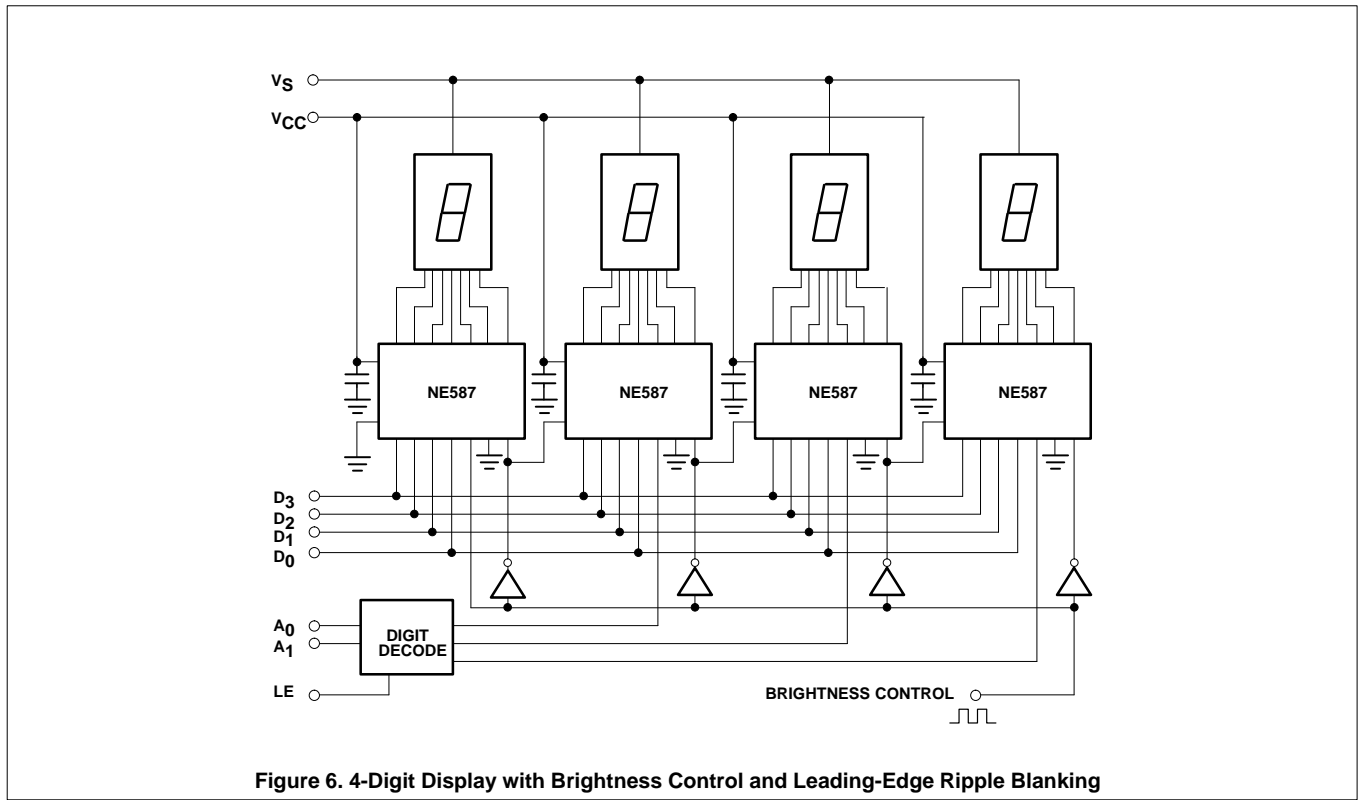

Figure 6. 4-Digit Display with Brightness Control and Leading-Edge Ripple Blanking

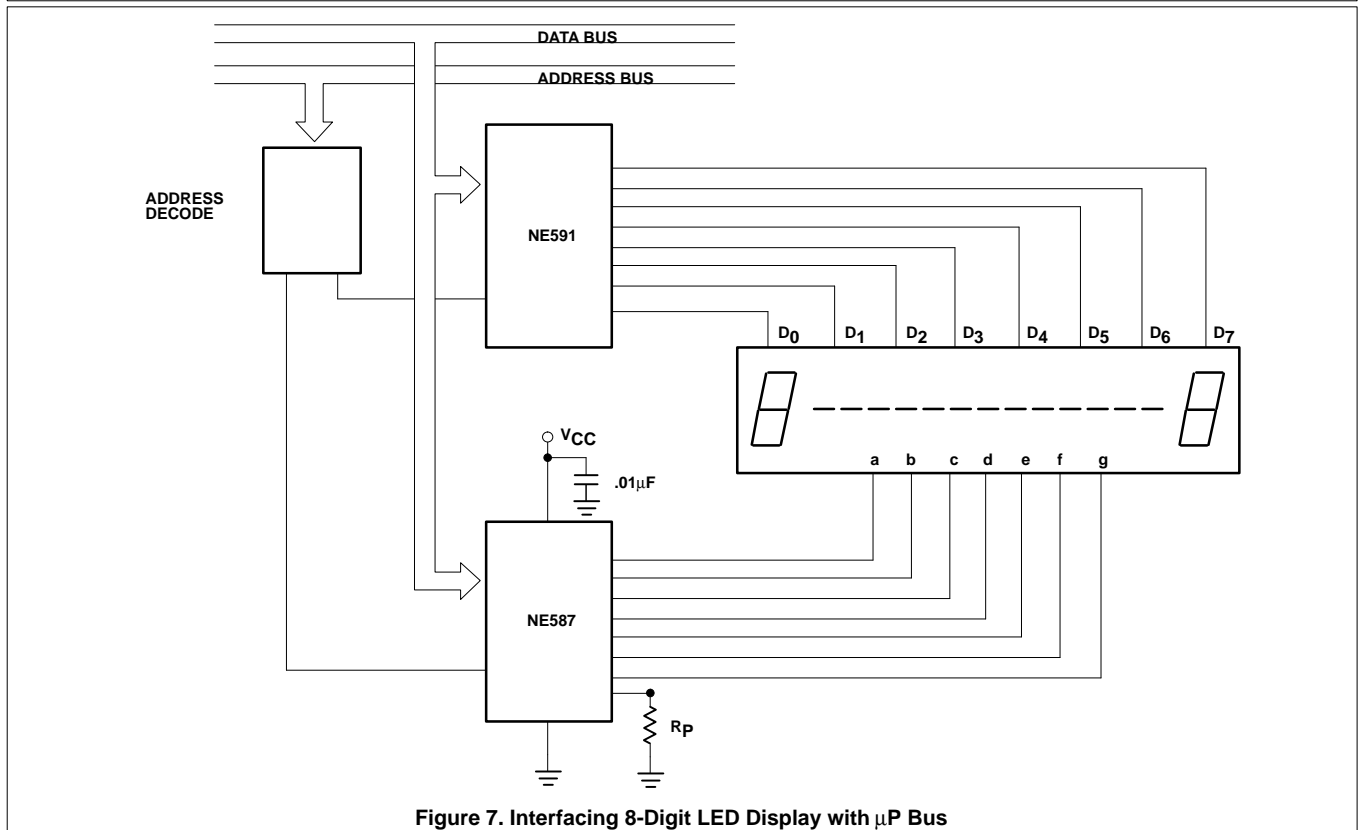

Figure 7. Interfacing 8-Digit LED Display with μ P Bus

LED decoder/driver

NE587

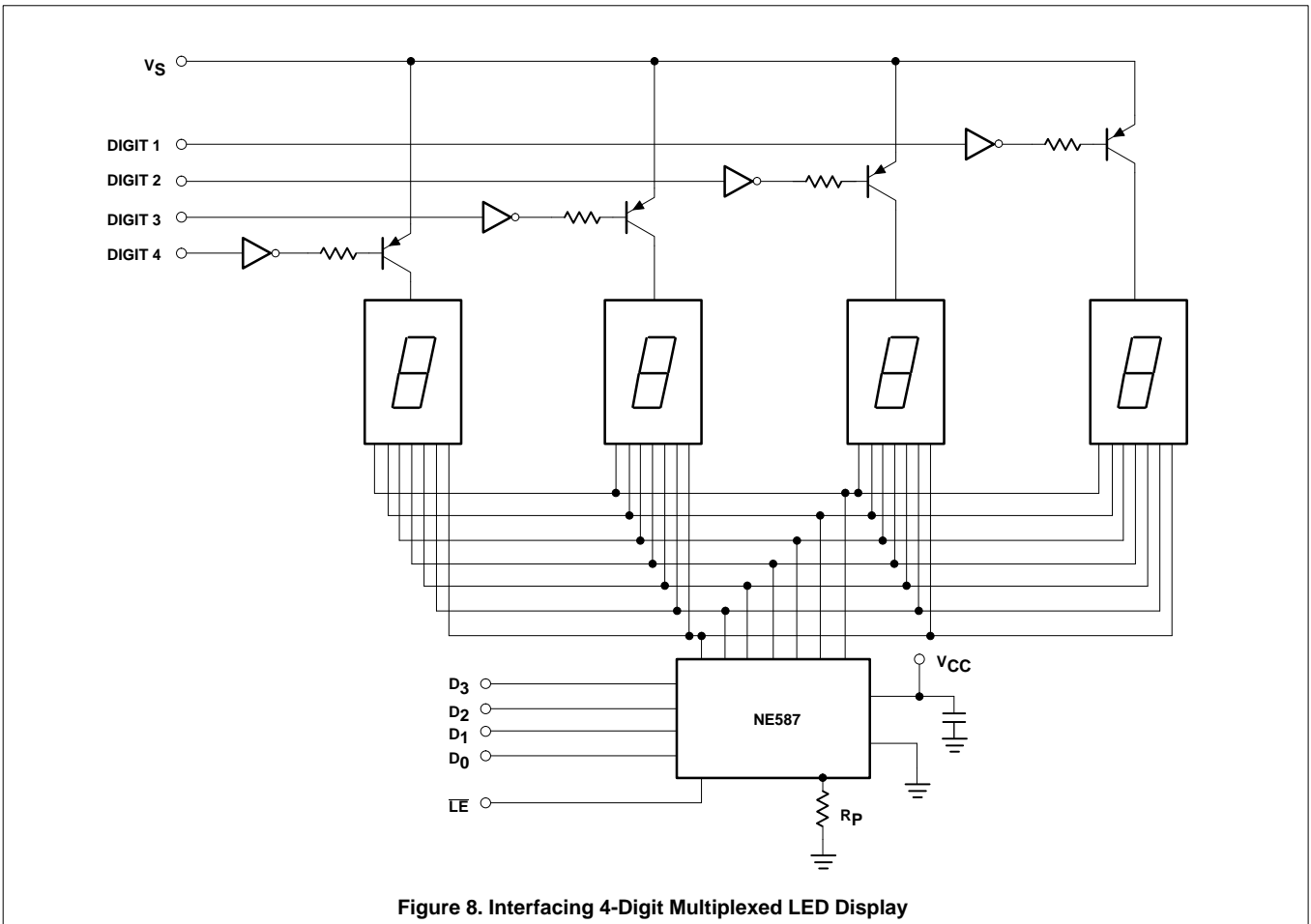

Figure 8. Interfacing 4-Digit Multiplexed LED Display