

**Specifications and Applications Information**

**VOICE SWITCHED SPEAKERPHONE CIRCUIT**

The MC34118 Voice Switched Speakerphone Circuit incorporates the necessary amplifiers, attenuators, level detectors, and control algorithm to form the heart of a high quality hands-free speakerphone system. Included are a microphone amplifier with adjustable gain and MUTE control, Transmit and Receive attenuators which operate in a complementary manner, level detectors at both input and output of both attenuators, and background noise monitors for both the transmit and receive channels. A Dial Tone Detector prevents the dial tone from being attenuated by the Receive background noise monitor circuit. Also included are two line driver amplifiers which can be used to form a hybrid network in conjunction with an external coupling transformer. A high-pass filter can be used to filter out 60 Hz noise in the receive channel, or for other filtering functions. A Chip Disable pin permits powering down the entire circuit to conserve power on long loops where loop current is at a minimum.

The MC34118 may be operated from a power supply, or it can be powered from the telephone line, requiring typically 5.0 mA. The MC34118 can be interfaced directly to Tip and Ring (through a coupling transformer) for stand-alone operation, or it can be used in conjunction with a handset speech network and/or other features of a featurephone.

- Improved Attenuator Gain Range: 52 dB Between Transmit and Receive
- Low Voltage Operation for Line-Powered Applications (3.0–6.5 V)
- 4-Point Signal Sensing for Improved Sensitivity
- Background Noise Monitors for Both Transmit and Receive Paths
- Microphone Amplifier Gain Set by External Resistors — Mute Function Included
- Chip Disable for Active/Standby Operation
- On Board Filter Pinned-Out for User Defined Function
- Dial Tone Detector to Inhibit Receive Idle Mode During Dial Tone Presence
- Standard 28-Pin Plastic DIP Package and SOIC Package Available
- Compatible with MC34119 Speaker Amplifier

**SIMPLIFIED BLOCK DIAGRAM**

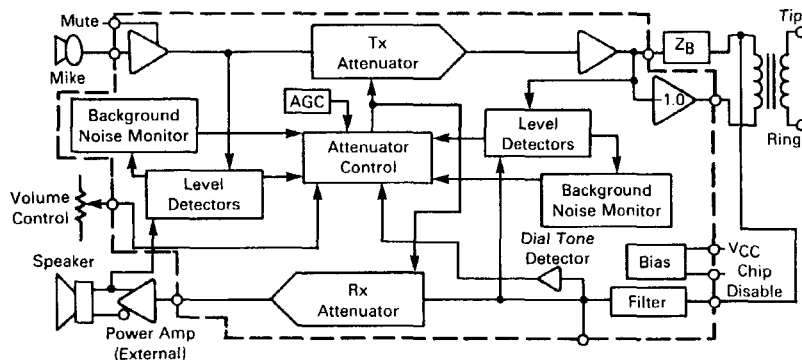

**MC34118**

**VOICE SWITCHED SPEAKERPHONE CIRCUIT**

**SILICON MONOLITHIC INTEGRATED CIRCUIT**

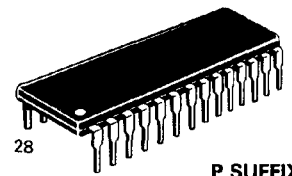

**P SUFFIX**  
**PLASTIC PACKAGE**  
**CASE 710**

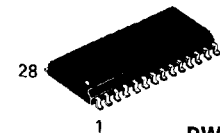

**DW SUFFIX**  
**PLASTIC PACKAGE**  
**CASE 751F**

**PIN CONNECTIONS**

(Top View)

FO	1	28	GND
FI	2	27	CPR
CD	3	26	RL1
VCC	4	25	RLO1
HTO+	5	24	TLO1
HTO-	6	23	TL1
HTI	7	22	R XO
TXO	8	21	R XI
TXI	9	20	RL2
MCO	10	19	RLO2
MCI	11	18	TLO2
MUT	12	17	TL2
VLC	13	16	CPT
CT	14	15	V <sub>B</sub>

(Pin assignments same for both packages)

**ABSOLUTE MAXIMUM RATINGS**

Parameter	Value	Units
Supply Voltage (Pin 4)	-1.0, +7.0	Vdc
Voltage at CD (Pin 3), MUT (Pin 12)	-1.0, V <sub>CC</sub> + 1.0	Vdc
Voltage at VLC (Pin 13)	-1.0, V <sub>CC</sub> + 0.5	Vdc
Voltage at TXI (Pin 9), RXI (Pin 21), FI (Pin 2)	-0.5, V <sub>CC</sub> + 0.5	Vdc
Storage Temperature Range	-65 to +150	°C

Devices should not be operated at or outside these values. The "Recommended Operating Limits" provide for actual device operation.

**RECOMMENDED OPERATING LIMITS**

Parameter	Min	Typ	Max	Units
Supply Voltage (Pin 4) (See Text)	3.5	—	6.5	Vdc
CD Input (Pin 3), MUT Input (Pin 12)	0	—	V <sub>CC</sub>	Vdc
I <sub>VB</sub> Current (Pin 15)	—	—	500	μA
VLC (Pin 13)	0.3 × V <sub>B</sub>	—	V <sub>B</sub>	Vdc
Attenuator Input Signal Voltage (Pins 9, 21)	0	—	350	mVrms
Microphone Amplifier, Hybrid Amplifier Gain	0	—	40	dB
Load Current @ RXO, TXO (Pins 8, 22)	0	—	±2.0	mA
@ MCO (Pin 10)	0	—	±1.0	
@ HTO-, HTO+ (Pins 6, 5)	0	—	±5.0	
Ambient Operating Temperature Range	-20	—	+60	°C

**ELECTRICAL CHARACTERISTICS** (T<sub>A</sub> = +25°C, V<sub>CC</sub> = 5.0 V, CD ≤ 0.8 V, unless noted)

Parameter	Symbol	Min	Typ	Max	Units
<b>POWER SUPPLY</b>					
V <sub>CC</sub> Supply Current (V <sub>CC</sub> = 6.5 V, CD = 0.8 V)	I <sub>CC</sub>	—	5.5	8.0	mA
(V <sub>CC</sub> = 6.5 V, CD = 2.0 V)		—	600	800	μA
CD Input Resistance (V <sub>CC</sub> = V <sub>CD</sub> = 6.5 V)	R <sub>CD</sub>	50	90	—	kΩ
CD Input Voltage — High	V <sub>CDH</sub>	2.0	—	V <sub>CC</sub>	Vdc
— Low	V <sub>CDL</sub>	0	—	0.8	Vdc
V <sub>B</sub> Output Voltage (V <sub>CC</sub> = 3.5 V)	V <sub>B</sub>	—	1.3	—	Vdc
(V <sub>CC</sub> = 5.0 V)		1.8	2.1	2.4	
V <sub>B</sub> Output Resistance (I <sub>VB</sub> = 1.0 mA)	R <sub>OVB</sub>	—	400	—	Ω
V <sub>B</sub> Power Supply Rejection Ratio (C <sub>VB</sub> = 220 μF, f = 1.0 kHz)	PSRR	—	54	—	dB

**ATTENUATORS** (T<sub>A</sub> = +25°C)

Receive Attenuator Gain (f = 1.0 kHz, V <sub>LC</sub> = V <sub>B</sub> )					dB
Rx Mode, RXI = 150 mVrms (V <sub>CC</sub> = 5.0 V)	GRX	+4.0	+6.0	+8.0	
Rx Mode, RXI = 150 mVrms (V <sub>CC</sub> = 3.5 V)	GRX	+4.0	+6.0	+8.0	
Gain Change - V <sub>CC</sub> = 3.5 V versus V <sub>CC</sub> = 5.0 V	ΔGRX1	-0.5	0	+0.5	
AGC Gain Change - V <sub>CC</sub> = 2.8 V versus V <sub>CC</sub> = 5.0 V*	ΔGRX2	—	-25	-15	
Idle Mode, RXI = 150 mVrms	GRXI	-22	-20	-17	
Range (Rx to Tx Mode)	ΔGRX3	49	52	54	
Volume Control Range (Rx Mode, 0.3 V <sub>B</sub> < V <sub>LC</sub> < V <sub>B</sub> )	V <sub>CR</sub>	27	35	—	dB
RXO DC Voltage (Rx Mode)	V <sub>RXO</sub>	—	V <sub>B</sub>	—	Vdc
ΔRXO DC Voltage (Rx to Tx Mode)	ΔV <sub>RXO</sub>	—	±10	±150	mV
RXO High Voltage (I <sub>out</sub> = -1.0 mA, RXI = V <sub>B</sub> + 1.5 V)	V <sub>RXOH</sub>	3.7	—	—	Vdc
RXO Low Voltage (I <sub>out</sub> = +1.0 mA, RXI = V <sub>B</sub> - 1.0, Output measured with respect to V <sub>B</sub> )*	V <sub>RXOL</sub>	—	-1.5	-1.0	Vdc
RXI Input Resistance (RXI < 350 mVrms)	R <sub>RXI</sub>	7.0	10	14	kΩ

(continued)

**ELECTRICAL CHARACTERISTICS** ( $T_A = +25^\circ\text{C}$ ,  $V_{CC} = 5.0\text{ V}$ ,  $CD \leq 0.8\text{ V}$ , unless noted)

Parameter	Symbol	Min	Typ	Max	Units
<b>ATTENUATORS — continued</b> ( $T_A = +25^\circ\text{C}$ )					
Transmit Attenuator Gain ( $f = 1.0\text{ kHz}$ ) Tx Mode, $TXI = 150\text{ mVrms}$ Idle Mode, $TXI = 150\text{ mVrms}$ Range (Tx to Rx Mode)	GTX GTXI $\Delta GTXI$	+4.0 -22 49	+6.0 -20 52	+8.0 -17 54	dB
TXO DC Voltage (Tx Mode)	$V_{TXO}$	—	$V_B$	—	Vdc
$\Delta TXO$ DC Voltage (Tx to Rx Mode)	$\Delta V_{TXO}$	—	$\pm 30$	$\pm 150$	mV
TXO High Voltage ( $I_{out} = -1.0\text{ mA}$ , $TXI = V_B + 1.5\text{ V}$ )	$V_{TXOH}$	3.7	—	—	Vdc
TXO Low Voltage ( $I_{out} = +1.0\text{ mA}$ , $TXI = V_B - 1.0\text{ V}$ , Output measured with respect to $V_B$ )*	$V_{TXOL}$	—	-1.5	-1.0	Vdc
TXI Input Resistance ( $TXI < 350\text{ mVrms}$ )	$R_{TXI}$	7.0	10	14	k $\Omega$
Gain Tracking ( $G_{RX} + G_{TX}$ , @ Tx, Idle, Rx)*	GTR	—	$\pm 0.1$	—	dB

\*See text for explanation.

**ATTENUATOR CONTROL** ( $T_A = +25^\circ\text{C}$ )

$C_T$ Voltage (Pin 14 - $V_B$ ) Rx Mode ( $V_{LC} = V_B$ ) Idle Mode Tx Mode	$V_{CT}$	— — —	+240 0 -240	— — —	mV
$C_T$ Source Current (switching to Rx mode)	$I_{CTR}$	-85	-60	-40	$\mu\text{A}$
$C_T$ Sink Current (switching to Tx mode)	$I_{CTT}$	+40	+60	+85	$\mu\text{A}$
$C_T$ Slow Idle Current	$I_{CTS}$	—	0	—	$\mu\text{A}$
$C_T$ Fast Idle Internal Resistance	$R_{FI}$	1.5	2.0	3.6	k $\Omega$
$V_{LC}$ Input Current	$I_{VLC}$	—	-60	—	nA
Dial Tone Detector Threshold	$V_{DT}$	10	15	20	mV

**MICROPHONE AMPLIFIER** ( $T_A = +25^\circ\text{C}$ ,  $V_{MUT} \leq 0.8\text{ V}$ ,  $AV_{CL} = 31\text{ dB}$  unless otherwise noted)

Output Offset ( $V_{MCO} - V_B$ , Feedback $R = 180\text{ k}\Omega$ )	$MCOVOS$	-50	0	+50	mVdc
Open Loop Gain ( $f < 100\text{ Hz}$ )	$AVOLM$	70	80	—	dB
Gain Bandwidth	$GBW_M$	—	1.0	—	MHz
Output High Voltage ( $I_{out} = -1.0\text{ mA}$ , $V_{CC} = 5.0\text{ V}$ )	$V_{MCOH}$	3.7	—	—	Vdc
Output Low Voltage ( $I_{out} = +1.0\text{ mA}$ )	$V_{MCOL}$	—	—	200	mVdc
Input Bias Current (@ MCI)	$I_{BM}$	—	-40	—	nA
Muting ( $\Delta$ Gain) ( $f = 1.0\text{ kHz}$ , $V_{MUT} = 2.0\text{ V}$ ) ( $300\text{ Hz} < f < 10\text{ kHz}$ )	GMT	-55 —	— -68	— —	dB
MUT Input Resistance ( $V_{CC} = V_{MUT} = 6.5\text{ V}$ )	$R_{MUT}$	50	90	—	k $\Omega$
MUT Input — High	$V_{MUTH}$	2.0	—	$V_{CC}$	Vdc
MUT Input — Low	$V_{MUTL}$	0	—	0.8	Vdc
Distortion ( $300\text{ Hz} < f < 10\text{ kHz}$ )	THDM	—	0.15	—	%

**HYBRID AMPLIFIERS** ( $T_A = +25^\circ\text{C}$ )

HTO- Offset ( $V_{HTO-} - V_B$ , Feedback $R = 51\text{ k}\Omega$ )	$HVOS$	-20	0	+20	mVdc
HTO- to HTO+ Offset (Feedback $R = 51\text{ k}\Omega$ )	$HBVOS$	-30	0	+30	mVdc
Open Loop Gain (HTI to HTO-, $f < 100\text{ Hz}$ )	$AVOLH$	60	80	—	dB
Gain Bandwidth	$GBW_H$	—	1.0	—	MHz
Closed Loop Gain (HTO- to HTO+)	$AVCLH$	-0.35	0	+0.35	dB
Input Bias Current (@HTI)	$I_{BH}$	—	-30	—	nA
HTO- High Voltage ( $I_{out} = -5.0\text{ mA}$ )	$V_{HT-H}$	3.7	—	—	Vdc
HTO- Low Voltage ( $I_{out} = +5.0\text{ mA}$ )	$V_{HT-L}$	—	—	250	mVdc
HTO+ High Voltage ( $I_{out} = -5.0\text{ mA}$ )	$V_{HT+H}$	3.7	—	—	Vdc
HTO+ Low Voltage ( $I_{out} = +5.0\text{ mA}$ )	$V_{HT+L}$	—	—	450	mVdc
Distortion ( $300\text{ Hz} < f < 10\text{ kHz}$ , See Figure 1)	THDH	—	0.3	—	%

Parameter	Symbol	Min	Typ	Max	Units
<b>LEVEL DETECTORS AND BACKGROUND NOISE MONITORS (T<sub>A</sub> = +25°C)</b>					
Transmit-Receive Switching Threshold (Ratio of Current at RLI1 + RLI2 to 20 μA at TLI1 + TLI2 to switch from Tx to Rx)	I <sub>TH</sub>	0.8	1.0	1.2	
Source Current at RLO1, RLO2, TLO1, TLO2	I <sub>LSO</sub>	—	-2.0	—	mA
Sink Current at RLO1, RLO2, TLO1, TLO2	I <sub>LSK</sub>	—	4.0	—	μA
CPR, CPT Output Resistance (I <sub>out</sub> = 1.5 mA)	R <sub>CP</sub>	—	35	—	Ω
CPR, CPT Leakage Current	I <sub>CPLK</sub>	—	-0.2	—	μA
<b>FILTER (T<sub>A</sub> = +25°C)</b>					
Voltage Offset at FO (V <sub>FO</sub> - V <sub>B</sub> , 220 kΩ from V <sub>B</sub> to FI)	FO <sub>VOS</sub>	-200	-90	0	mV
FO Sink Current	I <sub>FO</sub>	150	260	400	μA
FI Bias Current	I <sub>FI</sub>	—	-50	—	nA
<b>SYSTEM DISTORTION (T<sub>A</sub> = +25°C, f = 1.0 kHz)</b>					
Rx Mode (From FI to RXO, FO connected to RXI)	THD <sub>R</sub>	—	0.5	3.0	%
Tx Mode (From MCI to HTO - /HTO +, includes Tx attenuator)	THD <sub>T</sub>	—	0.8	3.0	%

1. All currents into a device pin are positive, those out of a pin are negative. Algebraic convention rather than magnitude is used to define limits.

FIGURE 1 — HYBRID AMPLIFIER DISTORTION TEST

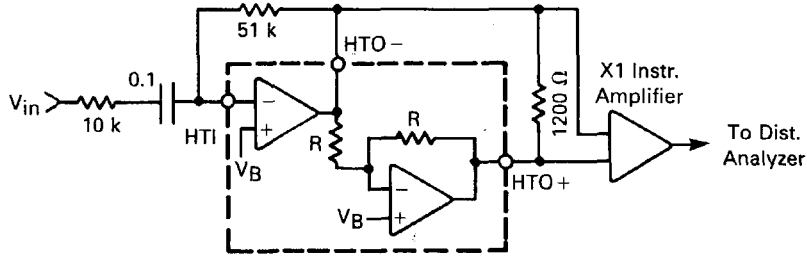

TEMPERATURE CHARACTERISTICS

Parameter	Typical Value @ 25°C	Typical Change -20 to +60°C
V <sub>CC</sub> Supply Current (CD = 0.8 V)	5.0 mA	-0.3 %/°C
V <sub>CC</sub> Supply Current (CD = 2.0 V)	400 μA	-0.4 %/°C
V <sub>B</sub> Output Voltage (V <sub>CC</sub> = 5.0 V)	2.1 V	+0.8 %/°C
Attenuator Gain (Max Gain)	+6.0 dB	0.0008 dB/°C
Attenuator Gain (Max Attenuation)	-46 dB	0.004 dB/°C
Attenuator Input Resistance (@ TXI, RXI)	10 kΩ	+0.6 %/°C
Dial Tone Detector Threshold	15 mV	+20 μV/°C
CT Source, Sink Current	±60 μA	-0.15 %/°C
Microphone, Hybrid Amplifier Offset	0 mV	±4.0 μV/°C
Transmit-Receive Switching Threshold	1.0	±0.02 %/°C
Sink Current at RLO1, RLO2, TLO1, TLO2	4.0 μA	-10 nA/°C
Closed Loop Gain (HTO - to HTO +)	0 dB	0.001 %/°C

## PIN DESCRIPTION

Pin	Name	Description
1	FO	Filter output. Output impedance is less than 50 ohms.
2	FI	Filter input. Input impedance is greater than 1.0 Mohm.
3	CD	Chip Disable. A logic low (<0.8 V) sets normal operation. A logic high (>2.0 V) disables the IC to conserve power. Input impedance is nominally 90 k $\Omega$ .
4	VCC	A supply voltage of +2.8 to +6.5 volts is required, at $\approx$ 5.0 mA. As VCC falls from 3.5 to 2.8 volts, an AGC circuit reduces the receive attenuator gain by $\approx$ 25 dB (when in the receive mode).
5	HTO+	Output of the second hybrid amplifier. The gain is internally set at $-1.0$ to provide a differential output, in conjunction with HTO-, to the hybrid transformer.
6	HTO-	Output of the first hybrid amplifier. The gain of the amp is set by external resistors.
7	HTI	Input and summing node for the first hybrid amplifier. DC level is $\approx$ V <sub>B</sub> .
8	TXO	Output of the transmit attenuator. DC level is approximately V <sub>B</sub> .
9	TXI	Input to the transmit attenuator. Max. signal level is 350 mVrms. Input impedance is $\approx$ 10 k $\Omega$ .
10	MCO	Output of the microphone amplifier. The gain of the amplifier is set by external resistors.
11	MCI	Input and summing node of the microphone amplifier. DC level is $\approx$ V <sub>B</sub> .
12	MUT	Mute input. A logic low (<0.8 V) sets normal operation. A logic high (>2.0 V) mutes the microphone amplifier without affecting the rest of the circuit. Input impedance is nominally 90 k $\Omega$ .

Pin	Name	Description
13	VLC	Volume control input. When VLC = V <sub>B</sub> , the receive attenuator is at maximum gain when in the receive mode. When VLC = 0.3 V <sub>B</sub> , the receive gain is down 35 dB. Does not affect the transmit mode.
14	C <sub>T</sub>	An RC at this pin sets the response time for the circuit to switch modes.
15	V <sub>B</sub>	An output voltage $\approx$ VCC/2. This voltage is a system ac ground, and biases the volume control. A filter cap is required.
16	CPT	An RC at this pin sets the time constant for the transmit background monitor.
17	TLI2	Input to the transmit level detector on the mike/speaker side.
18	TLO2	Output of the transmit level detector on the mike/speaker side, and input to the transmit background monitor.
19	RLO2	Output of the receive level detector on the mike/speaker side.
20	RLI2	Input to the receive level detector on the mike/speaker side.
21	RXI	Input to the receive attenuator and dial tone detector. Max input level is 350 mV RMS. Input impedance is $\approx$ 10 k $\Omega$ .
22	RXO	Output of the receive attenuator. DC level is approximately V <sub>B</sub> .
23	TLI1	Input to the transmit level detector on the line side.
24	TLO1	Output of the transmit level detector on the line side.
25	RLO1	Output of the receive level detector on the line side, and input to the receive background monitor.
26	RLI1	Input to the receive level detector on the line side.
27	CPR	An RC at this pin sets the time constant for the receive background monitor.
28	GND	Ground pin for the entire IC.

Note: Pin numbers are identical for the DIP package and the SOIC package.

FIGURE 2 — MC34118 BLOCK DIAGRAM

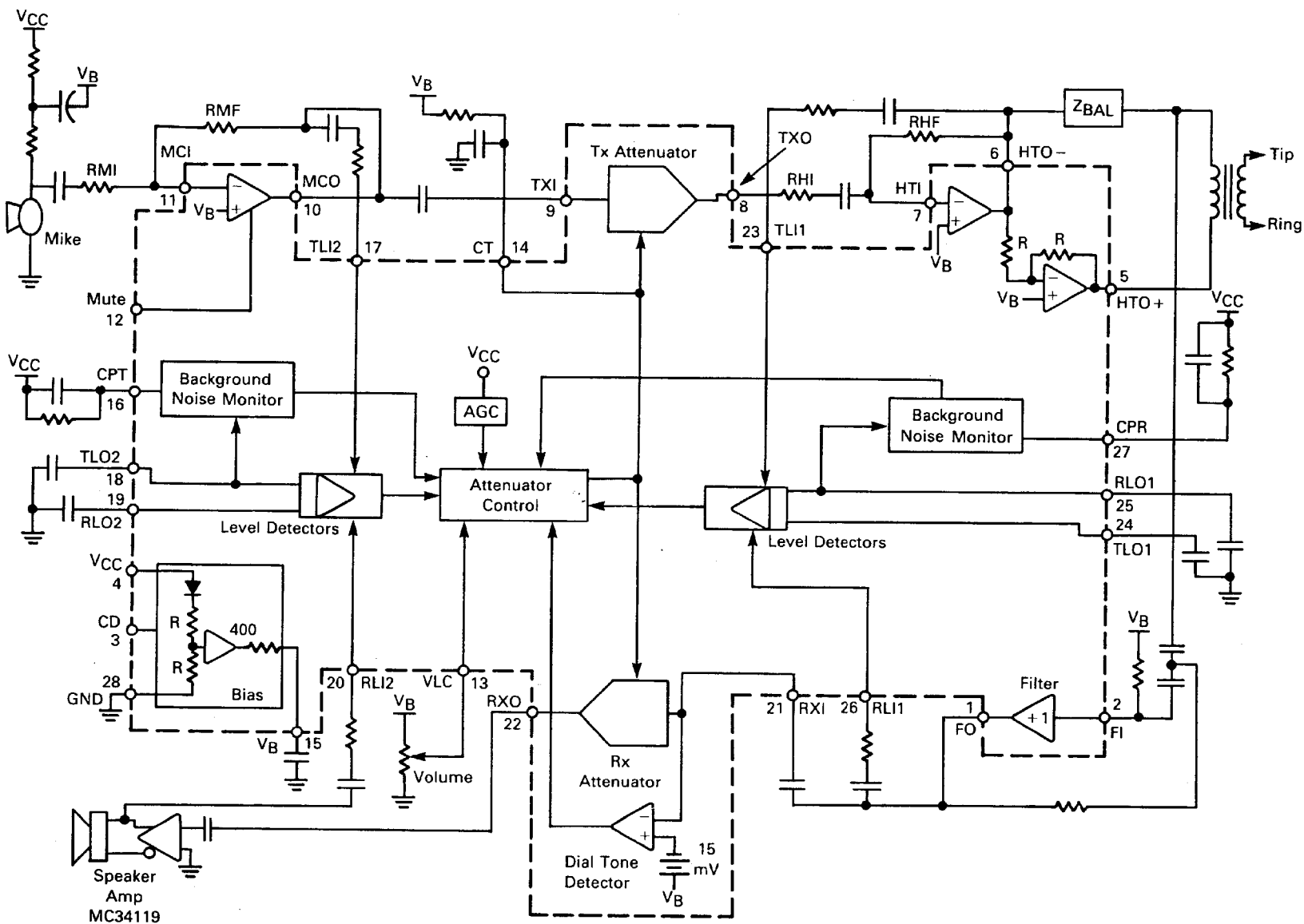

## FUNCTIONAL DESCRIPTION

### INTRODUCTION

The fundamental difference between the operation of a speakerphone and a handset is that of half-duplex versus full-duplex. The handset is full duplex since conversation can occur in both directions (transmit and receive) simultaneously. A speakerphone has higher gain levels in both paths, and attempting to converse full duplex results in oscillatory problems due to the loop that exists within the system. The loop is formed by the receive and transmit paths, the hybrid, and the acoustic coupling (speaker to microphone). The only practical and economical solution used to date is to design the speakerphone to function in a half duplex mode — i.e., only one person speaks at a time, while the other listens. To achieve this requires a circuit which can detect who is talking, switch on the appropriate path (transmit or receive), and switch off (attenuate) the other path. In this way, the loop gain is maintained less than unity. When the talkers exchange function, the circuit must quickly detect this, and switch the circuit appropriately. By providing speech level detectors, the circuit operates in a "hands-free" mode, eliminating the need for a "push-to-talk" switch.

The handset, by the way, has the same loop as the speakerphone. But since the gains are considerably lower, and since the acoustic coupling from the earpiece to the mouthpiece is almost non-existent (the receiver is normally held against a person's ear), oscillations don't occur.

The MC34118 provides the necessary level detectors, attenuators, and switching control for a properly operating speakerphone. The detection sensitivity and timing are externally controllable. Additionally, the MC34118 provides background noise monitors which make the circuit insensitive to room and line noise, hybrid amplifiers for interfacing to Tip and Ring, the microphone amplifier, and other associated functions. Please refer to the Block Diagram (Figure 2) when reading the following sections.

### ATTENUATORS

The transmit and receive attenuators are complementary in function, i.e., when one is at maximum gain (+6.0 dB), the other is at maximum attenuation (-46 dB), and vice versa. They are never both fully on or both fully off. The sum of their gains remains constant (within a nominal error band of  $\pm 0.1$  dB) at a typical value of -40 dB (see Figure 10). Their purpose is to control the transmit and receive paths to provide the half-duplex operation required in a speakerphone.

The attenuators are non-inverting, and have a -3.0 dB (from max gain) frequency of  $\approx 100$  kHz. The input impedance of each attenuator (TXI and RXI) is nominally 10 k $\Omega$  (see Figure 3), and the input signal should be limited to 350 mVrms (990 mVp-p) to prevent distortion. That maximum recommended input signal is independent of the volume control setting. The diode clamp on

the inputs limits the input swing, and therefore the maximum negative output swing. This is the reason for VRXOL and VTXOL specification being defined as they are in the Electrical Characteristics. The output impedance is  $< 10 \Omega$  until the output current limit (typically 2.5 mA) is reached.

FIGURE 3 — ATTENUATOR INPUT STAGE

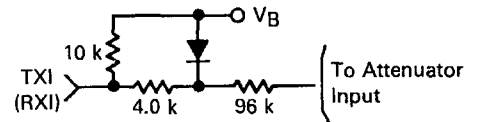

The attenuators are controlled by the single output of the Control Block, which is measurable at the  $C_T$  pin (Pin 14). When the  $C_T$  pin is at +240 millivolts with respect to  $V_B$ , the circuit is in the receive mode (receive attenuator is at +6.0 dB). When the  $C_T$  pin is at -240 millivolts with respect to  $V_B$ , the circuit is in the transmit mode (transmit attenuator is at +6.0 dB). The circuit is in an idle mode when the  $C_T$  voltage is equal to  $V_B$ , causing the attenuators' gains to be halfway between their fully on and fully off positions (-20 dB each). Monitoring the  $C_T$  voltage (with respect to  $V_B$ ) is the most direct method of monitoring the circuit's mode.

The inputs to the Control Block are seven: 2 from the comparators operated by the level detectors, 2 from the background noise monitors, the volume control, the dial-tone detector, and the AGC circuit. These seven inputs are described below.

### LEVEL DETECTORS

There are four level detectors — two on the receive side and two on the transmit side. Refer to Figure 4 — the terms in parentheses form one system, and the other terms form the second system. Each level detector is a high gain amplifier with back-to-back diodes in the feedback path, resulting in non-linear gain, which permits operation over a wide dynamic range of speech levels. Refer to the graphs of Figures 11, 12 and 13 for their dc and ac transfer characteristics. The sensitivity of each level detector is determined by the external resistor and capacitor at each input (TLI1, TLI2, RLI1, and RLI2). Each output charges an external capacitor through a diode and limiting resistor, thus providing a dc representation of the input ac signal level. The outputs have a quick rise time (determined by the capacitor and an internal 350  $\Omega$  resistor), and a slow decay time set by an internal current source and the capacitor. The capacitors on the four outputs should have the same value ( $\pm 10\%$ ) to prevent timing problems.

Referring to Figure 2, on the receive side, one level detector (RLI1) is at the receive input receiving the same

FIGURE 4 — LEVEL DETECTORS

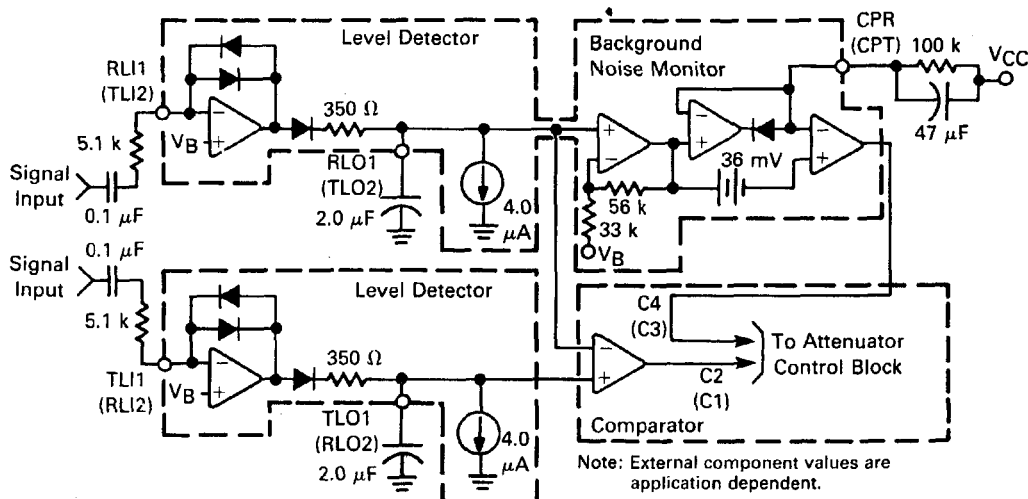

signal as at Tip and Ring, and the other (RLI2) is at the output of the speaker amplifier. On the transmit side, one level detector (TLI2) is at the output of the microphone amplifier, while the other (TLI1) is at the hybrid output. Outputs RLO1 and TLO1 feed a comparator, the output of which goes to the Attenuator Control Block. Likewise, outputs RLO2 and TLO2 feed a second comparator which also goes to the Attenuator Control Block. The truth table for the effects of the level detectors on the Control Block is given in the section describing the Control Block.

**BACKGROUND NOISE MONITORS**

The purpose of the background noise monitors is to distinguish speech (which consists of bursts) from background noise (a relatively constant signal level). There are two background noise monitors — one for the receive path and one for the transmit path. Referring to Figure 4, the receive background noise monitor is operated on by the RLI1-RLO1 level detector, while the transmit background noise monitor is operated on by the TLI2-TLO2 level detector. They monitor the background noise by storing a dc voltage representative of the respective noise levels in capacitors at CPR and CPT. The voltages at these pins have slow rise times (determined by the external RC), but fast decay times. If the signal at RLI1 (or TLI2) changes slowly, the voltage at CPR (or CPT) will remain more positive than the voltage at the non-inverting input of the monitor's output comparator. When speech is present, the voltage on the non-inverting input of the comparator will rise quicker than the voltage at the inverting input (due to the burst characteristic of speech), causing its output to change. This output is sensed by the Attenuator Control Block.

The 36 mV offset at the comparator's input keeps the comparator from changing state unless the speech level

exceeds the background noise by ≈4.0 dB. The time constant of the external RC (≈4.7 seconds) determines the response time to background noise variations.

**VOLUME CONTROL**

The volume control input at VLC (Pin 13) is sensed as a voltage with respect to V<sub>B</sub>. The volume control affects the attenuators *only* in the receive mode. It has no effect in the idle or transmit modes.

When in the receive mode, the gain of the receive attenuator will be +6.0 dB, and the gain of the transmit attenuator will be -46 dB only when VLC is equal to V<sub>B</sub>. As VLC is reduced below V<sub>B</sub>, the gain of the receive attenuator is reduced (see Figure 14), and the gain of the transmit attenuator is increased such that their sum remains constant. Changing the voltage at VLC changes the voltage at C<sub>T</sub> (see the Attenuator Control Block section), which in turn controls the attenuators.

The volume control setting does not affect the maximum attenuator input signal at which noticeable distortion occurs.

The bias current at VLC is typically 60 nA out of the pin, and does not vary significantly with the VLC voltage or with VCC.

**DIAL TONE DETECTOR**

The dial tone detector is a comparator with one side connected to the receive input (RXI) and the other input connected to V<sub>B</sub> with a 15 mV offset (see Figure 5). If the circuit is in the receive mode, and the incoming signal is greater than 15 mV (10 mVrms), the comparator's output will change, disabling the receive idle mode. The receive attenuator will then be at a setting determined solely by the volume control.

The purpose of this circuit is to prevent the dial tone



(which would be considered as continuous noise) from fading away as the circuit would have the tendency to switch to the idle mode. By disabling the receive idle mode, the dial tone remains at the normally expected full level.

FIGURE 5 — DIAL TONE DETECTOR

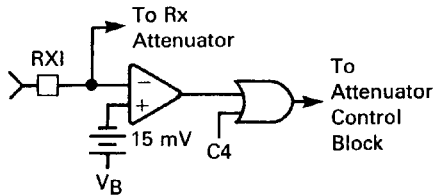

### AGC

The AGC circuit affects the circuit only in the receive mode, and only when the supply voltage ( $V_{CC}$ ) is less than 3.5 volts. As  $V_{CC}$  falls below 3.5 volts, the gain of the receive attenuator is reduced according to the graph of Figure 15. The transmit path attenuation changes such that the sum of the transmit and receive gains remains constant.

The purpose of this feature is to reduce the power (and current) used by the speaker when a line-powered speakerphone is connected to a long line, where the available power is limited. By reducing the speaker power, the voltage sag at  $V_{CC}$  is controlled, preventing possible erratic operation.

### ATTENUATOR CONTROL BLOCK

The Attenuator Control Block has the seven inputs described above:

- The output of the comparator operated by RLO2 and TLO2 (microphone/speaker side) — designated C1.
- The output of the comparator operated by RLO1 and TLO1 (Tip/Ring side) — designated C2.
- The output of the transmit background noise monitor — designated C3.
- The output of the receive background noise monitor — designated C4.
- The volume control.
- The dial tone detector.
- The AGC circuit.

The single output of the Control Block controls the two attenuators. The effect of C1–C4 is as follows:

C1	Inputs			Output Mode
	C2	C3	C4	
Tx	Tx	1	X	Transmit
Tx	Rx	y	y	Fast Idle
Rx	Tx	y	y	Fast Idle
Rx	Rx	X	1	Receive
Tx	Tx	0	X	Slow Idle
Tx	Rx	0	0	Slow Idle
Rx	Tx	0	0	Slow Idle
Rx	Rx	X	0	Slow Idle

X = Don't Care; y = C3 and C4 are not both 0.

A definition of the above terms:

- 1) "Transmit" means the transmit attenuator is fully on (+6.0 dB), and the receive attenuator is at max. attenuation (-46 dB).
- 2) "Receive" means both attenuators are controlled by the volume control. At max. volume, the receive attenuator is fully on (+6.0 dB), and the transmit attenuator is at max. attenuation (-46 dB).
- 3) "Fast Idle" means both transmit and receive speech are present in approximately equal levels. The attenuators are quickly switched (30 ms) to idle until one speech level dominates the other.
- 4) "Slow Idle" means speech has ceased in both transmit and receive paths. The attenuators are then slowly switched (1 second) to the idle mode.
- 5) Switching to the full transmit or receive modes from any other mode is at the fast rate ( $\approx 30$  ms).

A summary of the truth table is as follows:

1) The circuit will switch to transmit if: a) *both* transmit level detectors sense higher signal levels relative to the respective receive level detectors (TLI1 versus RLI1, TLI2 versus RLI2), *and* b) the transmit background noise monitor indicates the presence of speech.

2) The circuit will switch to receive if: a) *both* receive level detectors sense higher signal levels relative to the respective transmit level detectors, *and* b) the receive background noise monitor indicates the presence of speech.

3) The circuit will switch to the fast idle mode if the level detectors *disagree* on the relative strengths of the signal levels, *and* at least one of the background noise monitors indicates speech. For example, referring to the Block Diagram (Figure 2), if there is sufficient signal at the microphone amp output (TLI2) to override the speaker signal (RLI2), *and* there is sufficient signal at the receive input (RLI1) to override the signal at the hybrid output (TLI1), *and* either or both background monitors indicate speech, then the circuit will be in the fast idle mode. Two conditions which can cause the fast idle mode to occur are a) when both talkers are attempting to gain control of the system by talking at the same time, and b) when one talker is in a very noisy environment, forcing the other talker to continually override that noise level. In general, the fast idle mode will occur infrequently.

4) The circuit will switch to the slow idle mode when a) both talkers are quiet (no speech present), or b) when one talker's speech level is continuously overridden by noise at the other speaker's location.

The time required to switch the circuit between transmit, receive, fast idle and slow idle is determined in part by the components at the  $C_T$  pin (Pin 14). (See the section on Switching Times for a more complete explanation of the switching time components.) A schematic of the  $C_T$  circuitry is shown in Figure 6, and operates as follows:

- $R_T$  is typically 120 k $\Omega$ , and  $C_T$  is typically 5.0  $\mu$ F.
- To switch to the receive mode,  $I_1$  is turned on ( $I_2$  is off), charging the external capacitor to +240 mV above  $V_B$ . (An internal clamp prevents further charging of the capacitor.)
- To switch to the transmit mode,  $I_2$  is turned on ( $I_1$  is off) bringing down the voltage on the capacitor to -240 mV with respect to  $V_B$ .

- To switch to idle quickly (fast idle), the current sources are turned off, and the internal 2.0 kΩ resistor is switched in, discharging the capacitor to  $V_B$  with a time constant  $= 2.0 \text{ k} \times C_T$ .
- To switch to idle slowly (slow idle), the current sources are turned off, the switch at the 2.0 kΩ resistor is open, and the capacitor discharges to  $V_B$  through the external resistor  $R_T$  with a time constant  $= R_T \times C_T$ .

FIGURE 6 — CT ATTENUATOR CONTROL BLOCK CIRCUIT

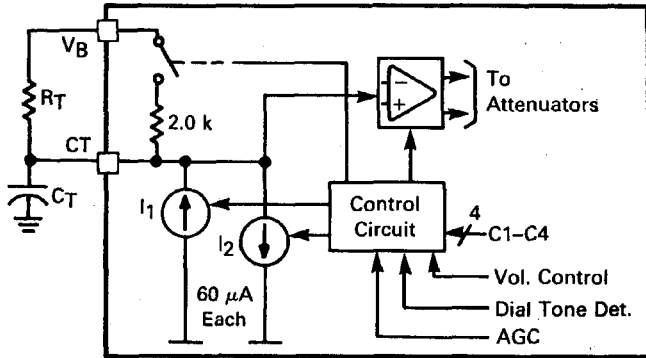

**MICROPHONE AMPLIFIER**

The microphone amplifier (Pins 10, 11) has the non-inverting input internally connected to  $V_B$ , while the inverting input and the output are pinned out. Unlike most op-amps, the amplifier has an all-NPN output stage, which maximizes phase margin and gain-bandwidth. This feature ensures stability at gains less than unity, as well as with a wide range of reactive loads. The open loop gain is typically 80 dB ( $f < 100 \text{ Hz}$ ), and the gain-bandwidth is typically 1.0 MHz (See Figure 16). The maximum p-p output swing is typically 1.0 volt less than  $V_{CC}$  with an output impedance of  $< 10 \Omega$  until current limiting is reached (typically 1.5 mA). Input bias current at MCI is typically 40 nA out of the pin.

FIGURE 7 — MICROPHONE AMPLIFIER AND MUTE

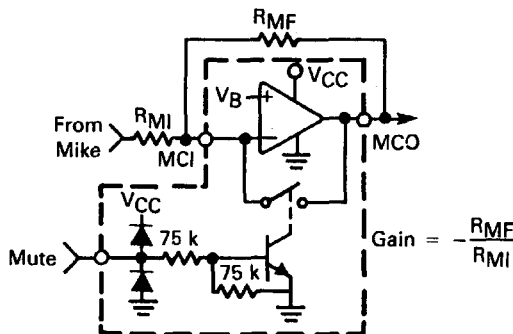

The muting function (Pin 12), when activated, will reduce the gain of the amplifier to  $\approx -39 \text{ dB}$  (with  $R_{MI} = 5.1 \text{ k}\Omega$ ) by shorting the output to the inverting input (see Figure 7). The mute input has a threshold of  $\approx 1.5$

volts, and the voltage at this pin must be kept within the range of ground and  $V_{CC}$  (see Figure 17). If the mute function is not used, the pin should be grounded.

**HYBRID AMPLIFIERS**

The two hybrid amplifiers (at HTO +, HTO -, and HTI), in conjunction with an external transformer, provide the two-to-four wire converter for interfacing to the telephone line. The gain of the first amplifier (HTI to HTO -) is set by external resistors (gain  $= -R_{HF}/R_{HI}$  in Figure 2), and its output drives the second amplifier, the gain of which is internally set at  $-1.0$ . Unlike most op-amps, the amplifiers have an all-NPN output stage, which maximizes phase margin and gain-bandwidth. This feature ensures stability at gains less than unity, as well as with a wide range of reactive loads. The open loop gain of the first amplifier is typically 80 dB, and the gain bandwidth of each amplifier is  $\approx 1.0 \text{ MHz}$  (see Figure 16). The maximum p-p output swing of each amplifier is typically 1.2 volts less than  $V_{CC}$  with an output impedance of  $< 10 \Omega$  until current limiting is reached (typically 8.0 mA). The output current capability is guaranteed to be a minimum of 5.0 mA. The bias current at HTI is typically 30 nA out of the pin.

The connections to the coupling transformer are shown in the Block Diagram (Figure 2). The block labeled ZBal is the balancing network necessary to match the line impedance.

**FILTER**

The operation of the filter circuit is determined by the external components. The circuit within the MC34118, from pins FI to FO is a buffer with a high input impedance ( $> 1.0 \text{ M}\Omega$ ), and a low output impedance ( $< 50 \Omega$ ). The configuration of the external components determines whether the circuit is a high-pass filter (as shown in Figure 2), a low-pass filter, or a band-pass filter.

As a high pass filter, with the components shown in Figure 8, the filter will keep out 60 Hz (and 120 Hz) hum which can be picked up by the external telephone lines.

FIGURE 8 — HIGH PASS FILTER

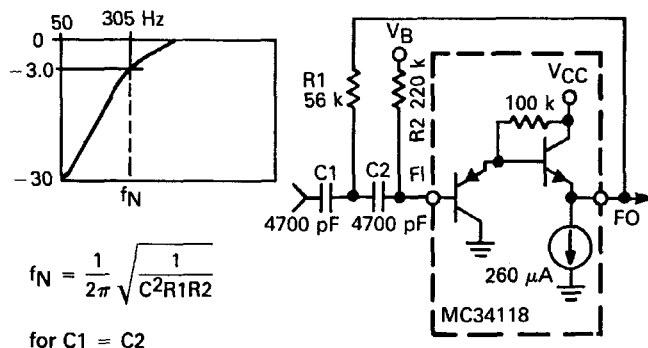

As a low pass filter (Figure 9), it can be used to roll off the high end frequencies in the receive circuit, which aids in protecting against acoustic feedback problems.

With an appropriate choice of an input coupling capacitor to the low pass filter, a band pass filter is formed.

FIGURE 9 — LOW PASS FILTER

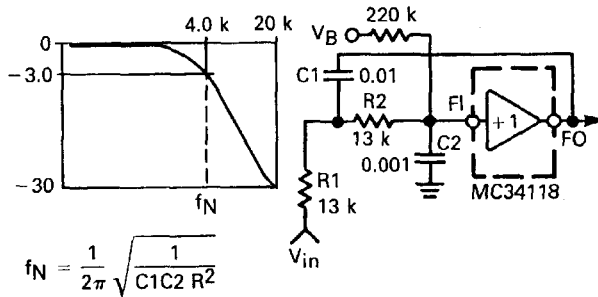

$$f_N = \frac{1}{2\pi \sqrt{C1C2 R^2}}$$

for  $R1 = R2$

### POWER SUPPLY, $V_B$ , AND CHIP DISABLE

The power supply voltage at  $V_{CC}$  (Pin 4) is to be between 3.5 and 6.5 volts for normal operation, with reduced operation possible down to 2.8 volts (see Figure 15 and the AGC section). The power supply current is shown in Figure 18 for both the power-up and power-down mode.

FIGURE 10 — ATTENUATOR GAIN versus  $V_{CT}$  (PIN 14)

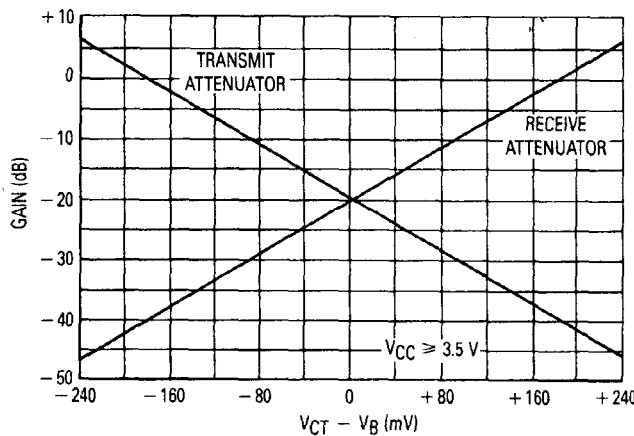
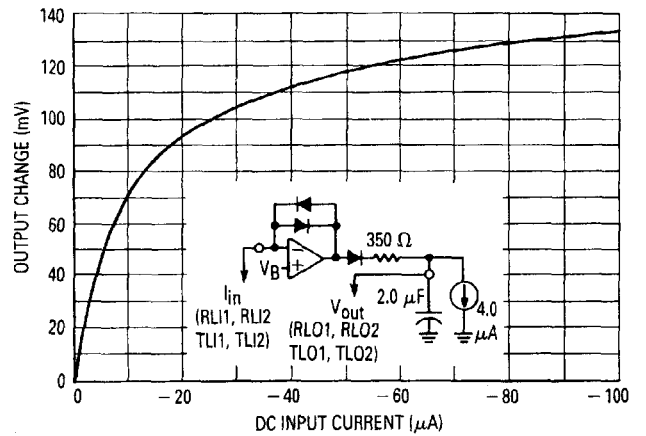

FIGURE 11 — LEVEL DETECTOR DC TRANSFER CHARACTERISTICS



The output voltage at  $V_B$  (Pin 15) is  $\approx (V_{CC} - 0.7)/2$ , and provides the ac ground for the system. The output impedance at  $V_B$  is  $\approx 400 \Omega$  (see Figure 19), and in conjunction with the external capacitor at  $V_B$ , forms a low pass filter for power supply rejection. Figure 20 indicates the amount of rejection with different capacitors. The choice of capacitor is application dependent based on whether the circuit is powered by the telephone line or a power supply.

Since  $V_B$  biases the microphone and hybrid amplifiers, the amount of supply rejection at their outputs is directly related to the rejection at  $V_B$ , as well as their respective gains. Figure 21 depicts this graphically.

The Chip Disable (Pin 3) permits powering down the IC to conserve power and/or for muting purposes. With  $CD \leq 0.8$  volts, normal operation is in effect. With  $CD \geq 2.0$  volts and  $\leq V_{CC}$ , the IC is powered down. In the powered down mode, the microphone and the hybrid amplifiers are disabled, and their outputs go to a high impedance state. Additionally, the bias is removed from the level detectors. The bias is not removed from the filter (Pins 1, 2), the attenuators (Pins 8, 9, 21, 22), or from Pins 13, 14, and 15 (the attenuators are disabled, however, and will not pass a signal). The input impedance at CD is typically 90 k $\Omega$ , has a threshold of  $\approx 1.5$  volts, and the voltage at this pin must be kept within the range of ground and  $V_{CC}$  (see Figure 17). If CD is not used, the pin should be grounded.

FIGURE 12 — LEVEL DETECTOR AC TRANSFER CHARACTERISTICS

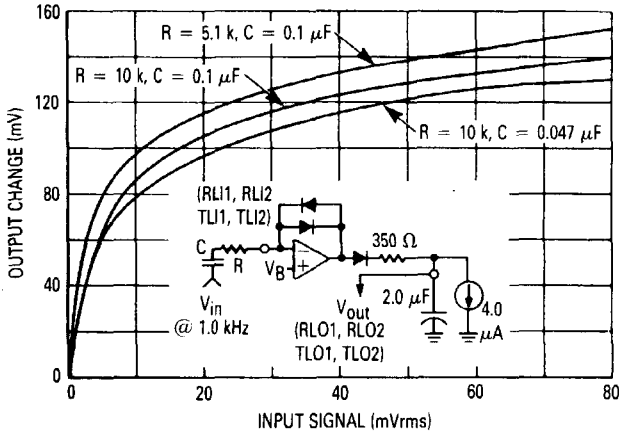

FIGURE 13 — LEVEL DETECTOR AC TRANSFER CHARACTERISTICS versus FREQUENCY

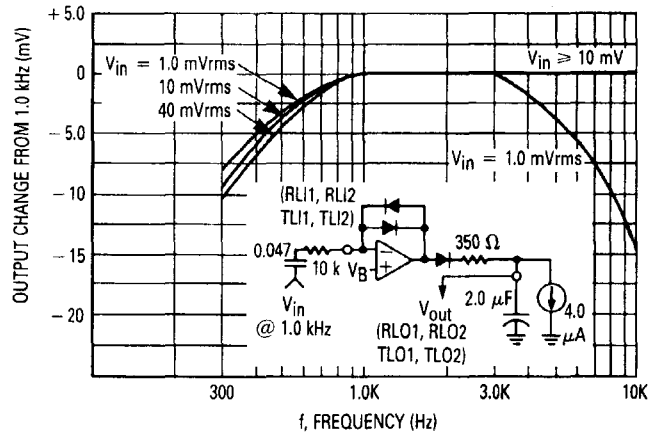

FIGURE 14 — RECEIVE ATTENUATOR versus VOLUME CONTROL

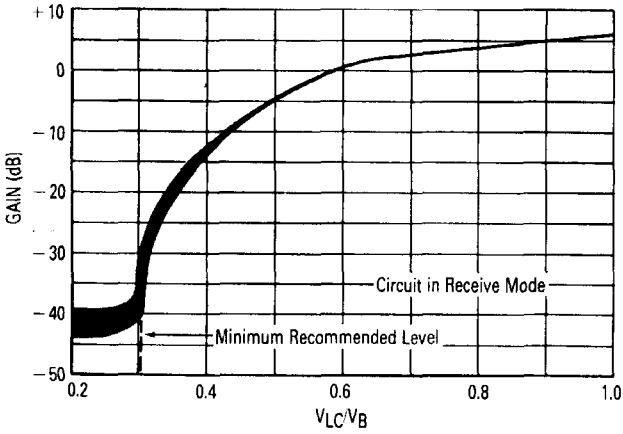

FIGURE 15 — RECEIVE ATTENUATION GAIN versus V<sub>CC</sub>

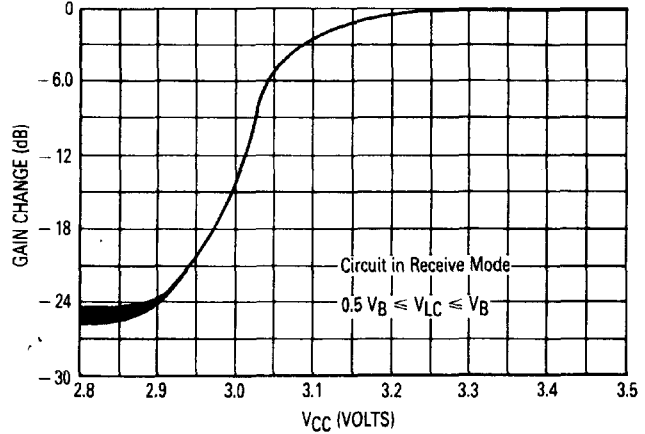

FIGURE 16 — MICROPHONE AMPLIFIER AND 1ST HYBRID AMPLIFIER OPEN LOOP GAIN AND PHASE

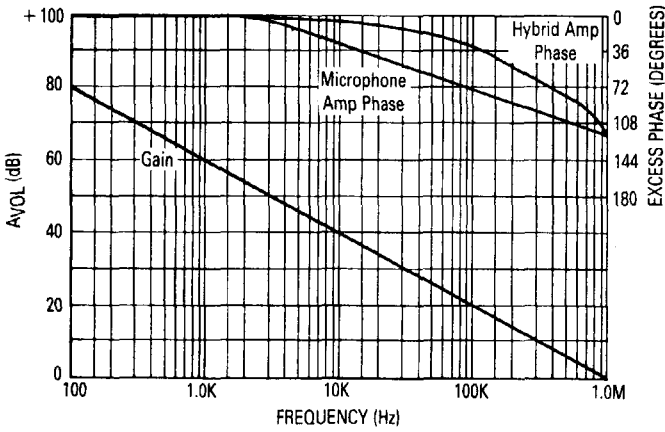

FIGURE 17 — INPUT CHARACTERISTICS @ CD, MUT

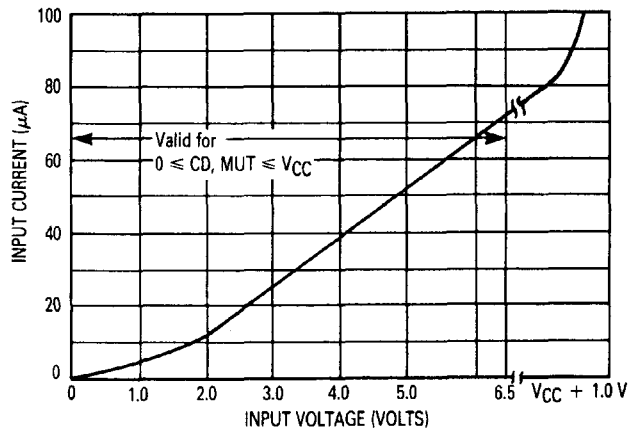

FIGURE 18 — SUPPLY CURRENT versus SUPPLY VOLTAGE

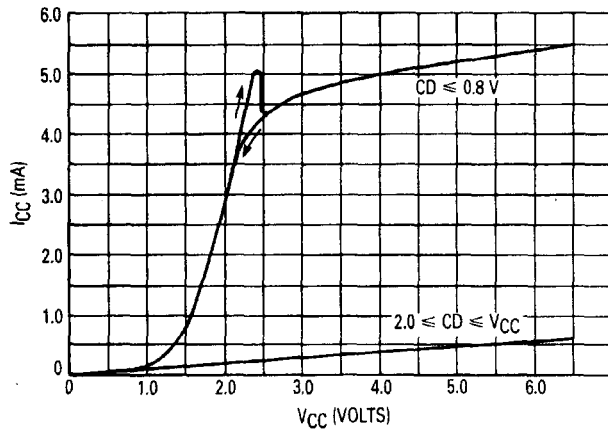

FIGURE 19 —  $V_B$  OUTPUT CHARACTERISTICS

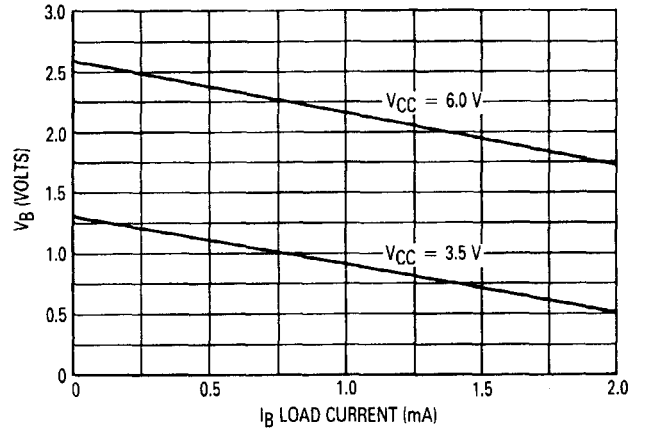

FIGURE 20 —  $V_B$  POWER SUPPLY REJECTION versus FREQUENCY AND  $V_B$  CAPACITOR

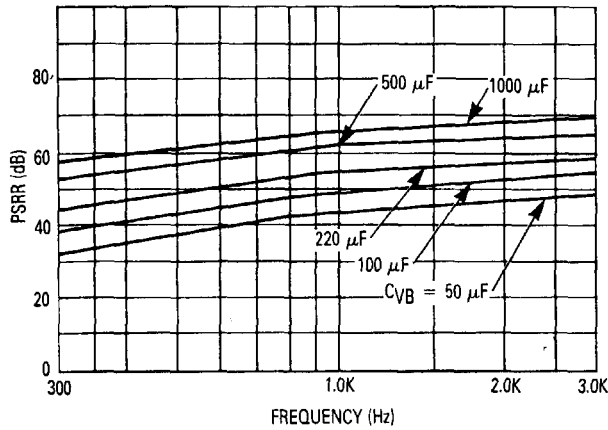

FIGURE 21 — POWER SUPPLY REJECTION OF THE MICROPHONE AND HYBRID AMPLIFIERS

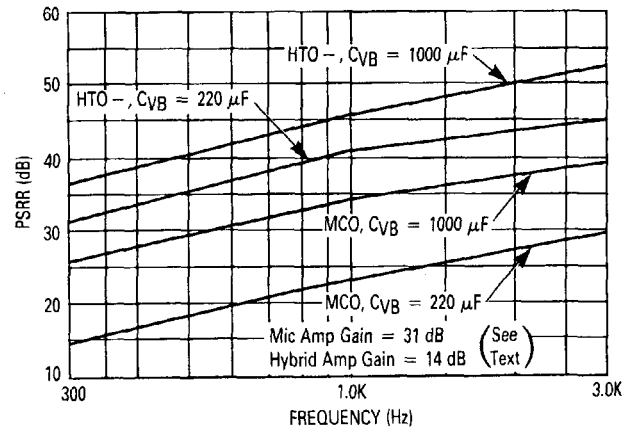
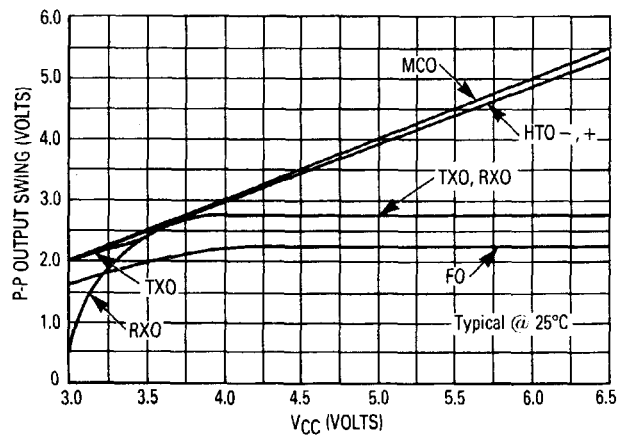

FIGURE 22 — TYPICAL OUTPUT SWING versus  $V_{CC}$



## DESIGN GUIDELINES

### SWITCHING TIME

The switching time of the MC34118 circuit is dominated by the components at  $C_T$  (Pin 14, refer to Figure 6), and secondarily by the capacitors at the level detector outputs (RLO1, RLO2, TLO1, TLO2).

The time to switch to receive or to transmit from idle is determined by the capacitor at  $C_T$ , together with the internal current sources (refer to Figure 6). The switching time is:

$$\Delta T = \frac{\Delta V \times C_T}{I}$$

For the typical case where  $\Delta V = 240$  mV,  $I = 60$   $\mu$ A, and  $C_T$  is  $5.0$   $\mu$ F,  $\Delta T = 20$  ms. If the circuit switches directly from receive to transmit (or vice-versa), the total switching time would be 40 ms.

The switching time from either receive or transmit to idle depends on which type of idle mode is in effect. If the circuit is going to "fast idle," the time constant is determined by the  $C_T$  capacitor, and the internal  $2.0$  k $\Omega$  resistor (Figure 6). With  $C_T = 5.0$   $\mu$ F, the time constant is  $\approx 10$  ms, giving a switching time to idle of  $\approx 30$  ms (for 95% change). Fast idle is an infrequent occurrence, however, occurring when both speakers are talking and competing for control of the circuit. The switching time from idle back to either transmit or receive is described above.

If the circuit is switching to "slow idle," the time constant is determined by the  $C_T$  capacitor and  $R_T$ , the external resistor (see Figure 6). With  $C_T = 5.0$   $\mu$ F, and  $R_T = 120$  k $\Omega$ , the time constant is  $\approx 600$  ms, giving a switching time of  $\approx 1.8$  seconds (for 95% change). The switching period to slow idle begins when both speakers have stopped talking. The switching time back to the original mode will depend on how soon that speaker begins speaking again. The sooner the speaking starts during the 1.8 second period, the quicker the switching time since a smaller voltage excursion is required. That switching time is determined by the internal current sources as described above.

The above switching times occur, however, after the level detectors have detected the appropriate signal levels, since their outputs operate the Attenuator Control Block. Referring to Figure 4, the rise time of the level detectors' outputs to new speech is quick by comparison ( $\approx 1.0$  ms), determined by the internal  $350$   $\Omega$  resistor and the external capacitor (typically  $2.0$   $\mu$ F). The output's decay time is determined by the external capacitor, and an internal  $4.0$   $\mu$ A current source giving a decay rate of  $\approx 60$  ms for a  $120$  mV excursion at RLO or TLO. However, the overall response time of the circuit is not a constant since it depends on the relative strength of the signals at the different level detectors, as well as the timing of the signals with respect to each other. The capacitors at the four outputs (RLO1, RLO2, TLO1, TLO2) must be equal value ( $\pm 10\%$ ) to prevent problems in timing and level response.

The rise time of the level detector's outputs is not significant since it is so short. The decay time, however, provides a significant part of the "hold time" necessary to hold the circuit during the normal pauses in speech.

The components at the inputs of the level detectors (RLI1, RLI2, TLI1, TLI2) do not affect the switching time, but rather affect the relative signal levels required to switch the circuit, as well as the frequency response of the detectors.

### DESIGN EQUATIONS

Referring to Figure 24 (the coupling capacitors have been omitted for simplicity), and the circuit of Figure 23, the following definitions will be used (all measurements are at 1.0 kHz):

- $G_{MA}$  is the gain of the microphone amplifier measured from the microphone output to TXI (typically 35 V/V, or 31 dB);
- $G_{TX}$  is the gain of the transmit attenuator, measured from TXI to TXO;
- $G_{HA}$  is the gain of hybrid amplifiers, measured from TXO to the HTO -/HTO + differential output (typically 10.2 V/V, or 20.1 dB);
- $G_{HT}$  is the gain from HTO -/HTO + to Tip/Ring for transmit signals, and includes the balance network (measured at 0.4 V/V, or -8.0 dB);
- $G_{ST}$  is the sidetone gain, measured from HTO -/HTO + to the filter input (measured at 0.18 V/V, or -15 dB);
- $G_{HR}$  is the gain from Tip/Ring to the filter input for receive signals (measured at 0.833 V/V or -1.6 dB);
- $G_{FO}$  is the gain of the filter stage, measured from the input of the filter to RXI, typically 0 dB at 1.0 kHz;
- $G_{RX}$  is the gain of the receive attenuator measured from RXI to RXO;
- $G_{SA}$  is the gain of the speaker amplifier, measured from RXO to the differential output of the MC34119 (typically 22 V/V or 26.8 dB);
- $G_{AC}$  is the acoustic coupling, measured from the speaker differential voltage to the microphone output voltage.

#### 1) Transmit Gain

The transmit gain, from the microphone output ( $V_M$ ) to Tip and Ring, is determined by the output characteristics of the microphone, and the desired transmit level. For example, a typical electret microphone will produce  $\approx 0.35$  mVrms under normal speech conditions. To achieve 100 mVrms at Tip/Ring, an overall gain of 285 V/V is necessary. The gain of the transmit attenuator is fixed at 2.0 (+6.0 dB), and the gain through the hybrid of Figure 23 ( $G_{HT}$ ) is nominally 0.4 (-8.0 dB). Therefore a gain of 357 V/V is required of the microphone and hybrid amplifiers. It is desirable to have the majority of that gain in the microphone amplifier for three reasons: 1) the low level signals from the microphone should be amplified as soon as possible to minimize signal/noise

FIGURE 23 — MC34118 APPLICATION CIRCUIT  
(BASIC LINE POWERED SPEAKERPHONE)

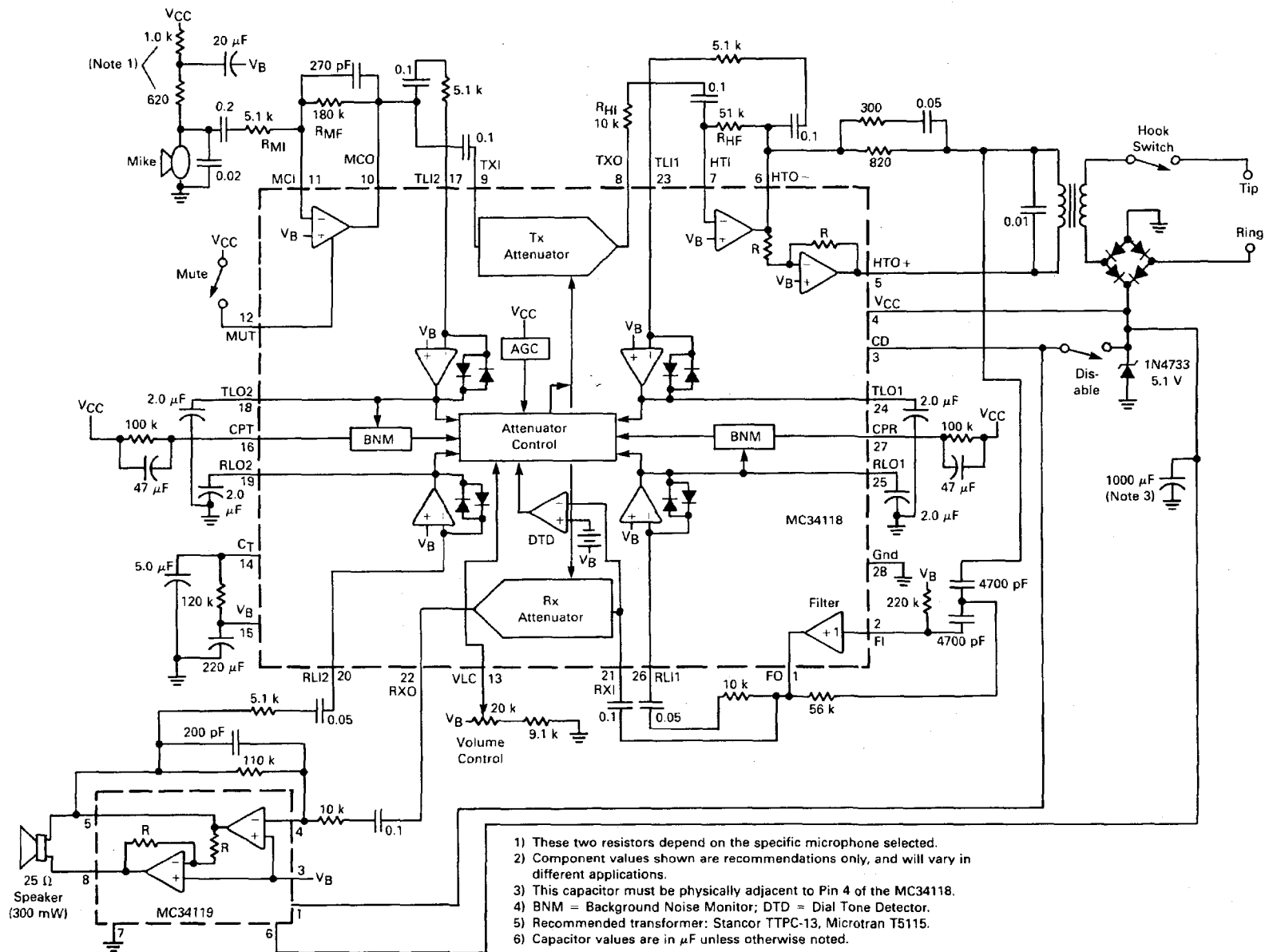

- 1) These two resistors depend on the specific microphone selected.
- 2) Component values shown are recommendations only, and will vary in different applications.
- 3) This capacitor must be physically adjacent to Pin 4 of the MC34118.
- 4) BNM = Background Noise Monitor; DTD = Dial Tone Detector.
- 5) Recommended transformer: Stancor TTPC-13, Microtran T5115.
- 6) Capacitor values are in  $\mu\text{F}$  unless otherwise noted.

FIGURE 24 — BASIC BLOCK DIAGRAM FOR DESIGN PURPOSES

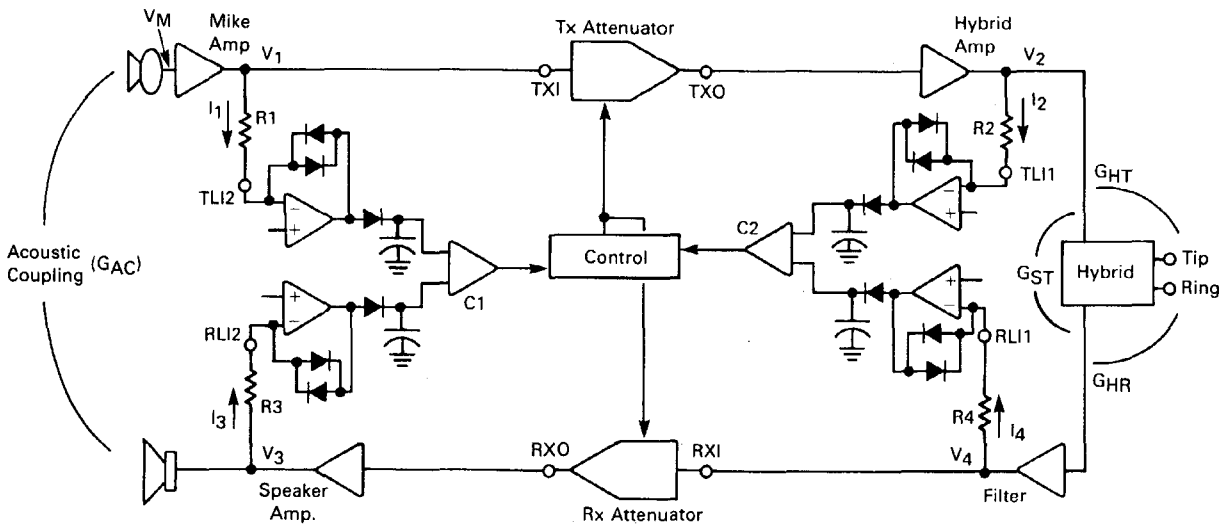

problems; 2) to provide a reasonable signal level to the TL12 level detector; and 3) to minimize any gain applied to broadband noise generated within the attenuator. However, to cover the normal voiceband, the microphone amplifier's gain should not exceed 48 dB (see Figure 16). For the circuit of Figure 23, the gain of the microphone amplifier was set at 35 V/V (31 dB), and the differential gain of the hybrid amplifiers was set at 10.2 V/V (20.1 dB).

### II) Receive Gain

The overall receive gain depends on the incoming signal level, and the desired output power at the speaker. Nominal receive levels (independent of the peaks) at Tip/Ring can be 35 mVrms (-27 dBm), although on long lines that level can be down to 8.0 mVrms (-40 dBm). The speaker power is:

$$P_{SPK} = \frac{10\text{dBm}/10 \times 0.6}{R_S} \quad (\text{Equation 1})$$

where  $R_S$  is the speaker impedance, and the dBm term is the incoming signal level increased by the gain of the receive path. Experience has shown that  $\approx 30$  dB gain is a satisfactory amount for the majority of applications. Using the above numbers and Equation 1, it would appear that the resulting power to the speaker is extremely low. However, Equation 1 does not consider the peaks in normal speech, which can be 10 to 15 times the rms value. Considering the peaks, the overall average power approaches 20–30 mW on long lines, and much more on short lines.

Referring to Figure 23, the gain from Tip/Ring to the filter input was measured at 0.833 V/V (-1.6 dB), the

filter's gain is unity, and the receive attenuator's gain is 2.0 V/V (+6.0 dB) at maximum volume. The speaker amplifier's gain is set at 22 V/V (26.8 dB), which puts the overall gain at  $\approx 31.2$  dB.

### III) Loop Gain

The total loop gain (of Figure 24) must add up to less than zero dB to obtain a stable circuit. This can be expressed as:

$$G_{MA} + G_{TX} + G_{HA} + G_{ST} + G_{FO} + G_{RX} + G_{SA} + G_{AC} < 0 \quad (\text{Equation 2})$$

Using the typical numbers mentioned above, and knowing that  $G_{TX} + G_{RX} = -40$  dB, the required acoustic coupling can be determined:

$$G_{AC} < -[31 + 20.1 + (-15) + 0 + (-40) + 26.8] = -22.9 \text{ dB} \quad (\text{Equation 3})$$

An acoustic loss of at least 23 dB is necessary to prevent instability and oscillations, commonly referred to as "singing." However, the following equations show that greater acoustic loss is necessary to obtain proper level detection and switching.

### IV) Switching Thresholds

To switch comparator C1, currents  $I_1$  and  $I_3$  need to be determined. Referring to Figure 24, with a receive signal  $V_L$  applied to Tip/Ring, a current  $I_3$  will flow through R3 into RLI2 according to the following equation:

$$I_3 = \frac{V_L}{R_3} \left[ G_{HR} \times G_{FO} \times G_{RX} \times \frac{G_{SA}}{2} \right] \quad (\text{Equation 4})$$



where the terms in the brackets are the V/V gain terms. The speaker amplifier gain is divided by two since  $G_{SA}$  is the differential gain of the amplifier, and  $V_3$  is obtained from one side of that output. The current  $I_1$ , coming from the microphone circuit, is defined by:

$$I_1 = \frac{V_M \times G_{MA}}{R_1} \quad (\text{Equation 5})$$

where  $V_M$  is the microphone voltage. Since the switching threshold occurs when  $I_1 = I_3$ , combining the above two equations yields:

$$V_M = V_L \times \frac{R_1 [G_{HR} \times G_{FO} \times G_{RX} \times G_{SA}]}{R_3 \times G_{MA} \times 2} \quad (\text{Equation 6})$$

This is the general equation defining the microphone voltage necessary to switch comparator C1 when a receive signal  $V_L$  is present. The highest  $V_M$  occurs when the receive attenuator is at maximum gain (+6.0 dB). Using the typical numbers for Equation 6 yields:

$$V_M = 0.52 V_L \quad (\text{Equation 7})$$

To switch comparator C2, currents  $I_2$  and  $I_4$  need to be determined. With sound applied to the microphone, a voltage  $V_M$  is created by the microphone, resulting in a current  $I_2$  into TL11:

$$I_2 = \frac{V_M}{R_2} \left[ G_{MA} \times G_{TX} \times \frac{G_{HA}}{2} \right] \quad (\text{Equation 8})$$

Since  $G_{HA}$  is the differential gain of the hybrid amplifiers, it is divided by two to obtain the voltage  $V_2$  applied to R2. Comparator C2 switches when  $I_4 = I_2$ .  $I_4$  is defined by:

$$I_4 = \frac{V_L}{R_4} [G_{HR} \times G_{FO}] \quad (\text{Equation 9})$$

Setting  $I_4 = I_2$ , and combining the above equations results in:

$$V_L = V_M \times \frac{R_4}{R_2} \times \frac{[G_{MA} \times G_{TX} \times G_{HA}]}{[G_{HR} \times G_{FO} \times 2]} \quad (\text{Equation 10})$$

This equation defines the line voltage at Tip/Ring necessary to switch comparator C2 in the presence of a microphone voltage. The highest  $V_L$  occurs when the circuit is in the transmit mode ( $G_{TX} = +6.0$  dB). Using the typical numbers for Equation 10 yields:

$$V_L = 840 V_M \quad (\text{or } V_M = 0.0019 V_L) \quad (\text{Equation 11})$$

At idle, where the gain of the two attenuators is -20 dB (0.1 V/V), Equations 6 and 10 yield the same result:

$$V_M = 0.024 V_L \quad (\text{Equation 12})$$

Equations 7, 11, and 12 define the thresholds for switching, and are represented in the following graph:

FIGURE 25 — SWITCHING THRESHOLDS

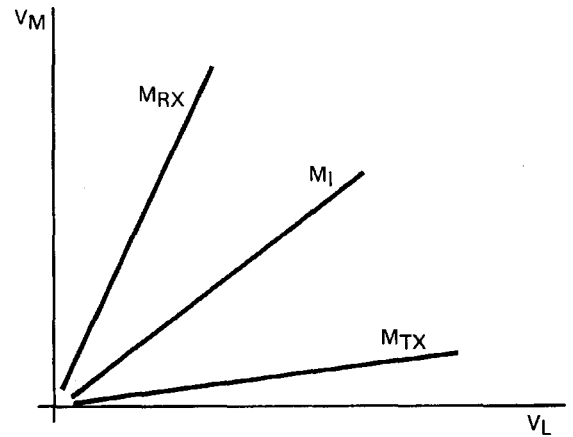

The "M" terms are the slopes of the lines (0.52, 0.024, and 0.0019) which are the coefficients of the three equations. The MRX line represents the receive to transmit threshold in that it defines the microphone signal level necessary to switch to transmit in the presence of a given receive signal level. The MTX line represents the transmit to receive threshold. The MI line represents the idle condition, and defines the threshold level on one side (transmit or receive) necessary to overcome noise on the other.

Some comments on the above graph:

— Acoustic coupling and sidetone coupling were not included in Equations 7 and 12. Those couplings will affect the actual performance of the final speakerphone due to their interaction with speech at the microphone, and the receive signal coming in at Tip/Ring. The effects of those couplings are difficult to predict due to their associated phase shifts and frequency response. In some cases the coupling signal will add, and other times subtract from the incoming signal. The physical design of the speakerphone enclosure, as well as the specific phone line to which it is connected, will affect the acoustic and sidetone couplings, respectively.

— The MRX line helps define the maximum acoustic coupling allowed in a system, which can be found from the following equation:

$$G_{AC-MAX} = \frac{R_1}{2 \times R_3 \times G_{MA}} \quad (\text{Equation 13})$$

Equation 13 is independent of the volume control setting. Conversely, the acoustic coupling of a designed system helps determine the minimum slope of that line. Using the component values of Figure 23 in Equation

13 yields a GAC-MAX of -37 dB. Experience has shown, however, that an acoustic coupling loss of >40 dB is desirable.

— The M<sub>TX</sub> line helps define the maximum sidetone coupling (G<sub>ST</sub>) allowed in the system, which can be found from the following equation:

$$G_{ST} = \frac{R_4}{2 \times R_2 \times G_{FO}} \quad (\text{Equation 14})$$

Using the component values of Figure 23 in Equation 14 yields a maximum sidetone of 0 dB. Experience has shown, however, that a minimum of 6.0 dB loss is preferable.

The above equations can be used to determine the resistor values for the level detector inputs. Equation 6 can be used to determine the R<sub>1</sub>/R<sub>3</sub> ratio, and Equation 10 can be used to determine the R<sub>4</sub>/R<sub>2</sub> ratio. In Figure 24, R<sub>1</sub>–R<sub>4</sub> each represent the combined impedance of the resistor and coupling capacitor at each level detector input. The magnitude of each RC's impedance should be kept within the range of 2.0 k–15 kΩ in the voiceband (due to the typical signal levels present) to obtain the best performance from the level detectors. The specific R and C at each location will determine the frequency response of that level detector.

## APPLICATION INFORMATION

### DIAL TONE DETECTOR

The threshold for the dial tone detector is internally set at 15 mV (10 mV<sub>rms</sub>) below V<sub>B</sub> (see Figure 5). That threshold can be reduced by connecting a resistor from RX<sub>I</sub> to ground. The resistor value is calculated from:

$$R = 10 \text{ k} \left[ \frac{V_B}{\Delta V} - 1 \right]$$

where V<sub>B</sub> is the voltage at Pin 15, and ΔV is the amount of threshold reduction. By connecting a resistor from V<sub>CC</sub> to RX<sub>I</sub>, the threshold can be increased. The resistor value is calculated from:

$$R = 10 \text{ k} \left[ \frac{V_{CC} - V_B}{\Delta V} - 1 \right]$$

where ΔV is the amount of the threshold increase.

### BACKGROUND NOISE MONITORS

For testing or circuit analysis purposes, the transmit or receive attenuators can be set to the "on" position, by disabling the background noise monitors, and applying a signal so as to activate the level detectors. Grounding the CPR pin will disable the receive background noise monitor, thereby indicating the "presence of speech" to the attenuator control block. Grounding CPT does the same for the transmit path.

Additionally, the receive background noise monitor is automatically disabled by the dial tone detector whenever the receive signal exceeds the detector's threshold.

### TRANSMIT/RECEIVE DETECTION PRIORITY

Although the MC34118 was designed to have an idle mode such that the attenuators are halfway between

their full on and full off positions, the idle mode can be biased towards the transmit or the receive side. With this done, gaining control of the circuit from idle will be easier for that side towards which it is biased since that path will have less attenuation at idle.

By connecting a resistor from C<sub>T</sub> (Pin 14) to ground, the circuit will be biased towards the transmit side. The resistor value is calculated from:

$$R = R_T \left[ \frac{V_B}{\Delta V} - 1 \right]$$

where R is the added resistor, R<sub>T</sub> is the resistor normally between Pins 14 and 15 (typically 120 kΩ), and ΔV is the difference between V<sub>B</sub> and the voltage at C<sub>T</sub> at idle (refer to Figure 10).

By connecting a resistor from C<sub>T</sub> (Pin 14) to V<sub>CC</sub>, the circuit will be biased towards the receive side. The resistor value is calculated from:

$$R = R_T \left[ \frac{V_{CC} - V_B}{\Delta V} - 1 \right]$$

R, R<sub>T</sub>, and ΔV are the same as above. Switching time will be somewhat affected in each case due to the different voltage excursions required to get to transmit and receive from idle. For practical considerations, the ΔV shift should not exceed 100 mV.

### VOLUME CONTROL

If a potentiometer with a standard linear taper is used for the volume control, the graph of Figure 14 indicates that the receive gain will not vary in a linear manner with respect to the pot's position. In situations where this may be objectionable, a potentiometer with an audio taper (commonly used in radio volume controls) will provide a more linear relationship as indicated in Figure 26. The slight non-linearity at each end of the graph is due to the physical construction of the potentiometer, and will vary among different manufacturers.

FIGURE 26 — RECEIVE ATTENUATOR GAIN versus POTENTIOMETER POSITION USING AUDIO TAPER

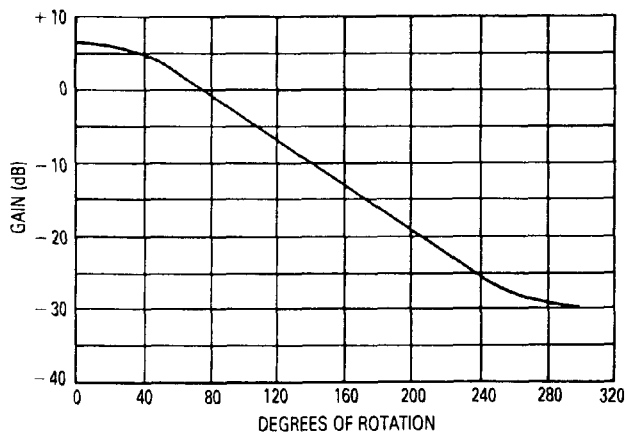

### APPLICATION CIRCUIT

The circuit of Figure 23 is a basic speakerphone, to be used in parallel with any other telephone which con-

tains the ringer, dialer, and handset functions. The circuit is powered entirely by the telephone line's loop current, and its characteristics are shown in Figures 27-30.

FIGURE 27 — DC V-I CHARACTERISTICS

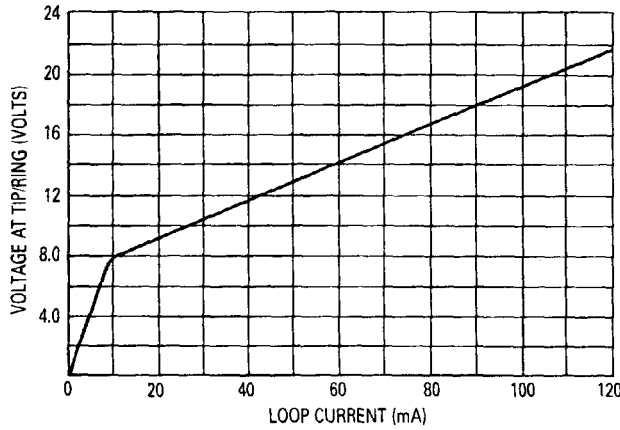

FIGURE 28 — AC TERMINATION IMPEDANCE

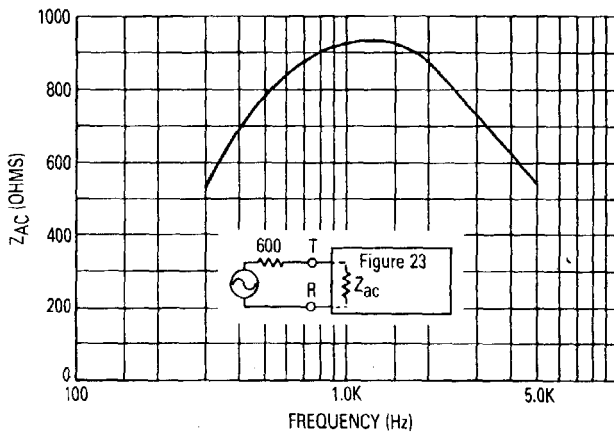

FIGURE 29 — TRANSMIT GAIN — MICROPHONE TO TIP/RING

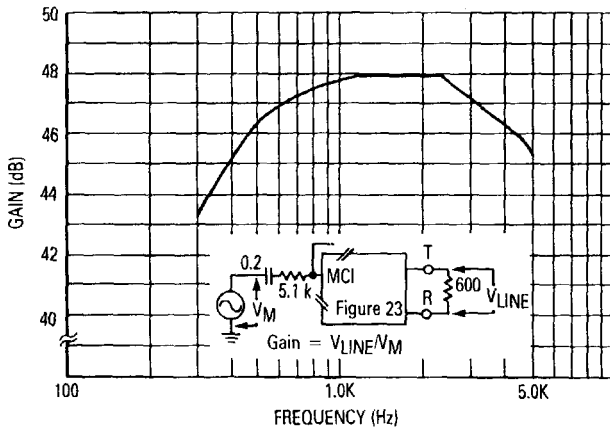

FIGURE 30 — RECEIVE GAIN

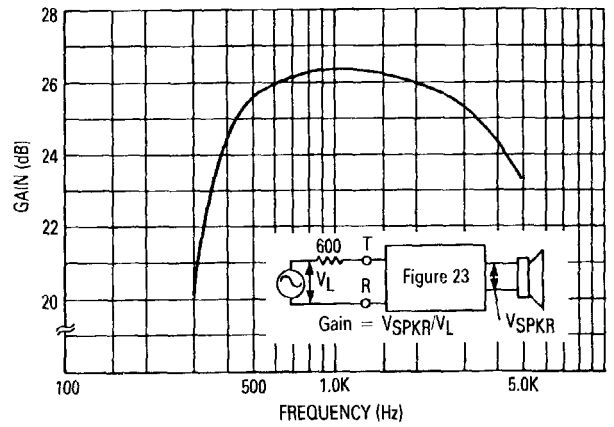
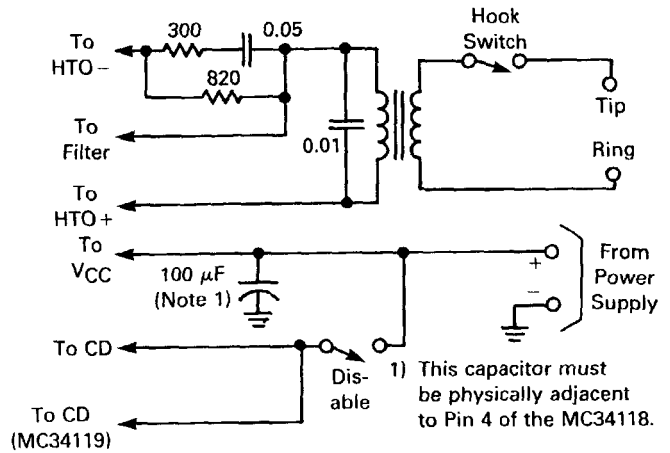

Figure 31 shows how the same circuit can be configured to be powered from a 3.5-6.0 volt power supply rather than the phone line.

FIGURE 31 — OPERATING FROM A POWER SUPPLY



**ADDING A DIALER**

Figure 32 shows the addition of a dialer to the circuit of Figure 23, with the additional components shown in bold. The MC145412 pulse/tone dialer is shown configured for DTMF operation. The DTMF output (Pin 18) is fed to the hybrid amplifiers at HTI, and the DTMF levels at Tip/Ring are adjusted by varying the 39 kΩ resistor. The Mute Output (active low at Pin 11) mutes the microphone amplifier, and attenuates the DTMF signals in the receive path (by means of the 10 k/3.0 k divider). The MC34118 is forced into the fast idle mode during dialing. The 3.0 volt battery provides for memory retention of the dialer's 10 number storage when the circuit is unpowered.

**RFI INTERFERENCE**

Potential radio frequency interference problems should be addressed early in the electrical and mechanical design of the speakerphone. RFI may enter the cir-

cuit through Tip and Ring, through the microphone wiring to the microphone amplifier, or through any of the PC board traces. The most sensitive pins on the MC34118 are the inputs to the level detectors (RLI1, RLI2, TL1, TL2) since, when there is no speech present, the inputs are high impedance and these op amps are in a near open loop condition. The board traces to these pins should be kept short, and the resistor and capacitor for each of these pins should be physically close to the pins. Any other high impedance input pin (MCI, HTI, FI, VLC) should be considered sensitive to RFI signals.

**IN THE FINAL ANALYSIS . . .**

Proper operation of a speakerphone is a combination of proper mechanical (acoustic) design as well as proper electronic design. The acoustics of the enclosure must be considered early in the design of a speakerphone. In general, electronics cannot compensate for poor acoustics, low speaker quality, or any combination of the two. Proper acoustic separation of the speaker and microphone, as described in the Design Equations, is essential. The physical location of the microphone, along with the characteristics of the selected microphone, will play a large role in the quality of the transmitted sound. The microphone and speaker vendors can usually provide additional information on the use of their products.

In the final analysis, the circuits shown in this data sheet will have to be "fine tuned" to match the acoustics of the enclosure, the specific hybrid, and the specific microphone and speaker selected. The component values shown in this data sheet should be considered as starting points only. The gains of the transmit and receive paths are easily adjusted at the microphone and speaker amplifiers, respectively. The switching

response can then be fine tuned by varying (in small steps) the components at the level detector inputs until satisfactory operation is obtained for both long and short lines.

**SUGGESTED VENDORS**

**Microphones**

Primo Microphones Inc.  
Bensenville, IL 60106  
312-595-1022  
Model EM-60

MURA Corp.  
Westbury, N.Y. 11590  
516-935-3640  
Model EC-983-7

Hosiden America Corp.  
Elk Grove Village, IL 60007  
312-981-1144  
Model KUC2123

**25 Ω Speakers**

Panasonic Industrial Co.  
Seacaucus, N.J. 07094  
201-348-5233  
Model EAS-45P19S

**Telecom Transformers**

Microtran Co., Inc.  
Valley Stream, N.Y. 11528  
516-561-6050  
Various models — ask for catalog and Application Bulletin F232

Stancor Products  
Logansport, IN 46947  
219-722-2244  
Various models — ask for catalog

PREM Magnetics, Inc.  
McHenry, IL 60050  
815-385-2700  
Various models — ask for catalog

Onan Power/Electronics  
Minneapolis, MN 55437  
612-921-5600  
Model TC 38-6

**Motorola Inc. does not endorse or warrant the suppliers referenced.**

**FIGURE 32 — ADDING A DIALER TO THE SPEAKERPHONE**

