

MAXIM

+10V Precision Kelvin Sensed References

MAX670/671

General Description

The MAX670/671 are precision +10 volt reference sources with Kelvin connections on both output and ground, which offer superior load regulation and line regulation independent of the line impedance between the reference and load. The MAX670 has initial accuracy of 2.5mV with 3ppm/°C temperature coefficient and the MAX671 is specified with initial accuracy of 1.0mV and temperature coefficient of 1ppm/°C. Both devices are designed to upgrade existing sockets which employ the popular MX2700 and MX2710 series by connecting a few of the unused pins together to obtain improved performance. The MAX670/671 have two methods of fine trim adjustment, one which is an improved technique which will not disturb the output voltage temperature coefficient, and the other is compatible with the MX2700/2710. All parts are packaged in 14 lead ceramic side brazed DIP and include burn-in at +150°C.

Applications

Precision D/A and A/D Converters
 Digital Voltmeters
 Precision Test and Measurement System
 Precision Calibrated Voltage Reference Standard
 High Accuracy Transducers

Typical Operating Circuit

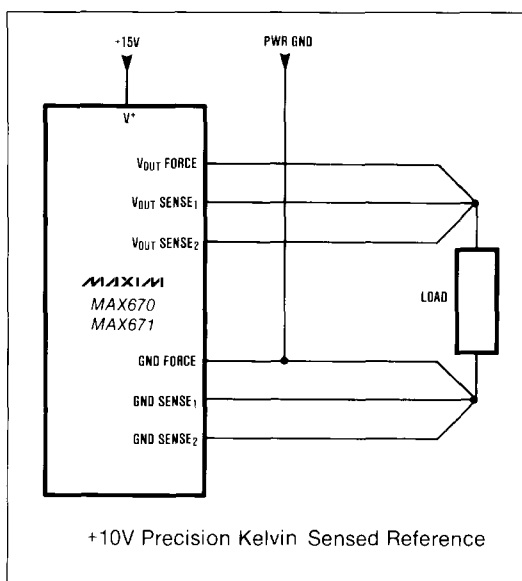

Features

- ◆ Superior Load Regulation: 10μV/mA Max.
- ◆ Superior Line Regulation: 50μV/V Max.
- ◆ Excellent Initial Accuracy: +10V ±1mV Max. (MAX671)
- ◆ Low Temperature Coefficient: 1ppm/°C Max. (MAX671)
- ◆ 10mA Output Current
- ◆ High Current Capability with External Transistor
- ◆ Functionally Compatible with MX2700 and MX2710

Ordering Information

PART	INIT. ACC.	*TEMP. COEFF.	TEMP. RANGE
MAX670CDD	2.5mV	3ppm/°C	0°C to +70°C
MAX670EDD	2.5mV	3ppm/°C	-40°C to +85°C
MAX670MDD	2.5mV	3ppm/°C	-55°C to +125°C
MAX671CDD	1.0mV	1ppm/°C	0°C to +70°C
MAX671EDD	1.0mV	1ppm/°C	-40°C to +85°C
MAX671MDD	1.0mV	1ppm/°C	-55°C to +125°C

(All devices are packaged in a 14 lead ceramic side brazed DIP.)
 *Restricted temperature range (See Electrical Characteristics).

Pin Configuration

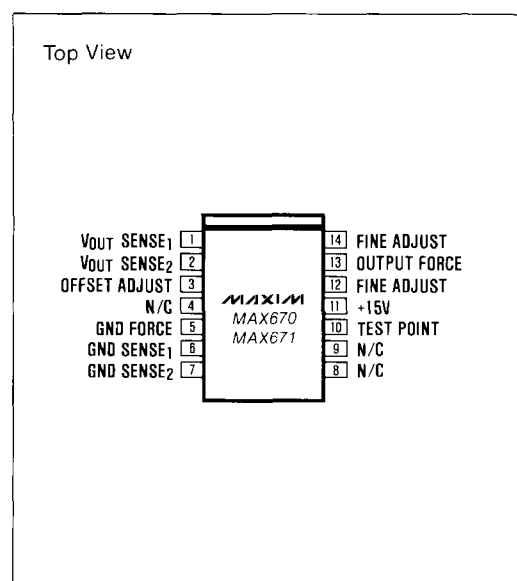

+10V Precision Kelvin Sensed References

ABSOLUTE MAXIMUM RATINGS

Input Voltage	+20V
Power Dissipation	400mW
Operating Temperature Range	-55°C to +125°C
Storage Temperature Range	-65°C to +160°C
Lead Temperature (Soldering, 10 sec)	+300°C
Short Circuit to GND	Continuous

Stresses above those listed under "Absolute Maximum Ratings" may cause permanent damage to the device. These are stress ratings only and functional operation of the device at these or any other conditions above those indicated in the operational sections of the specifications is not implied. Exposure to absolute maximum rating conditions for extended periods may affect device reliability.

ELECTRICAL CHARACTERISTICS

($V_{IN} = +15V$, $T_A = +25^\circ C$, $R_L = 2k\Omega$, unless otherwise indicated)

PARAMETER	SYMBOL	CONDITIONS	MIN	TYP	MAX	UNITS			
Initial Output Voltage	V_O	MAX670	9.9975	10.0000	10.0025	V			
		MAX671	9.9990	10.0000	10.0010				
Output Voltage Drift (See Figures 12 and 13)	$\Delta V_O / \Delta T$	MAX670C T_A to +70°C T_A to 0°C	-3 -5		+3 +3	ppm/°C			
		MAX670E T_A to +85°C T_A to -40°C	-3 -5		+3 +3				
		MAX670M T_A to +85°C T_A to +125°C +85°C to +125°C T_A to -55°C	-3 -5 -10 -5		+3 +3 +3 +3				
		MAX671C T_A to +70°C T_A to 0°C	-1 -5		+1 +1				
		MAX671E T_A to +85°C T_A to -40°C	-1 -5		+1 +1				
		MAX671M T_A to +85°C T_A to +125°C +85°C to +125°C T_A to -55°C	-1 -5 -10 -5		+1 +1 +1 +1				
		Load Regulation	$\Delta V_O / \Delta I_O$	0mA to 10mA to GND MAX670 MAX671				20 10	$\mu V/mA$
		Line Regulation	$\Delta V_O / \Delta V_{IN}$	$V_{IN} = 13.5V$ to 16.5V MAX670 MAX671				100 50	$\mu V/V$
		Input Voltage Range	V_{IN}		13.5			16.5	V
		Supply Current	I_S	No Load			9	14	mA
Noise (Note 1)	e_N	0.1Hz to 10Hz		12	50	μV_{p-p}			
Long Term Stability	$\Delta V_O(T)$	$T_A = +55^\circ C$		50		ppm/ 1K hrs			
Output Adjust Range	ΔV_{ADJ}	per Figure 10		20		mV			
Output Adjust vs. TC	$\frac{\Delta V_O / \Delta T}{\Delta V_{ADJ}}$	per Figure 10		0.4		ppm/ °C/mV			

Note 1: This parameter is sample tested to 10% LTPD, and is not used to calculate outgoing quality level.

+10V Precision Kelvin Sensed References

Theory of Operation

A temperature compensated zener diode is applied to the non-inverting input of an operational amplifier (Figure 1). The zener voltage is amplified and accurately laser trimmed to produce a precise 10.000V. The zener operating current is derived from the regulated output voltage, and actively laser trimmed for the lowest temperature coefficient at the output of the op amp.

The MAX670 and MAX671 each have three Kelvin connections for both output and ground which eliminates errors due to the I-R voltage drops from the resistance of the pins, sockets, and connecting wires. The FORCE pin output current varies as the load changes such that the voltage reflects changes due to I-R drops as well. $V_{OUT\ SENSE1}$ and $GND\ SENSE1$ are the gain resistors of the op amp that are used to maintain a precise voltage the points at the load to which they are connected. The $V_{OUT\ SENSE2}$ and $GND\ SENSE2$ pins when connected in the circuit are constant current points but do not contribute errors from I-R drops as long as they are connected to the same points as $V_{OUT\ SENSE1}$ and $GND\ SENSE1$.

Applications Information

The Force and Sense lines should be connected together as close as possible to the load or reference input of the converter. The power supply ground must be connected either at the same ground point at the load or along the $GND\ FORCE$ path.

The additional benefit of separate Force and Sense lines allows the use of an external buffer for increased output current while maintaining the specified output accuracy. There are several methods of buffering, the choice of which depends on the constraints of the application.

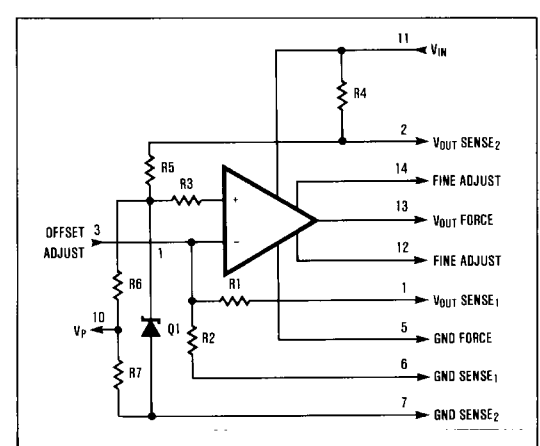

Figure 1. MAX670/671 Schematic Diagram

Emitter Follower

An NPN transistor can be used as a buffer for very low impedance output if only current sourcing (i.e. from Output to GND) is desired (Figure 2). It is advisable to place a small resistor in series with the base of the transistor to prevent oscillation unless the f_T is low. Since the Sense lines will keep the emitter at 10V, the base will rise up to about 10.7V due to the transistor V_{be} . This limits the low end of the supply range, especially at cold temperatures where the V_{be} of the transistor is the largest and the headroom of the internal op amp is lowest. The output of the internal op amp on the Force pin will change as much as necessary over temperature to maintain the Sense pins on the emitter at a constant voltage.

Similarly, a FET (Figure 3) can be used as a source follower. However, the V_T of a N-channel FET must be low, about 2V, so that the MAX670 output will

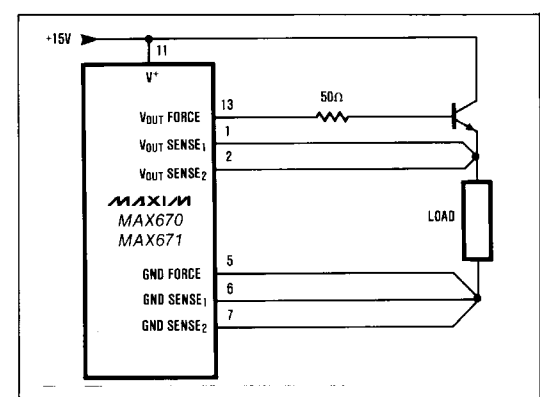

Figure 2. NPN Emitter Follower

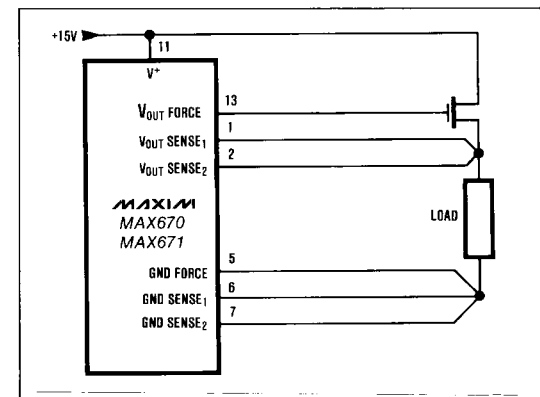

Figure 3. FET Source Follower

+10V Precision Kelvin Sensed References

have sufficient headroom. Alternatively, a P-channel FET, whose gate voltage will be more negative than the source would be more suitable because the op amp output voltage would be driven further into the middle of its output swing range.

If the load only requires the reference to sink current, a PNP transistor can be used as shown in Figure 4.

+12 Volt Operation

A few forward biased diodes in series with the base of the transistor in Figure 5 will drop the MAX670 output by as many V_{be} 's for more op amp headroom and therefore lower operating voltage. Over temperature, the MAX670 $V_{OUT\ FORCE}$ will change as much as required due to the temperature coefficient of the V_{be} 's. One diode will best compensate the V_{be} of the transistor so that the Force output will be close to 10V. However, two diodes will place the internal op amp output at about 9.3V to give enough headroom for 12V $\pm 10\%$ operation (i.e. 11.4V minimum).

External Buffer

A more simple, yet more costly method to increase the output current is by the use of an external buffer amplifier, such as a BUF-03, LH0002, or an LH0033 (Figure 6) for up to 100mA of output current. The Force output drives the buffer input, while the Sense lines maintain the buffer output to the initial +10V

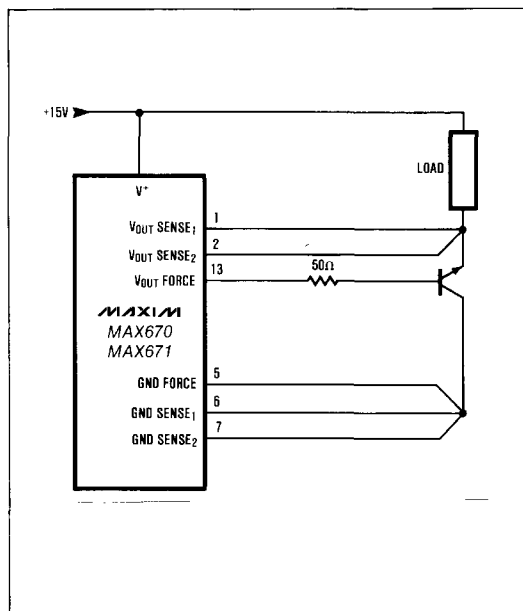

Figure 4. PNP Emitter Follower

value, even if the offset drift is high. $V_{OUT\ SENSE2}$ can be connected to the input of the buffer if necessary, but there will be a small second order error over temperature as the offset drift slightly changes the reference zener operating current. Therefore it is always better to connect both SENSE lines together at the load.

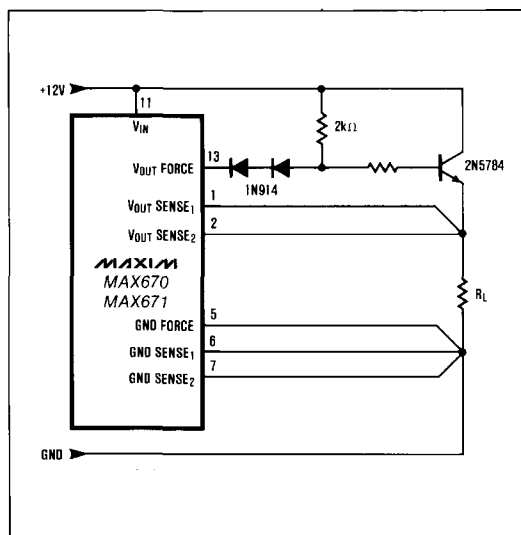

Figure 5. Application Circuit for 12V Operation, 120mA Output Current

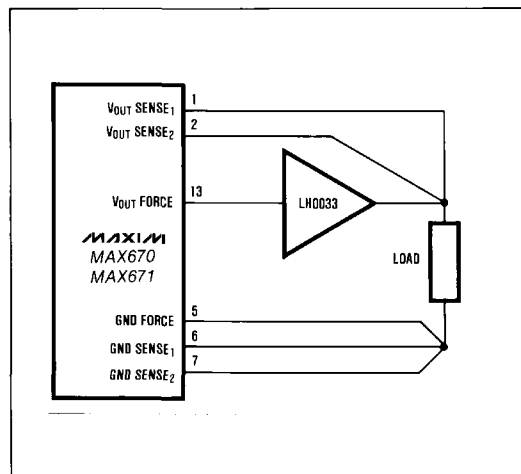

Figure 6. 100mA Output Current with Buffer Amplifier

+10V Precision Kelvin Sensed References

High Power Output

The specified accuracy of the MAX670 can be obtained even at currents of several amps using a Power Amplifier such as the LH0101 as a non-inverting buffer amplifier (Figure 7). By placing the amplifier inside the loop and sensing the output, the reference will have a 2A output capability keeping in mind the heat sink requirements of the LH0101.

High Speed Buffer

In some cases, the reference is required to drive a circuit that contains high speed transients or glitches which must settle back to a steady state value quickly. In this case a fast op amp can be used on the output, such as an HA-2525 or a BB3554 (Figure 7). The high bandwidth of these amplifiers enables them to settle quickly at the expense of higher noise bandwidth that may restrict their applications.

Load Balancing

If the load current is known, and is constant, such as in the case of driving the reference input of numerous D/A converters, a pull up resistor (Figure 8) can be used to match the load current to ground with the MAX670 regulating the output voltage and supplying the error current up to 10mA. For this special case, the cost of an amplifier is eliminated and the circuit complexity is reduced.

Offset Adjust

The output voltage of the MAX670 and MAX671 can be adjusted in two ways. The Offset Adjust Input on pin 3 (Figure 9) has the unique advantage of changing the output voltage without disturbing the temperature coefficient. Also, a wide variety of trim range and resolution can be obtained by appropriate selection of the resistor in series with pin 3 as shown in graph below.

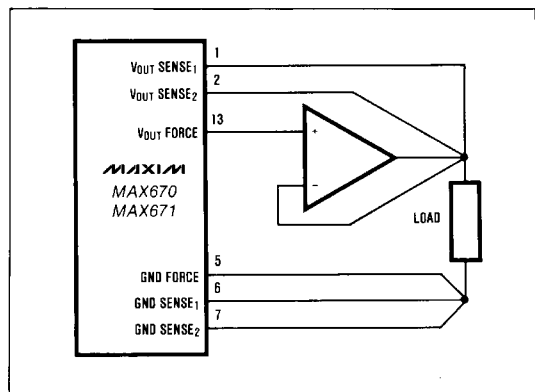

Figure 7. 2A Output Current Using LH0101 Power Amplifier or BB3554 FAST Op-Amp

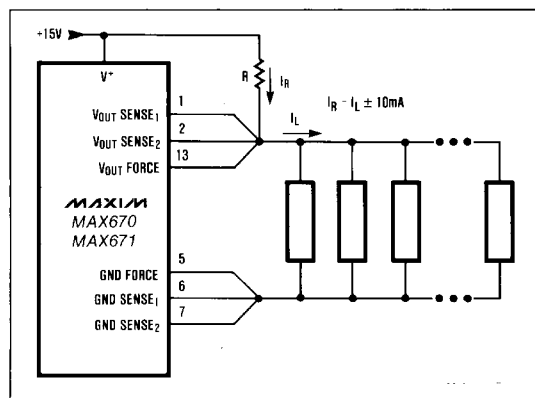
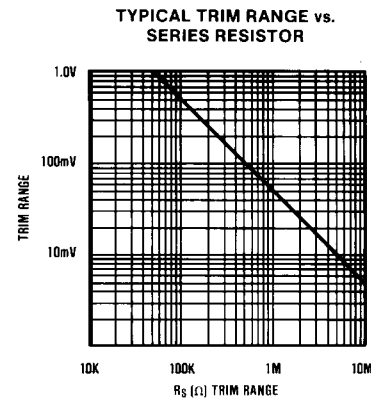

Figure 8. Pull Up Resistor Load Balancing

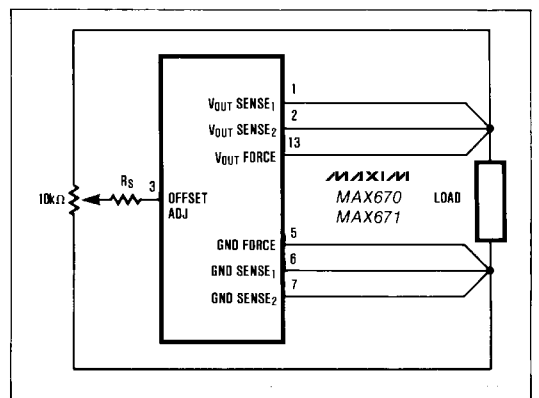

Figure 9. MAX670/671 Improved TC Independent Trim Adjustment

+10V Precision Kelvin Sensed References

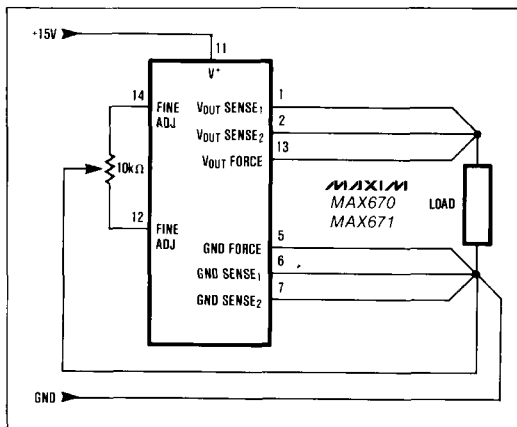

Figure 10. MX2700/2710 Compatible Trim Adjustment

The other adjustment method is designed to be compatible with the MX2700/MX2710 series of references. A potentiometer is connected between pins 12 and 14 with the wiper to ground (Figure 10), but this method affects the output temperature coefficient by approximately 0.4ppm/°C per millivolt of adjustment.

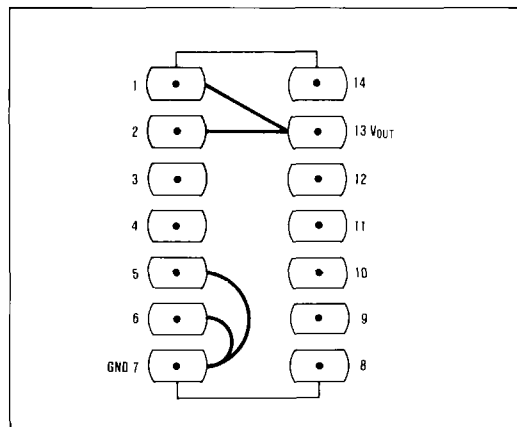

Figure 11. Using MAX670/671 in MX2700/2710 Sockets

Upgrading MX2700/MX2710

Any existing socket containing an MX2700 or MX2710 can be easily adapted to the MAX670 or MAX671 by shorting pin 13 to pins 1 and 2, and also shorting pin 7 to pins 5 and 6 (Figure 11).

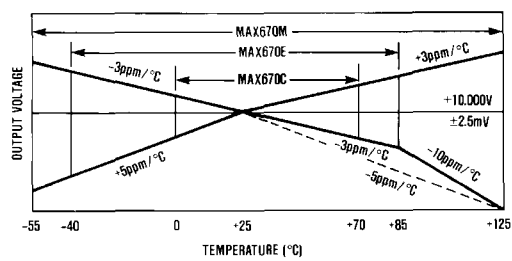

Figure 12. MAX670 Temperature Coefficient

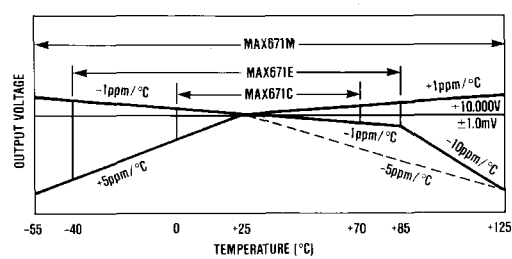
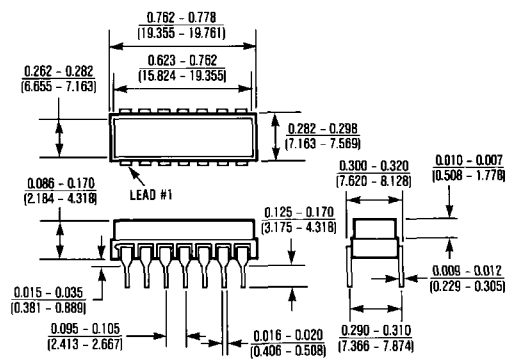

Figure 13. MAX671 Temperature Coefficient

Package Information



14 Lead HYBRID
 $\theta_{JA} = 100^{\circ}\text{C/W}$
 $\theta_{JC} = 45^{\circ}\text{C/W}$