

PRELIMINARY DATA

RHYTHM GENERATORS

- 16 PROGRAMMABLE RHYTHMS (CODED FOR THE M258; ALSO AVAILABLE IN COMBINATION FOR THE M259)
- 16 OUTPUTS (2 SECTIONS BY 8)
- MASK PROGRAMMABLE RESET COUNTS (24 or 32)
- DOWN BEAT OUT
- SYNC OUT
- EXTERNAL RESET
- TWO CHIP SELECTS (CS1, CS2) FOR SEPARATE TRISTATE CONDITION OF THE TWO OUTPUT SECTIONS
- INTERNAL PULL-UP ON THE INPUTS
- OPEN DRAIN OUTPUTS WITH RETURN TO "1" STATUS
- CHOICE BETWEEN RETURN TO "1" OR NOT ON 8 OUTPUTS (OUT 1, 2, 3, 4, 9, 10, 11, 12) SEPARATELY
- ONLY ONE POWER SUPPLY (+5V)
- VERY LOW POWER CONSUMPTION (150 mW TYP.)

The M258, M259 are monolithic rhythm generators specifically designed for electronic organs and other musical instruments.

Constructed on a single chip using MOS N-channel silicon gate technology, they are supplied in a 28 lead for (M258) or 40 lead for (M259) dual in-line plastic package.

ABSOLUTE MAXIMUM RATINGS*

V_{DD}^{**}	Source supply voltage	-0.3 to +7	V
V_i^{**}	Input voltage	-0.3 to +7	V
I_o	Output current (at any pin)	3	mA
V_{OH}	Output voltage	12	V
T_{stg}	Storage temperature range	-65 to +125	°C
T_{op}	Operating temperature range	0 to 50	°C

* Stresses above those listed under "Absolute Maximum Ratings" may cause permanent damage to the device. This is a stress rating only and functional operation of the device at these or any other conditions above those indicated in the operational sections of this specification is not implied. Exposure to absolute maximum rating conditions for extended periods may affect device reliability.

** All voltages are with respect to V_{SS} (GND).

ORDERING NUMBERS: M258 B1/EB1 for dual in-line plastic package
M259 B1/EB1 for dual in-line plastic package



M 258
M 259

MECHANICAL DATA (dimensions in mm)

Dual in-line plastic package (28 lead)

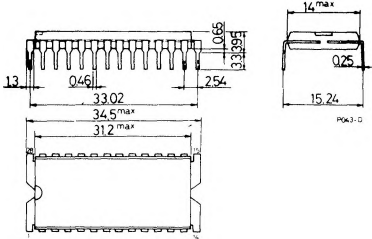

Dual in-line plastic package (40 lead)

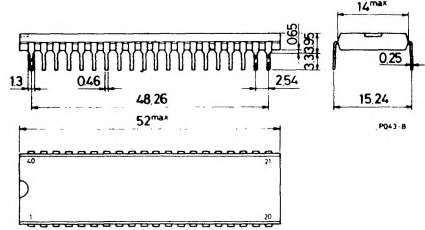

PIN CONNECTIONS

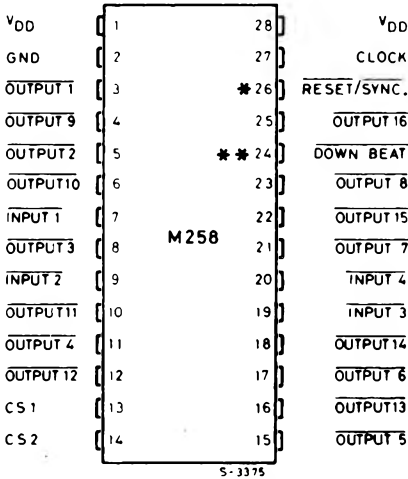

CS1 enables the outputs 01 to 08
CS2 enables the outputs 09 to 16

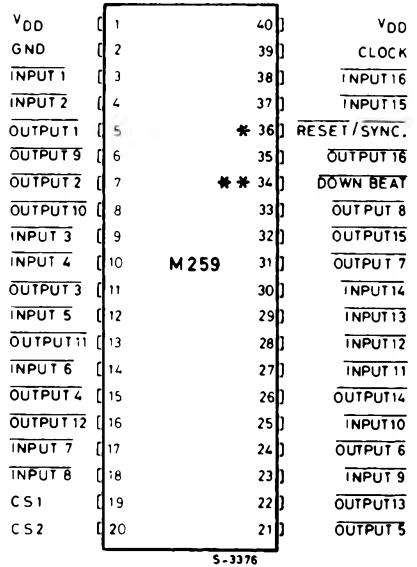

* This is a bidirectional pin. Used as an input it allows the chip reset; used as an output it can reset other devices.

** This pin generates a down beat trigger which can be used to drive an external lamp to indicate the first beat of the first bar of each rhythm.

RESET AND DOWN BEAT TIMING WAVEFORMS (POSITIVE LOGIC)

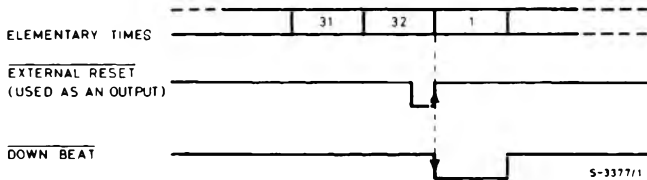

BLOCK DIAGRAM

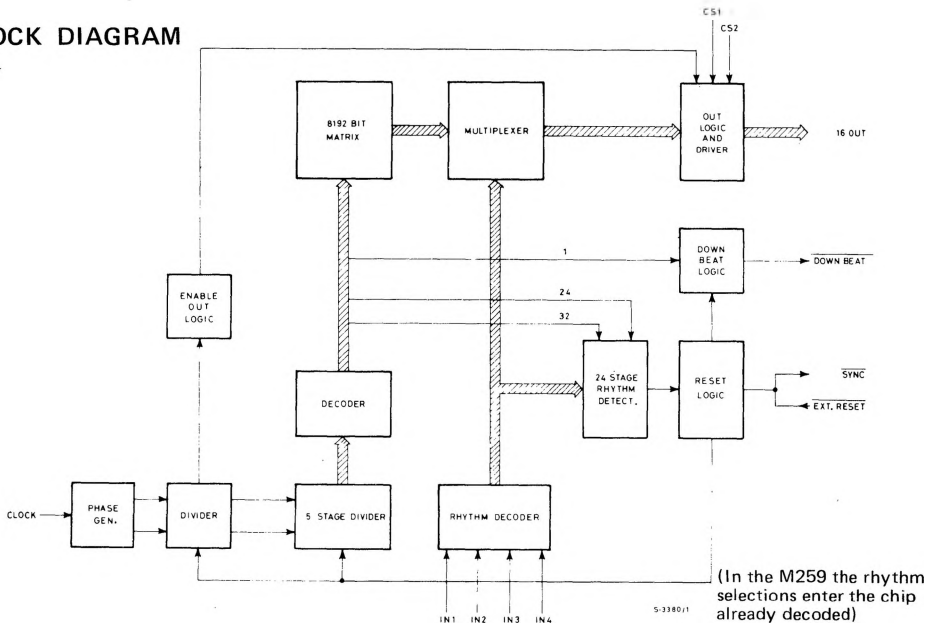

RHYTHM, SELECTION (for M258 only)

Rhythm	IN4	IN3	IN2	IN1
1	1	1	1	1
2	1	1	1	0
3	1	1	0	1
4	1	1	0	0
5	1	0	1	1
6	1	0	1	0
7	1	0	0	1
8	1	0	0	0
9	0	1	1	1
10	0	1	1	0
11	0	1	0	1
12	0	1	0	0
13	0	0	1	1
14	0	0	1	0
15	0	0	0	1
16	0	0	0	0

STATIC ELECTRICAL CHARACTERISTICS(positive logic, $V_{DD} = 4.75$ to $5.25V$, $T_{amb} = 0$ to $50^{\circ}C$ unless otherwise specified)

Parameter	Test conditions	Values			Unit
		Min.	Typ.	Max.	

CLOCK INPUT

V_{IH}	Clock high voltage		2.4		V_{DD}	V
V_{IL}	Clock low voltage		0		0.4	V

DATA INPUTS

V_{IH}	Input high voltage		2.4		V_{DD}	V
V_{IL}	Input low voltage		0		0.4	V
R_{IN}	Internal resistance to V_{DD}	$V_i = 0V$	$V_{DD} = 5V$	100	180	$K\Omega$
$I_{OL}^{(*)}$	Input load current	$V_i = V_{IL}$			-50	μA

EXT. RESET

V_{IH}	Input high voltage		4.5		V_{DD}	V	
V_{IL}	Input low voltage		0		1.5	V	
R_{OFF}	Internal resistance to V_{DD} (inactive sync)	$V_O = 0$	$V_{DD} = 5V$	100	180	$K\Omega$	
R_{ON}	Internal resistance to V_{DD} (active sync)	$V_O = 1V$	$V_{DD} = 4.75V$		260	300	Ω

OUTPUTS (O_i , Down beat)

R_{ON}		$V_O = 1V$		260	300	Ω
V_{OL}		Source current = 1 mA		0.26	0.3	V
I_{LO}		$V_O = 12V$	$T_{amb} = 25^{\circ}C$		10	μA

POWER DISSIPATION

I	Supply current	$T_{amb} = 25^{\circ}C$		30		mA
---	----------------	-------------------------	--	----	--	----

(*) The "High Level" is clamped by the internal pull-up.

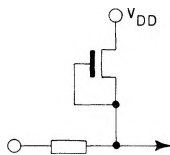

DYNAMIC ELECTRICAL CHARACTERISTICS (positive logic, $V_{DD} = 4.75$ to $5.25V$, $T_{amb} = 0$ to $50^{\circ}C$ unless otherwise specified)

Parameter	Test conditions	Values			Unit
		Min.	Typ.	Max.	

CLOCK INPUT

f	Clock repetition rate		DC		100	KHz
t_w	Pulse width	Measured at 50% of the swing		5		μs
t_r	Rise time	Measured between 10% and 90% of the swing			100	μs
t_f	Fall time	Measured between 10% and 90% of the swing			100	μs

EXT. RESET

t_{wR}	Pulse width		100			μs
t_{CR}	Clock delay with respect to reset		0			μs

TIMING WAVEFORMS

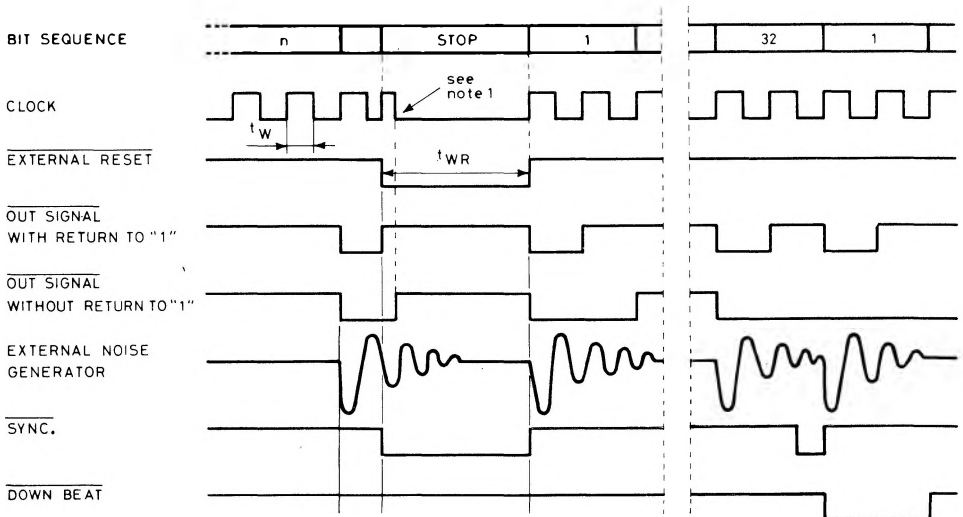

Note 1: This additional pulse, to reset the outputs without return to "1", can be obtained by using a clock generator as shown in the following diagram:

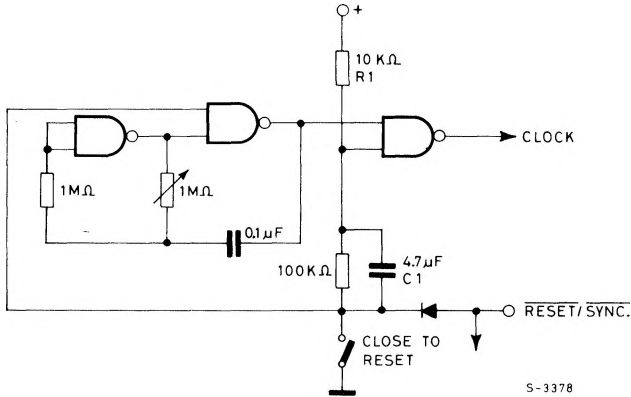

Ext. Reset/Sync. is a bidirectional pin. Used as an input it can reset the circuit as shown in the timing diagram and used as an output it can drive the reset of other devices.

Using the clock generator shown in the above figure, when the switch is closed asynchronous with respect to the clock, it is possible to have two cases (see the following diagrams); in both the cases the output reset can be obtained by CS1 and CS2.

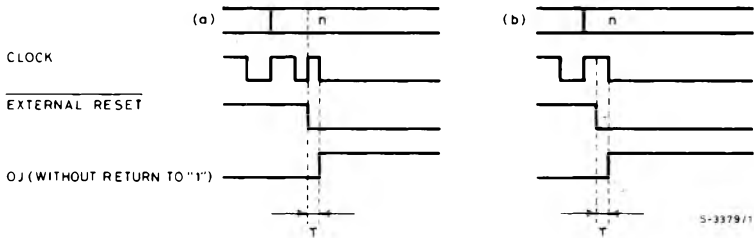

In both the cases the delay τ (in the outputs without return to "1") is defined through the constant $R1 C1 \geq 10 \mu\text{sec}$.



INSTRUMENT BEATS VERSUS RHYTHM PROGRAM

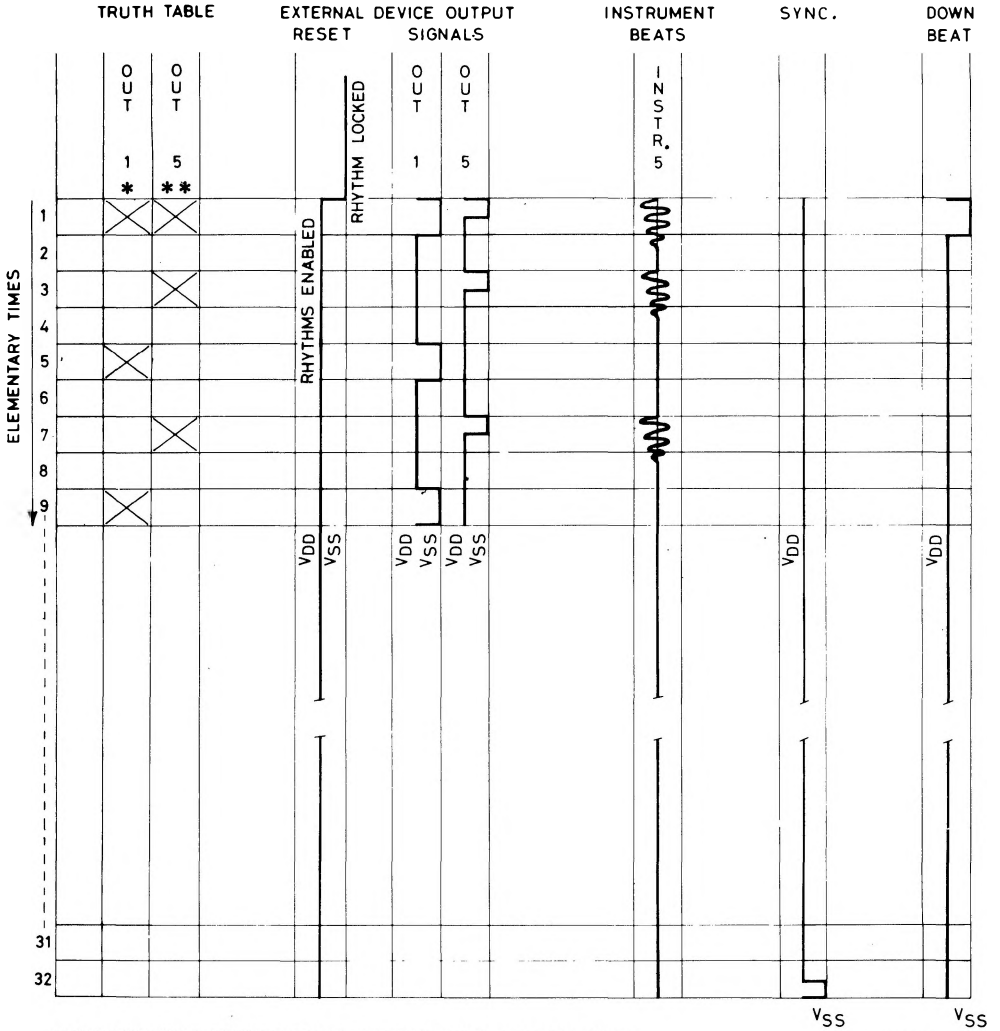

* OUT 1 WITHOUT RETURN TO "1" - ** OUT 5 WITH RETURN TO "1"

S-3353/1

Note: The outputs 01 to 08 are enabled by CS1; the outputs 09 to 16 are enabled by CS2. The outputs 01 to 04 and 09 to 12 are programmable separately without return to "1".