

VERY LOW DROP 1A REGULATOR

PRELIMINARY DATA

- LOW DROPOUT VOLTAGE (450mV TYP AT 1A)
- VERY LOW QUIESCENT CURRENT
- THERMAL SHUTDOWN
- SHORT CIRCUIT PROTECTION
- REVERSE POLARITY PROTECTION

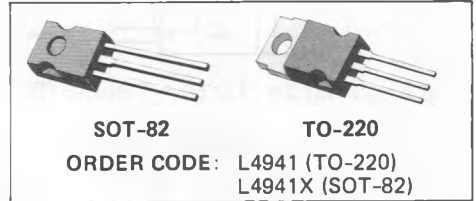

INTRODUCTION

The L4941/X is a three terminal 5V positive regulator available in TO-220 and SOT-82 packages; making it useful in a wide range of the industrial and consumer applications. Thanks to its very low input/output voltage drop, this device

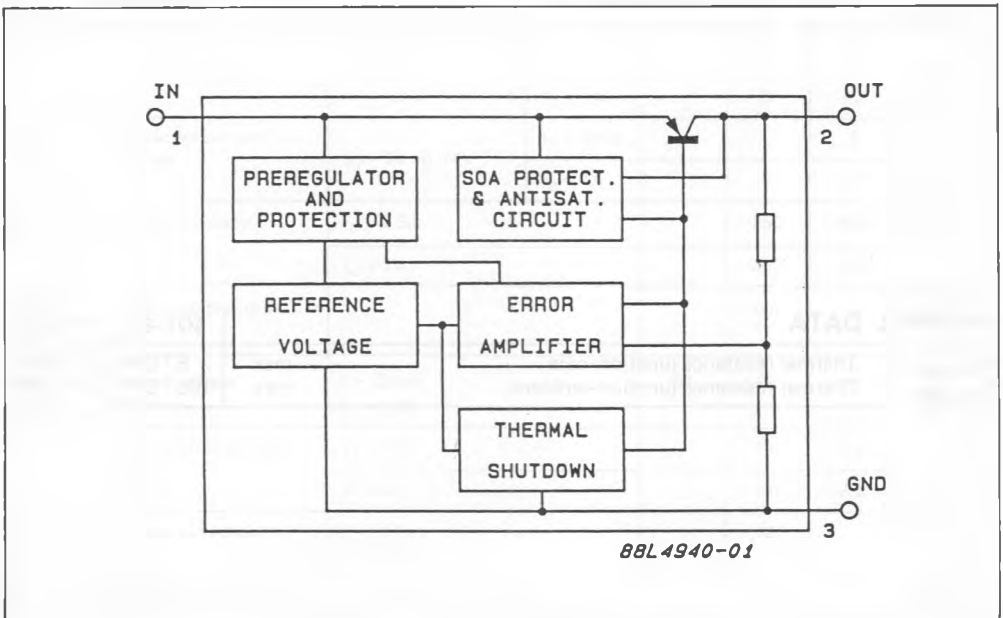
is particularly suitable for battery powered equipment, reducing consumption and prolonging battery life. It employs internal current limiting, antisaturation circuit, thermal shutdown and safe area protection.

BLOCK DIAGRAM

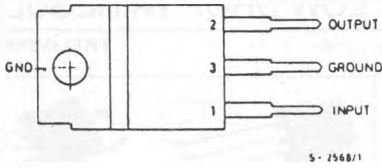
PIN CONNECTIONS



TO-220

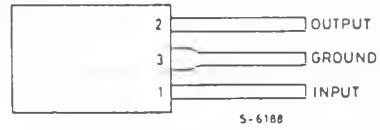

SOT-82

ABSOLUTE MAXIMUM RATINGS

V_i	Forward input voltage	30	V
V_{iR}	Reverse input voltage ($R_O = 100\Omega$)	-15	V
I_O	Output current	Internally limited	
P_{tot}	Power dissipation	Internally limited	
T_j, T_{stg}	Junction and storage temperature	-40 to 150	°C

THERMAL DATA

			SOT-82	TO-220
$R_{th j-case}$	Thermal resistance junction-case	max	8 °C/W	3 °C/W
$R_{th j-amb}$	Thermal resistance junction-ambient	max	100 °C/W	50 °C/W

TEST CIRCUITS

Fig. 1 - DC Parameters

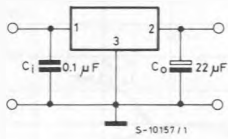

Fig. 2 - Load Regulation

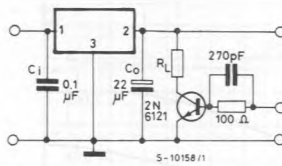
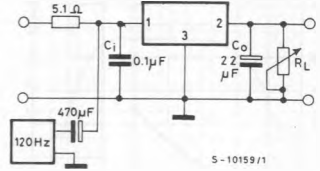

Fig. 3 - Ripple Rejection



ELECTRICAL CHARACTERISTICS (Refer to the test circuits $T_j = 25^\circ\text{C}$, $C_1 = 0.1\mu\text{F}$, $C_0 = 22\mu\text{F}$, unless otherwise specified)

Parameter	Test Conditions	Min.	Typ.	Max.	Unit
OUTPUT VOLTAGE		5			
INPUT VOLTAGE (unless otherwise specified)		7			
V_o	Output voltage $I_o = 5\text{mA to } 1\text{A}$ $V_i = 6\text{V to } 14\text{V}$	4.8	5	5.2	V
V_i	Operating input voltage $I_o = 5\text{mA}$			16	V
ΔV_o	Line regulation $V_i = 6\text{V to } 16\text{V}$ $I_o = 5\text{mA}$		5	20	mV
ΔV_o	Load regulation $I_o = 5\text{mA to } 1\text{A}$ $I_o = 0.5\text{A to } 1\text{A}$		8 5	20 15	mV
I_Q	Quiescent current $V_i = 6\text{V}$	$I_o = 5\text{mA}$	4	8	mA
		$I_o = 1\text{A}$	20	40	
ΔI_Q	Quiescent current change $V_i = 6\text{V to } 14\text{V}$	$I_o = 5\text{mA}$		3	mA
		$I_o = 1\text{A}$		-10	
V_d	Dropout voltage $I_o = 0.5\text{A}$ $I_o = 1\text{A}$		250	450	mV
			450	700	
$\frac{\Delta V_o}{\Delta T}$	Output voltage drift		0.6		mV/°C
SVR	Supply voltage rejection $f = 120\text{Hz}$ $I_o = 0.5\text{A}$	58	68		dB
I_{sc}	Short circuit current limit $V_i = 14\text{V}$ $V_i = 6\text{V}$		1.6	2.0	A
			1.8	2.2	
Z_o	Output impedance $f = 1\text{KHz}$ $I_o = 0.5\text{A}$		30		mΩ
e_N	Output noise voltage $B = 100\text{Hz to } 100\text{KHz}$		30		$\mu\text{V}/V_o$

Fig. 4 - Dropout voltage vs. output current

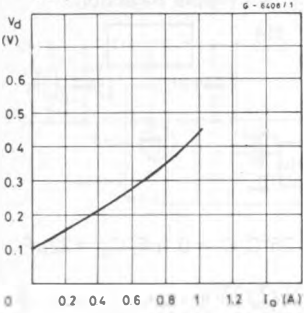

Fig. 5 - Dropout voltage vs. temperature

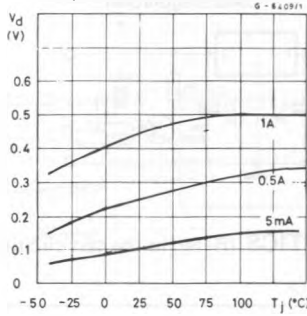

Fig. 6 - Output voltage vs. temperature

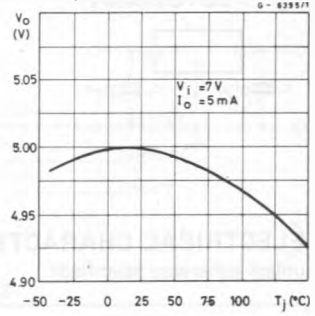

Fig. 7 - Quiescent current vs. temperature

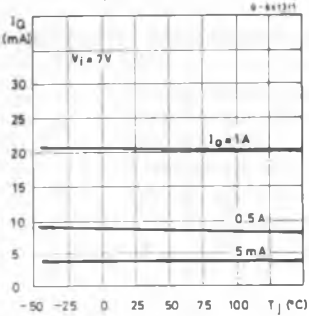

Fig. 8 - Quiescent current vs. input voltage

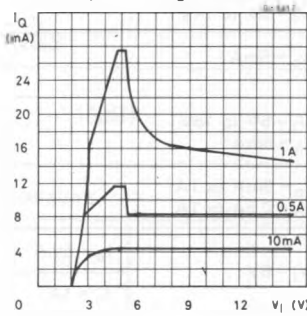

Fig. 9 - Quiescent current vs. output current

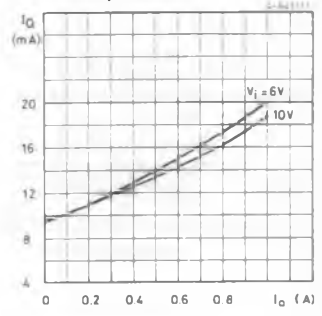

Fig. 10 - Short circuit current vs. temperature

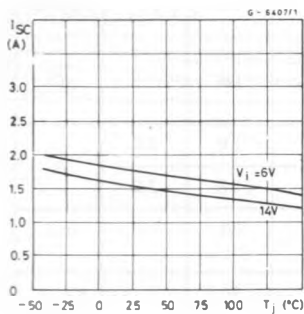

Fig. 11 - Peak output current vs. input/output differential voltage

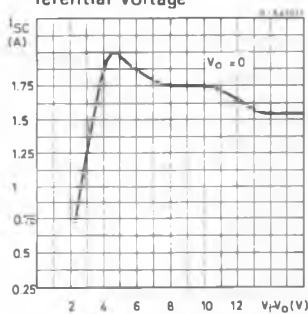

Fig. 12 - Low voltage behavior

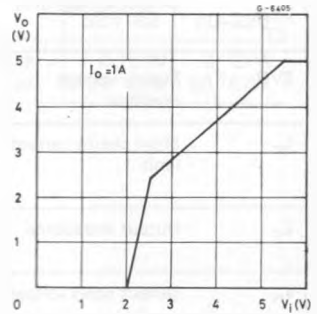

Fig. 13 - Supply voltage rejection vs. frequency

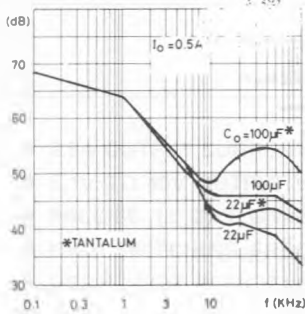

Fig. 14 - Supply voltage rejection vs. output current

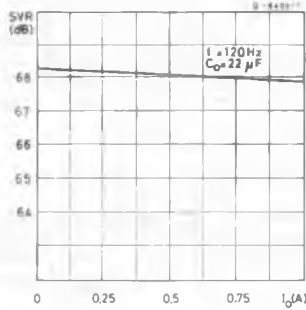

Fig. 15 - Load dump characteristics

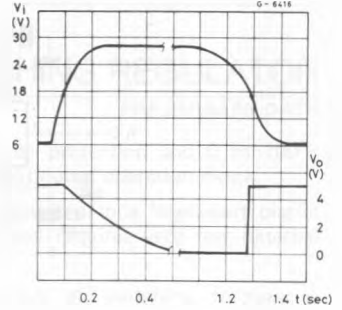

Fig. 16 - Line transient response

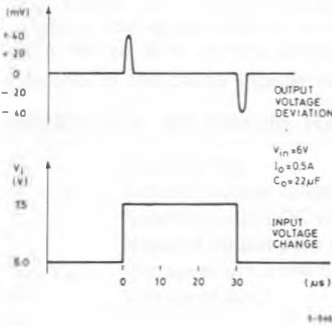

Fig. 17 - Load transient response

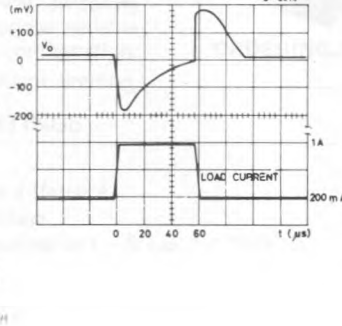

Fig. 18 - Totale power dissipation (TO-220)

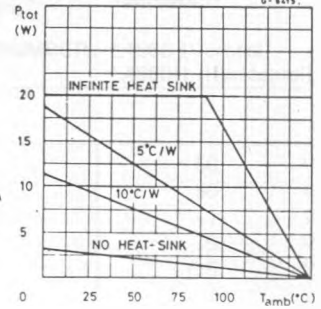
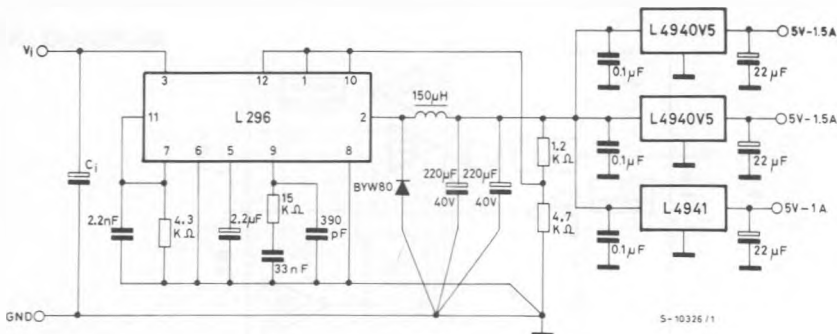

Fig. 19 - Distributed supply with on-card L4940 and L4941 low-drop regulators



ADVANTAGES OF THESE APPLICATIONS ARE:

- On card regulation with short circuit and thermal protection on each output.
- Very high total system efficiency due to the switching preregulation and very low-drop postregulations.

Fig. 20 - Distributed supply with on-card L4940 and L4941 low-drop regulators

