

# CLC522

*CLC522 Wideband Variable Gain Amplifier*



Literature Number: SNOS830B

# CLC522

## Wideband Variable Gain Amplifier

### General Description

The CLC522 variable gain amplifier (VGA) is a dc-coupled, two-quadrant multipliers with differential voltage inputs and a single-ended voltage output. Two input buffers and an output operational amplifier are integrated with the multiplier core and make the CLC522 a complete VGA system that does not require external buffering.

The CLC522 provides the flexibility of externally setting the maximum gain with only two external resistors. Greater than 40dB gain control is easily achieved through a single high impedance voltage input. The CLC522 provides a linear (in Volts per Volt) relationship between the amplifier's gain and the gain-control input voltage.

The CLC522's maximum gain may be set anywhere over a nominal range of 2V/V to 100V/V. The gain control input then provides attenuation from the maximum setting. For example, set for a maximum gain of 100V/V, the CLC522 will provide a 100V/V to 1V/V gain control range by sweeping the gain control input voltage from +1 to -0.98V.

Set at a maximum gain of 10V/V, the CLC522 provides a 165MHz signal channel bandwidth and a 165MHz gain control bandwidth. Gain nonlinearity over a 40dB gain range is 0.5% and gain accuracy at  $A_{V_{max}} = 10V/V$  is typically  $\pm 0.3\%$ .

### Features

- 330MHz signal bandwidth:  $A_{V_{max}} = 2$
- 165MHz gain control bandwidth
- $0.3^\circ$  to 60MHz linear phase deviation
- 0.04% (-68dB) signal-channel non-linearity
- >40dB gain adjustment range

- Differential or single end voltage inputs
- Single-ended voltage output

### Applications

- Variable attenuators
- Pulse amplitude equalizers
- HF modulators
- Automatic gain control & leveling loops
- Video production switching
- Differential line receivers
- Voltage controlled filters

Gain vs. Gain Control Voltage ( $V_g$ )

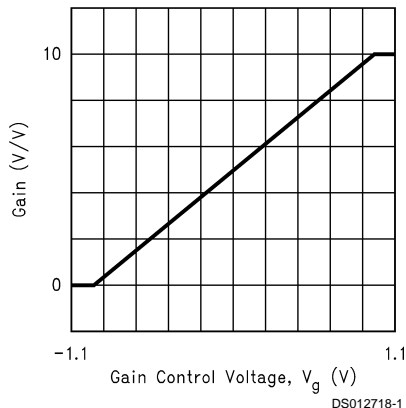

### Connection Diagram

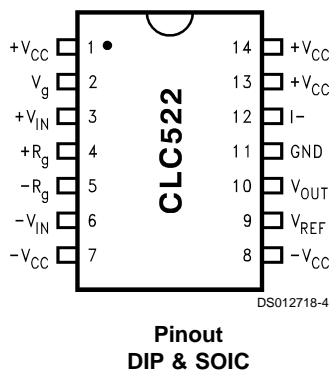

## Typical Application

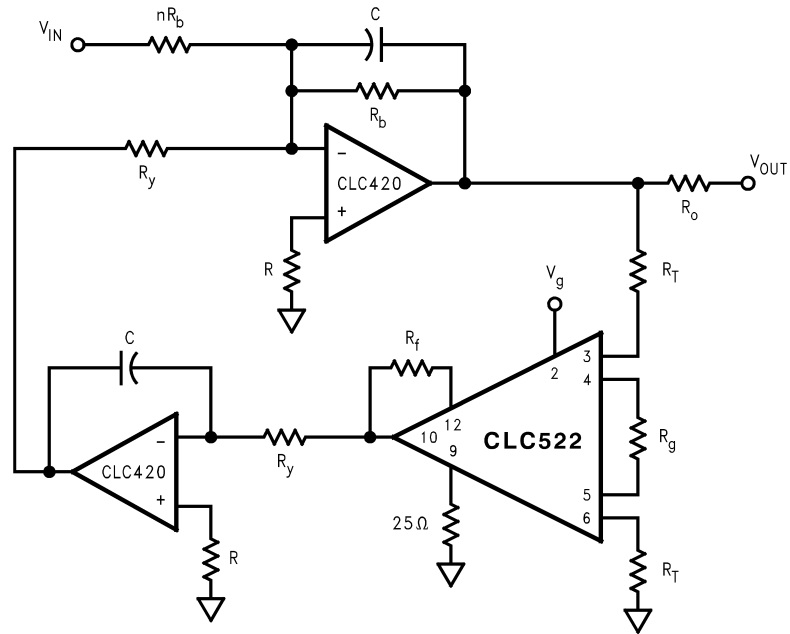

DS012718-2

2nd Order Tuneable Bandpass Filter

$$\frac{V_O}{V_{IN}} = \left( -\frac{1}{n} \right) \frac{s \frac{1}{CR_b}}{s^2 + s \frac{1}{CR_b} + \frac{k}{C^2 R_y^2}}$$

$$k = 1.85 \frac{R_f}{R_y}, \quad Q = \frac{\sqrt{kR_b}}{R_y}, \quad \omega_o = \frac{\sqrt{k}}{CR_y}$$

DS012718-3

## Ordering Information

Package	Temperature Range Industrial	Part Number	Package Marking	NSC Drawing
14-pin plastic DIP	-40°C to +85°C	CLC522AJP	CLC522AJP	N14A
14-pin plastic SOIC	-40°C to +85°C	CLC522AJE	CLC522AJE	M14A, B

**Absolute Maximum Ratings** (Note 1)

If Military/Aerospace specified devices are required, please contact the National Semiconductor Sales Office/ Distributors for availability and specifications.

Supply Voltage	±7V
Short Circuit Current	80mA
Common-Mode Input Voltage	±V <sub>CC</sub>
Maximum Junction Temperature	+200°C
Storage Temperature Range	-65°C to +150°C

Lead Temperature (Soldering 10 sec)

+300°C

**Operating Ratings**

Thermal Resistance		
Package	( $\theta_{JC}$ )	( $\theta_{JA}$ )
MDIP	55°C/W	100°C/W
SOIC	35°C/W	105°C/W

**Electrical Characteristics**(V<sub>CC</sub> = ±5 V; A<sub>Vmax</sub> = +10; R<sub>f</sub> = 1kΩ; R<sub>g</sub> = 182Ω; R<sub>L</sub> = 100Ω; V<sub>g</sub> = +1.1V)

Symbol	Parameter	Conditions	Typ	Min/Max Ratings (Note 2)			Units
Ambient Temperature		CLC522AJE, AJP	+25°C	+25°C	0 to +70°C	-40 to +85°C	
<b>Frequency Domain Response</b>							
	-3dB Bandwidth (Note 7)	V <sub>OUT</sub> < 0.5V <sub>PP</sub>	165	120	115	110	MHz
		V <sub>OUT</sub> < 5.0V <sub>PP</sub>	150	100	95	90	MHz
	Gain Control Bandwidth (Note 5)	V <sub>OUT</sub> < 0.5V <sub>PP</sub>	165	120	115	110	MHz
	Gain Flatness	V <sub>OUT</sub> < 0.5V <sub>PP</sub>					
	Peaking (Note 7)	DC to 30MHz	0	0.1	0.1	0.1	dB
	Rolloff (Note 7)	DC to 30MHz	0.05	0.25	0.25	0.4	dB
	Linear Phase Deviation	DC to 60MHz	0.3	1.0	1.1	1.2	deg
	Feedthrough (Note 7), (Note 6)	30MHz	-62	-57	-57	-57	dB
<b>Time Domain Response</b>							
	Rise and Fall Time	0.5V Step	2.2	2.9	3.0	3.2	ns
		5.0V Step	3.0	5.0	5.0	5.0	ns
	Settling Time	2.0V Step to 0.1%	12	18	18	18	ns
	Overshoot	0.5V Step	2	15	15	15	%
	Slew Rate	4.0V Step	2000	1400	1400	1400	V/μs
<b>Distortion And Noise Response</b>							
	2nd Harmonic Distortion (Note 7)	2V <sub>PP</sub> , 20MHz	-50	-44	-44	-44	dBc
	3rd Harmonic Distortion (Note 7)	2V <sub>PP</sub> , 20MHz	-65	-58	-56	-54	dBc
	Equivalent Input Noise	1 to 200MHz	5.8	6.2	6.5	6.8	nV/√Hz
	Noise Floor	1 to 200MHz	-152	-150	-149	-149	dBm (1Hz)
<b>Gain Accuracy</b>							
	Signal Channel Nonlinearity (SGNL) (Note 4)	V <sub>OUT</sub> = ±2V <sub>PP</sub>	0.04	0.1	0.1	0.1	%
	Gain Control Nonlinearity (GCNL) (Note 4)	Full Range	0.5	2.0	2.2	3.0	%
	Gain Error (GACCU) (Note 4)	A <sub>Vmax</sub> = +10	±0.0	±0.5	±0.5	±1.0	dB
	V <sub>g</sub> High		+990	+990±60	+990±60	+990±60	mV
	V <sub>g</sub> Low		-975	-975±80	-975±80	-975±80	mV
<b>Static, DC Performance</b>							
	V <sub>IN</sub> Voltage Range	Common Mode	±2.2	±1.2	±1.2	±1.4	V
	Bias Current (Note 4)		9	21	26	45	μA
	Average Drift		65	-	175	275	nA/°C
	Offset Current (Note 4)		0.2	2.0	3.0	4.0	μA
	Average Drift		5	-	30	40	nA/°C
	Resistance		1500	650	450	175	kΩ
	Capacitance		1.0	2.0	2.0	2.0	pF

## Electrical Characteristics (Continued)

( $V_{CC} = \pm 5\text{ V}$ ;  $A_{V_{max}} = +10$ ;  $R_f = 1\text{ k}\Omega$ ;  $R_g = 182\Omega$ ;  $R_L = 100\Omega$ ;  $V_g = +1.1\text{ V}$ )

Symbol	Parameter	Conditions	Typ	Min/Max Ratings (Note 2)				Units
<b>Static, DC Performance</b>								
	$V_g$ Bias Current		15	38	47	82	$\mu\text{A}$	
	Average Drift		125	-	300	600	$\text{nA}/^\circ\text{C}$	
	Resistance		100	38	30	15	$\text{k}\Omega$	
	Capacitance		1.0	2.0	2.0	2.0	$\text{pF}$	
	Output Voltage Range	$R_L = \infty$	$\pm 4.0$	$\pm 3.7$	$\pm 3.6$	$\pm 3.5$	V	
	Current		$\pm 70$	$\pm 47$	$\pm 40$	$\pm 25$	$\text{mA}$	
	Offset Voltage (Note 4)	$A_{V_{max}} = +10$	25	85	95	120	mV	
	Average Drift		100	-	350	400	$\mu\text{V}/^\circ\text{C}$	
	Resistance		0.1	0.2	0.3	0.6	$\Omega$	
	$I_{R_{gmax}}$		1.8	1.37	1.26	1.15	$\text{mA}$	
	Power Supply Sensitivity (Note 7)	Output Referred	10	40	40	40	$\text{mV}/\text{V}$	
	Common Mode Rejection Ratio	Input Referred	70	59	59	59	$\text{dB}$	
ICC	Supply Current (Note 4)	$R_L = \infty$	46	61	62	63	$\text{mA}$	

**Note 1:** "Absolute Maximum Ratings" are those values beyond which the safety of the device cannot be guaranteed. They are not meant to imply that the devices should be operated at these limits. The table of "Electrical Characteristics" specifies conditions of device operation.

**Note 2:** Min/max ratings are based on product characterization and simulation. Individual parameters are tested as noted. Outgoing quality levels are determined from tested parameters.

**Note 3:** AJE (SOIC) is tested/guaranteed with  $R_f = 866\Omega$  and  $R_g = 165\Omega$

**Note 4:** J-level: spec. is 100% tested at  $+25^\circ\text{C}$ , sample tested at  $+85^\circ\text{C}$ .

**Note 5:** Tested with  $V_{IN} = 0.2\text{ V}$  and  $V_g < 0.5V_{PP}$

**Note 6:** Feedthrough is tested at maximum attenuation (i.e.,  $V_g = -1.1\text{ V}$ )

**Note 7:** J-level, spec is sample tested at  $25^\circ\text{C}$ .

## Typical Performance Characteristics

Frequency Response ( $A_{V_{max}} = 2$ )

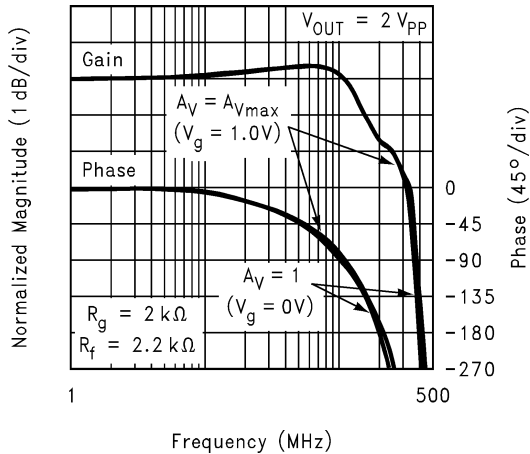

Frequency Response ( $A_{V_{max}} = 10$ )

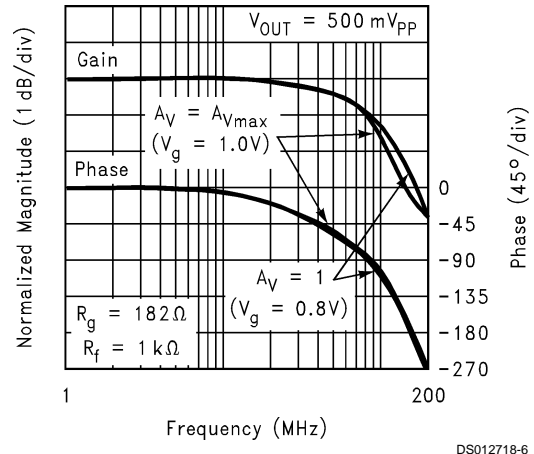

# Typical Performance Characteristics (Continued)

**Frequency Response ( $A_{Vmax} = 100$ )**

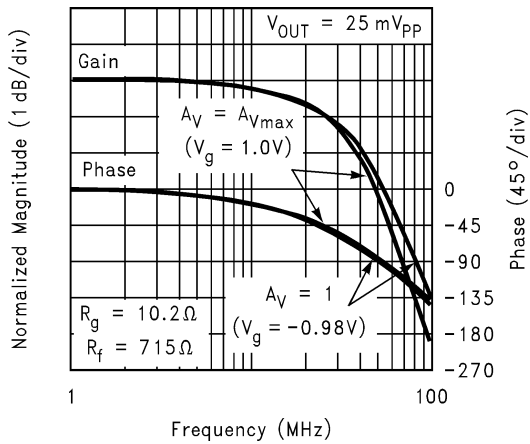

**PSRR and CMRR (input Referred)**

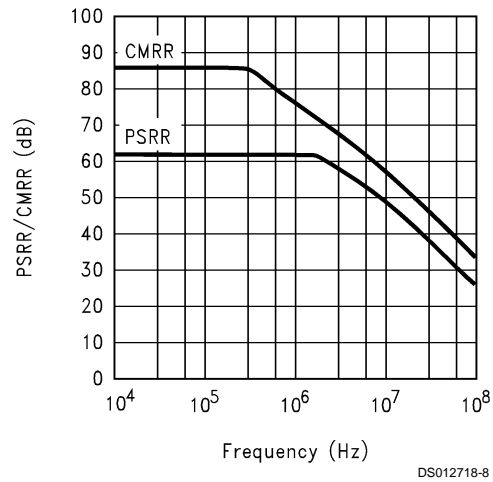

**Feed-Through Isolation**

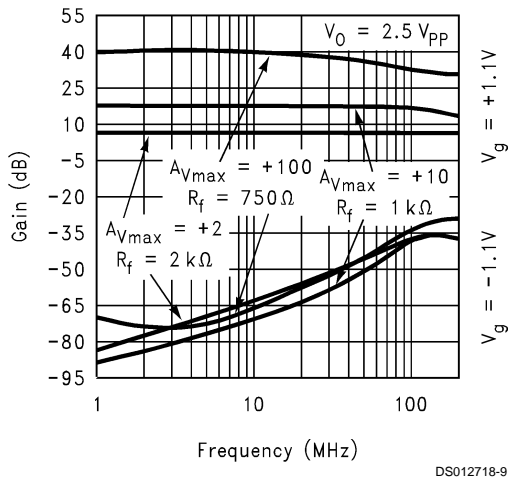

**Gain Flatness & Linear Phase Deviation**

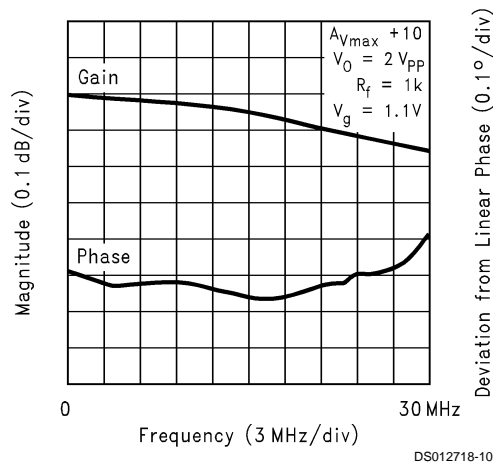

**SGNL vs.  $V_g$ , Gain**

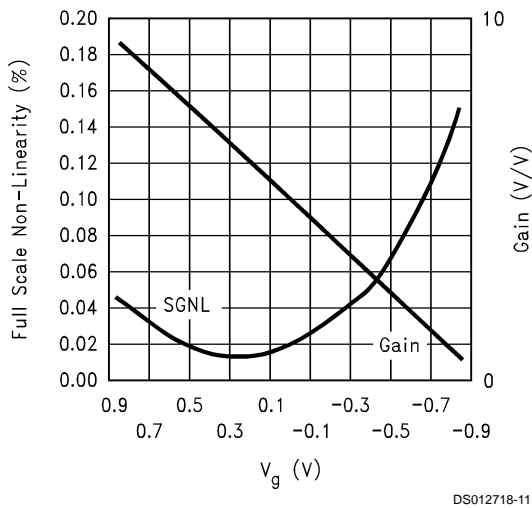

**Large Signal Frequency Response**

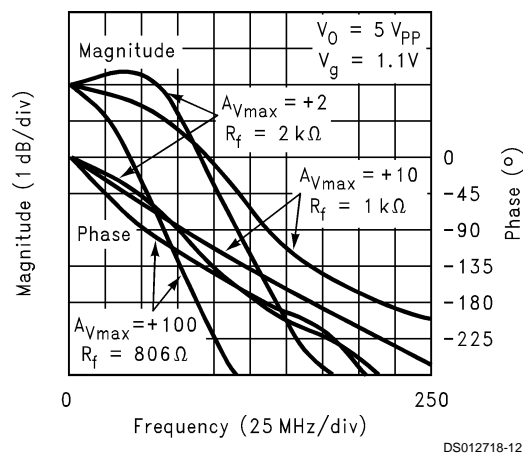



# Typical Performance Characteristics (Continued)

**Settling Time vs. Gain**

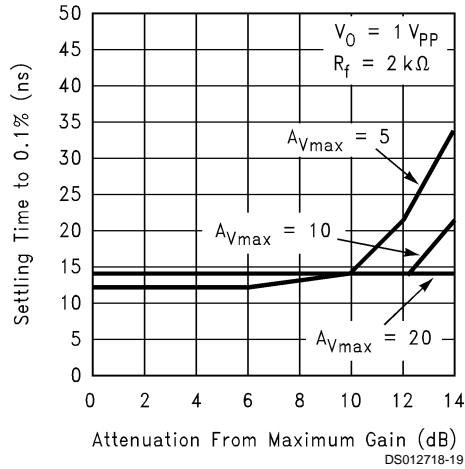

**Differential Gain & Phase**

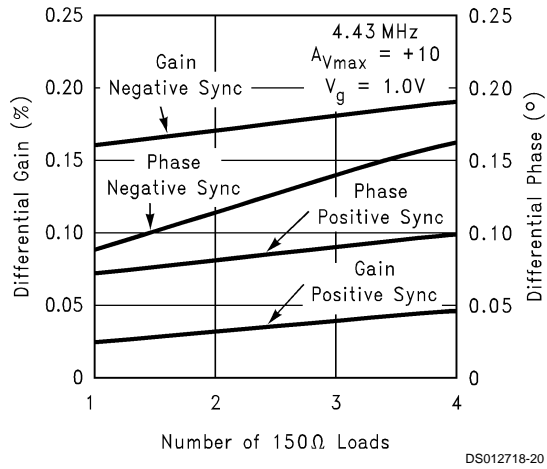

**Differential Gain & Phase**

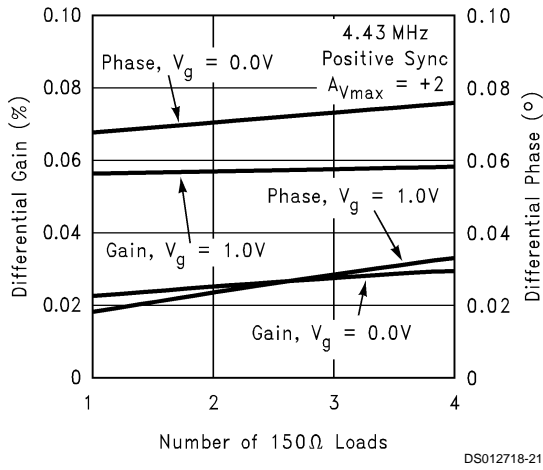

**Input Referred Voltage Noise vs.  $A_{Vmax}$**

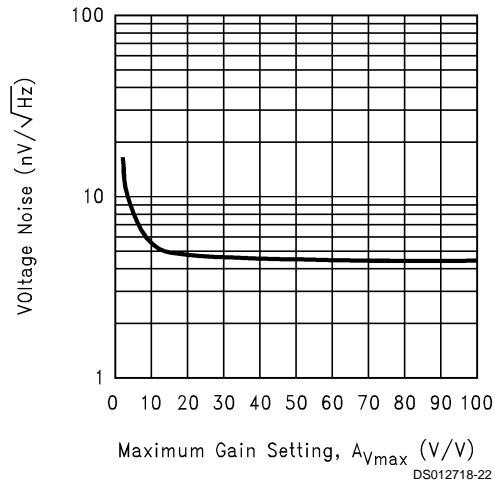

**2nd Harmonic Distortion vs.  $P_{OUT}$**

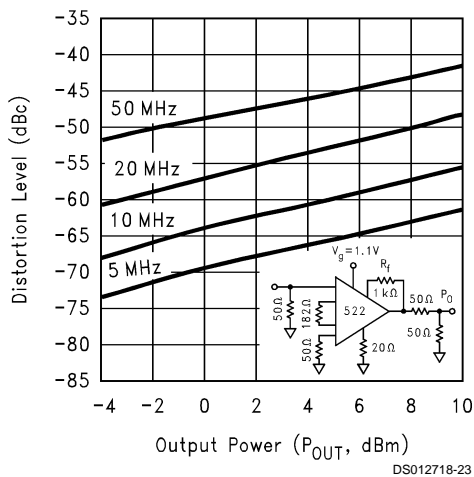

**3rd Harmonic Distortion vs.  $P_{OUT}$**

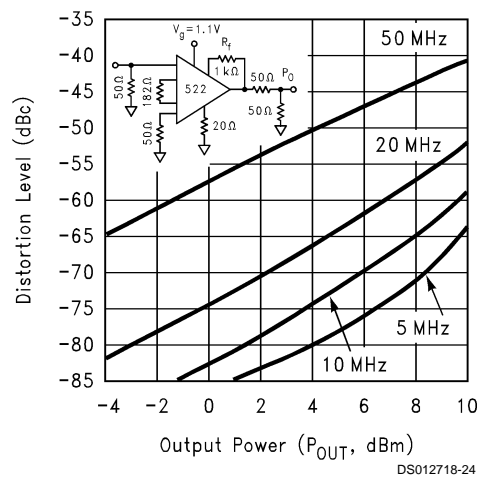



## Typical Performance Characteristics (Continued)

### -1dB Compression at Maximum Gain

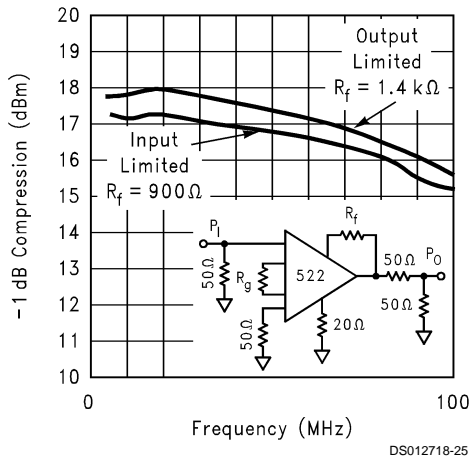

## Application Division

### Theory of Operation

The CLC522 is a linear wideband variable gain amplifier as illustrated in *Figure 1*. A voltage input signal may be applied differentially between the two inputs (+V<sub>IN</sub>, -V<sub>IN</sub>), or single-endedly by grounding one of the unused inputs.

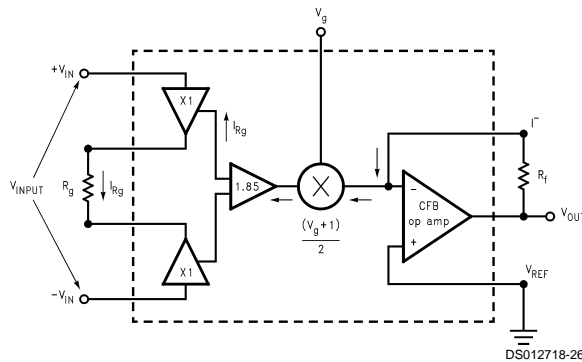

FIGURE 1.

The CLC522 input buffers convert the input voltage to a current ( $I_{Rg}$ ) that is a function of the differential input voltage ( $V_{INPUT} = +V_{IN} - V_{IN}$ ) and the value of the gain-setting resistor ( $R_g$ ). This current ( $I_{Rg}$ ) is then mirrored to a gain stage with a current gain of 1.85. The voltage controlled two-quadrant multiplier attenuates this current which is then converted to a voltage via the output amplifier. This output amplifier is a current-feedback op amp configured as a transimpedance amplifier. Its transimpedance gain is the feedback resistor ( $R_f$ ). The input signal, output, and gain control are all voltages. The output voltage can easily be calculated as seen in Eq. 1.

$$V_{OUT} = I_{Rg} \cdot 1.85 \cdot \left[ \frac{V_g + 1}{2} \right] \cdot R_f \quad (1)$$

$$\text{SINCE } I_{Rg} = \frac{V_{INPUT}}{R_g}$$

$$A_V = 1.85 \cdot \frac{R_f}{R_g} \cdot \left[ \frac{V_g + 1}{2} \right] \quad (2)$$

The gain of the CLC522 is therefore a function of three external variables;  $R_g$ ,  $R_f$  and  $V_g$  as expressed in Eq. 2. The gain control voltage ( $V$ ) has an ideal input range of  $-1V \leq V_g \leq +1V$ . At  $V_g = +1V$ , the gain of the CLC522 is at its maximum as expressed in Eq. 3.

$$A_{V_{max}} = 1.85 \frac{R_f}{R_g} \quad (3)$$

Notice also that Eq. 3 holds for both differential and single-ended operation.

### Choosing $R_f$ and $R_g$

$R_g$  is calculated from Equation 4.  $V_{input_{max}}$  is the maximum peak

$$R_g = \frac{V_{input_{max}}}{I_{Rg_{max}}} \quad (4)$$

input voltage ( $V_{pk}$ ) determined by the application.  $I_{Rg_{max}}$  is the maximum allowable current through  $R_g$  and is typically 1.8mA. Once  $A_{V_{max}}$  is determined from the minimum input and desired output voltages,  $R_f$  is then determined using Eq. 5. These values of  $R_f$  and  $R_g$  are

$$R_f = \frac{1}{1.85} \cdot R_g \cdot A_{V_{max}} \quad (5)$$

the minimum possible values that meet the input voltage and maximum gain constraints. Scaling the resistor values will decrease bandwidth and improve stability.

## Application Division (Continued)

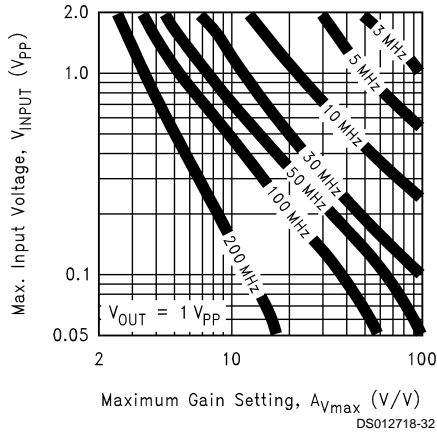

FIGURE 2. Bandwidth vs.  $V_{inpp}$  vs.  $A_{vmax}$

Figure 2 illustrates the resulting CLC522 bandwidths as a function of the maximum and minimum input voltages when  $V_{out}$  is held constant at  $1V_{pp}$ .

### Adjusting Offsets

Treating the offsets introduced by the input and output stages of the CLC522 is easily accomplished with a two step process. The offset voltage of the output stage is treated by first applying  $-1.1$ Volts on  $V_g$ , which effectively isolates the input stage and multiplier core from the output stage.

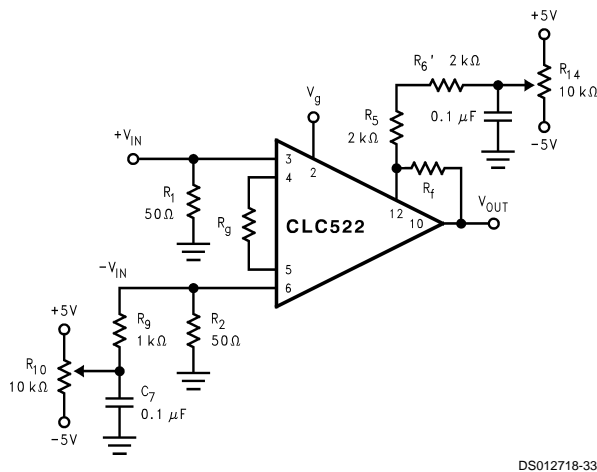

FIGURE 3.

As illustrated in Figure 3, the trip pot located at R14 on the CLC522 Evaluation Board should then be adjusted in order to null the offset voltage seen at the CLC522's output (pin 10). Once this is accomplished, the offset errors introduced by the input stage and multiplier core can then be treated. The second step requires the absence of an input signal and matched source impedances on the two input pins in order to cancel the bias current errors. This done then  $+1.1$ Volts should be applied to  $V_g$  and the trip pot located at R10 adjusted in order to null the offset voltage seen at the CLC522's output. If a more limited gain range is anticipated, the above adjustments should be made at these operating points.

### Gain Errors

The CLC522's gain equation as theoretically expressed in Eq. 2 must include the device's error terms in order to yield

the actual gain equation. Each of the gain error terms are specified in the Electrical Characteristics table and are defined below and illustrated in Figure 4.

**GACCU** : error of  $A_{vmax}$ , expressed as  $\pm$ dB.

**GCNL** : deviation from theoretical expressed as  $\pm$

$V_{ghigh}$  : voltage on  $V_g$  producing  $A_{vmax}$ .

$V_{glow}$  : voltage on  $V_g$  producing  $A_{vmin} = 0V/V$ .

$\Delta V_{ghigh}, \Delta V_{glow}$  : error of  $V_{ghigh}, V_{glow}$  expressed as  $\pm$ mV.

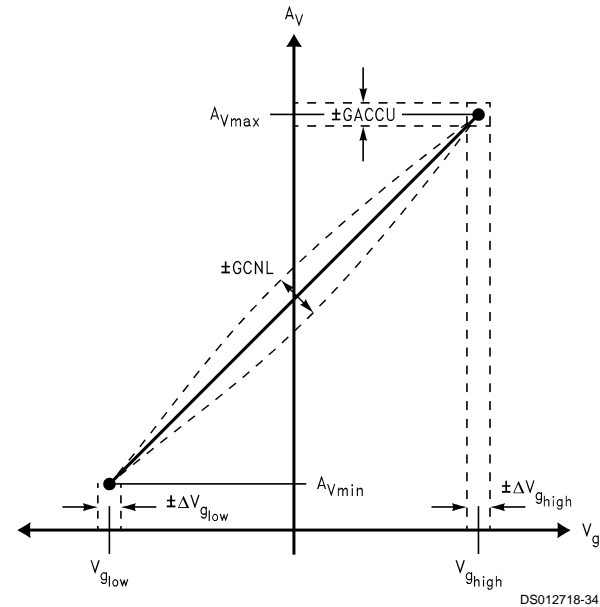

FIGURE 4.

Combining these error terms with Eq. 2 gives the "gain envelope" equation and is expressed in Eq. 7. From the Electrical Characteristics table, the nominal endpoint values of  $V_g$  are:  $V_{ghigh} = 990mV$  and  $V_{glow} = -975mV$ .

$$A_v = A_{vmax} \left[ \frac{+GACCU}{10} \frac{20}{20} \left[ \frac{V_g - V_{glow} \pm \Delta V_{glow}}{V_{ghigh} \pm \Delta V_{ghigh} - V_{glow} \pm \Delta V_{glow}} \right] \pm (1 - V_g^2) GCNL \right] \quad (6)$$

### Signal-Channel Nonlinearity

Signal-channel nonlinearity, SGNL, also known as integral endpoint linearity, measures the non-linearity of an amplifier's voltage transfer function. The CLC522's SGNL, as it is specified in the Electrical Characteristics table, is measured while the gain is set at its maximum (i.e.  $V_g = +1.1V$ ). The Typical Performance Characteristics plot labeled "SGNL & Gain vs  $V_g$ " illustrates the CLC522's SGNL as  $V_g$  is swept through its full range. As can be seen in this plot, when the gain is reduced from  $A_{vmax}$ , SGNL improves to  $<0.02\%$  ( $-74dB$ ) at  $V_g = 0$  and then degrades somewhat at the lowest gains.

### Noise

Figure 5 describes the CLC522's input-referred spot noise density as a function of  $A_{vmax}$ . The plot includes all the noise contributing terms. At  $A_{vmax} = 10V/V$ , the CLC522 has a typical input referred spot noise density ( $e_{ni}$ ) of  $5.8nV/\sqrt{Hz}$ . The input RMS voltage noise can be determined from the following single-pole model:

## Application Division (Continued)

$$V_{RMS} = e_{in} \cdot \sqrt{1.57 \cdot (-3dB \text{ bandwidth})} \quad (7)$$

Further discussion and plots of noise and the noise model is provided in Application Note OA-23. National also provides SPICE models that model internal noise and other parameters for a typical part.

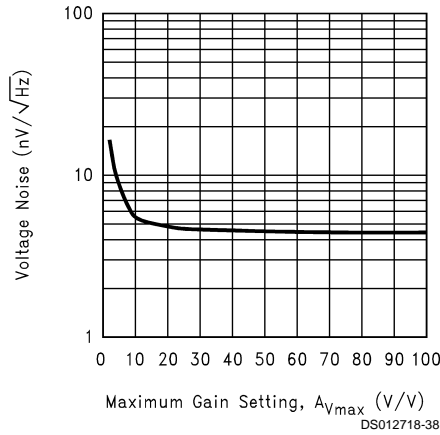

FIGURE 5. Input referred Voltage Noise vs.  $A_{Vmax}$

### Circuit Layout Considerations

Please refer to the CLC522 Evaluation Board literature for precise layout guidelines. Good high-frequency operation requires all of the de-coupling capacitors shown in to be placed as close as possible to the power supply pins in order to insure a proper high-frequency low-impedance bypass.

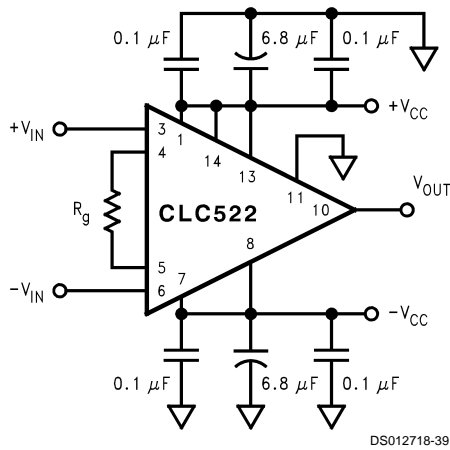
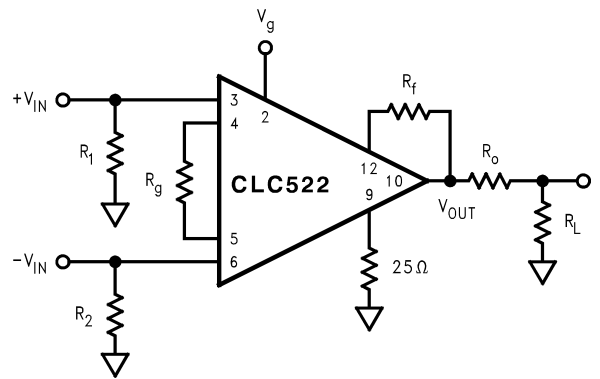

FIGURE 6.

Adequate ground plane and low-inductive power returns are also required of the layout. Minimizing the parasitic capacitances at pins 3, 4, 5, 6, 9, 10 and 12 as shown in Figure 7 will assure best high frequency performance.



DS012718-40

FIGURE 7.

Vref (pin 9) to ground should include a small resistor value of 25 ohms or greater to buffer the internal voltage follower. The parasitic inductance of component leads or traces to pins 4, 5 and 9 should also be kept to a minimum. Parasitic or load capacitance,  $C_L$ , on the output (pin 10) degrades phase margin and can lead to frequency response peaking or circuit oscillation. This should be treated with a small series resistor between output (pin 10) and  $C_L$  (see the plot "Settling Time vs. Capacitive Load" for a recommended series resistance).

Component parasitics also influence high frequency results, therefore it is recommended to use metal film resistors such as RN55D or leadless components such as surface mount devices. High profile sockets are not recommended. If socketing is necessary, it is recommended to use low impedance flush mount connector jacks such as Cambion (P/N 450-2598).

### Application Circuits

#### Four-Quadrant Multiplier

Applications requiring multiplication, squaring or other non-linear functions can be implemented with four-quadrant multipliers. The CLC522 implements a four-quadrant multiplier as illustrated in Figure 8.

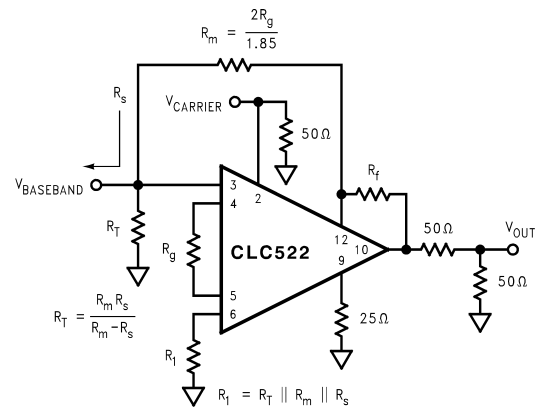

DS012718-41

FIGURE 8.

## Application Division (Continued)

### Frequency Shaping

Frequency shaping the bandwidth extension of the CLC522 can be accomplished using parallel networks connected across the  $R_g$  ports. The network shown in the *Figure 9* schematic will effectively extend the CLC522's bandwidth.

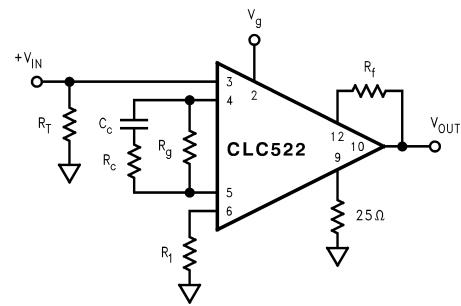

DS012718-42

FIGURE 9.

### 2nd Order Tuneable Bandpass Filter

The CLC522 Variable-Gain Amplifier placed into feedback loops provide signal processing functions such as 2nd order tuneable bandpass filters. The center frequency of the 2nd order bandpass illustrated on the front page is adjusted through the use of the CLC522's gain-control voltage,  $V_g$ . The integrators implemented with two CLC420s, provide the coefficients for the transfer function.

**Physical Dimensions** inches (millimeters) unless otherwise noted

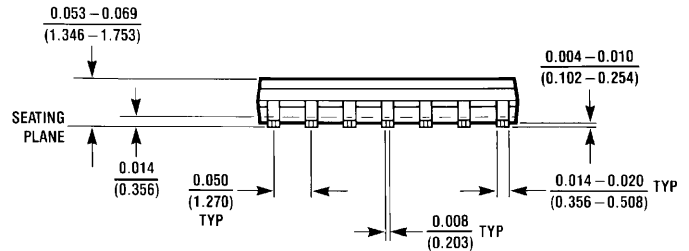
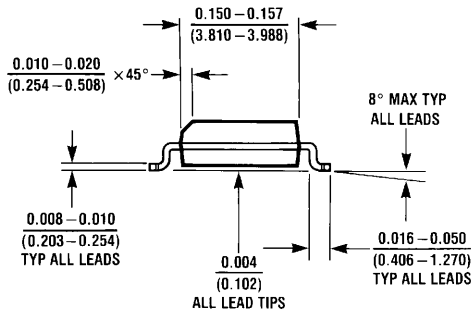
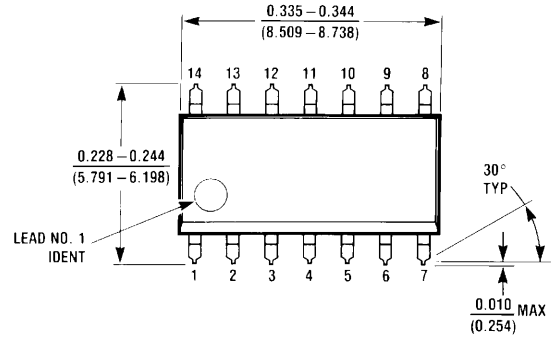

M14A (REV H)

**14-Pin SOIC  
NS Package Number M14A**

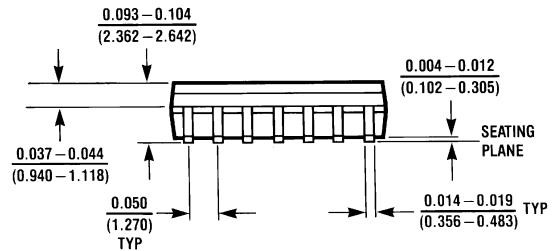
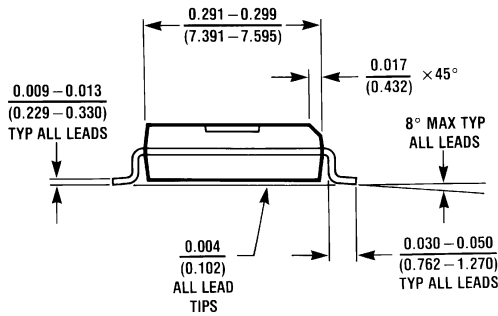
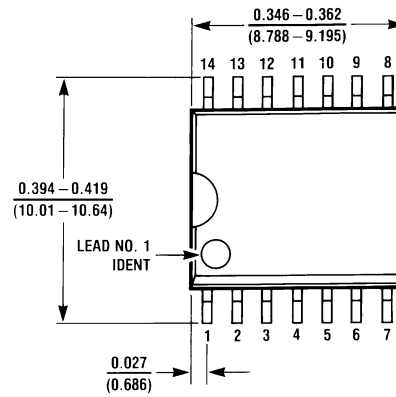

M14B (REV D)

**14-Pin SOIC  
NS Package Number M14B**

**Physical Dimensions** inches (millimeters) unless otherwise noted (Continued)

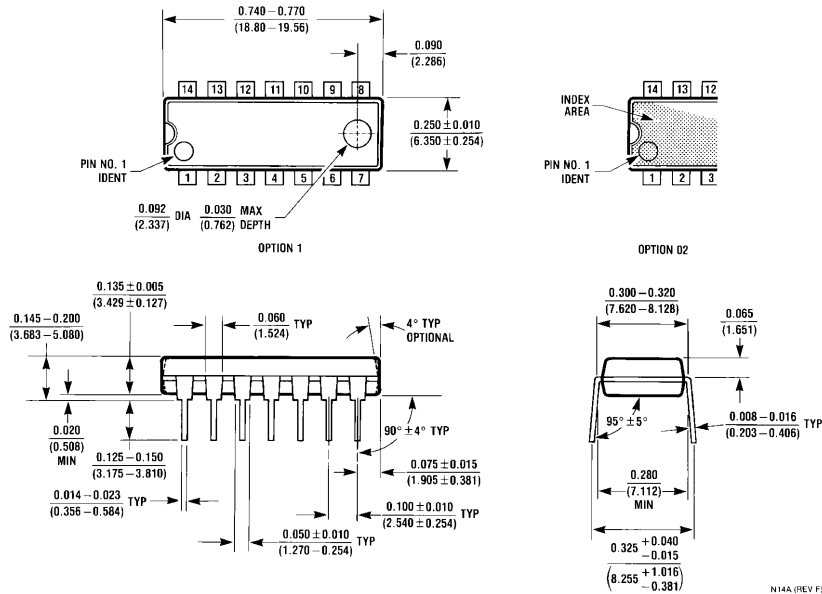

**14-Pin MDIP  
NS Package Number N14A**

**LIFE SUPPORT POLICY**

NATIONAL'S PRODUCTS ARE NOT AUTHORIZED FOR USE AS CRITICAL COMPONENTS IN LIFE SUPPORT DEVICES OR SYSTEMS WITHOUT THE EXPRESS WRITTEN APPROVAL OF THE PRESIDENT AND GENERAL COUNSEL OF NATIONAL SEMICONDUCTOR CORPORATION. As used herein:

1. Life support devices or systems are devices or systems which, (a) are intended for surgical implant into the body, or (b) support or sustain life, and whose failure to perform when properly used in accordance with instructions for use provided in the labeling, can be reasonably expected to result in a significant injury to the user.
2. A critical component is any component of a life support device or system whose failure to perform can be reasonably expected to cause the failure of the life support device or system, or to affect its safety or effectiveness.



**National Semiconductor Corporation**  
Americas  
Tel: 1-800-272-9959  
Fax: 1-800-737-7018  
Email: support@nsc.com  
www.national.com

**National Semiconductor Europe**  
Fax: +49 (0) 180-530 85 86  
Email: europe.support@nsc.com  
Deutsch Tel: +49 (0) 69 9508 6208  
English Tel: +44 (0) 870 24 0 2171  
Français Tel: +33 (0) 1 41 91 8790

**National Semiconductor Asia Pacific Customer Response Group**  
Tel: 65-2544466  
Fax: 65-2504466  
Email: ap.support@nsc.com

**National Semiconductor Japan Ltd.**  
Tel: 81-3-5639-7560  
Fax: 81-3-5639-7507

## IMPORTANT NOTICE

Texas Instruments Incorporated and its subsidiaries (TI) reserve the right to make corrections, modifications, enhancements, improvements, and other changes to its products and services at any time and to discontinue any product or service without notice. Customers should obtain the latest relevant information before placing orders and should verify that such information is current and complete. All products are sold subject to TI's terms and conditions of sale supplied at the time of order acknowledgment.

TI warrants performance of its hardware products to the specifications applicable at the time of sale in accordance with TI's standard warranty. Testing and other quality control techniques are used to the extent TI deems necessary to support this warranty. Except where mandated by government requirements, testing of all parameters of each product is not necessarily performed.

TI assumes no liability for applications assistance or customer product design. Customers are responsible for their products and applications using TI components. To minimize the risks associated with customer products and applications, customers should provide adequate design and operating safeguards.

TI does not warrant or represent that any license, either express or implied, is granted under any TI patent right, copyright, mask work right, or other TI intellectual property right relating to any combination, machine, or process in which TI products or services are used. Information published by TI regarding third-party products or services does not constitute a license from TI to use such products or services or a warranty or endorsement thereof. Use of such information may require a license from a third party under the patents or other intellectual property of the third party, or a license from TI under the patents or other intellectual property of TI.

Reproduction of TI information in TI data books or data sheets is permissible only if reproduction is without alteration and is accompanied by all associated warranties, conditions, limitations, and notices. Reproduction of this information with alteration is an unfair and deceptive business practice. TI is not responsible or liable for such altered documentation. Information of third parties may be subject to additional restrictions.

Resale of TI products or services with statements different from or beyond the parameters stated by TI for that product or service voids all express and any implied warranties for the associated TI product or service and is an unfair and deceptive business practice. TI is not responsible or liable for any such statements.

TI products are not authorized for use in safety-critical applications (such as life support) where a failure of the TI product would reasonably be expected to cause severe personal injury or death, unless officers of the parties have executed an agreement specifically governing such use. Buyers represent that they have all necessary expertise in the safety and regulatory ramifications of their applications, and acknowledge and agree that they are solely responsible for all legal, regulatory and safety-related requirements concerning their products and any use of TI products in such safety-critical applications, notwithstanding any applications-related information or support that may be provided by TI. Further, Buyers must fully indemnify TI and its representatives against any damages arising out of the use of TI products in such safety-critical applications.

TI products are neither designed nor intended for use in military/aerospace applications or environments unless the TI products are specifically designated by TI as military-grade or "enhanced plastic." Only products designated by TI as military-grade meet military specifications. Buyers acknowledge and agree that any such use of TI products which TI has not designated as military-grade is solely at the Buyer's risk, and that they are solely responsible for compliance with all legal and regulatory requirements in connection with such use.

TI products are neither designed nor intended for use in automotive applications or environments unless the specific TI products are designated by TI as compliant with ISO/TS 16949 requirements. Buyers acknowledge and agree that, if they use any non-designated products in automotive applications, TI will not be responsible for any failure to meet such requirements.

Following are URLs where you can obtain information on other Texas Instruments products and application solutions:

### Products

Audio	<a href="http://www.ti.com/audio">www.ti.com/audio</a>
Amplifiers	<a href="http://amplifier.ti.com">amplifier.ti.com</a>
Data Converters	<a href="http://dataconverter.ti.com">dataconverter.ti.com</a>
DLP® Products	<a href="http://www.dlp.com">www.dlp.com</a>
DSP	<a href="http://dsp.ti.com">dsp.ti.com</a>
Clocks and Timers	<a href="http://www.ti.com/clocks">www.ti.com/clocks</a>
Interface	<a href="http://interface.ti.com">interface.ti.com</a>
Logic	<a href="http://logic.ti.com">logic.ti.com</a>
Power Mgmt	<a href="http://power.ti.com">power.ti.com</a>
Microcontrollers	<a href="http://microcontroller.ti.com">microcontroller.ti.com</a>
RFID	<a href="http://www.ti-rfid.com">www.ti-rfid.com</a>
OMAP Mobile Processors	<a href="http://www.ti.com/omap">www.ti.com/omap</a>
Wireless Connectivity	<a href="http://www.ti.com/wirelessconnectivity">www.ti.com/wirelessconnectivity</a>

### Applications

Communications and Telecom	<a href="http://www.ti.com/communications">www.ti.com/communications</a>
Computers and Peripherals	<a href="http://www.ti.com/computers">www.ti.com/computers</a>
Consumer Electronics	<a href="http://www.ti.com/consumer-apps">www.ti.com/consumer-apps</a>
Energy and Lighting	<a href="http://www.ti.com/energy">www.ti.com/energy</a>
Industrial	<a href="http://www.ti.com/industrial">www.ti.com/industrial</a>
Medical	<a href="http://www.ti.com/medical">www.ti.com/medical</a>
Security	<a href="http://www.ti.com/security">www.ti.com/security</a>
Space, Avionics and Defense	<a href="http://www.ti.com/space-avionics-defense">www.ti.com/space-avionics-defense</a>
Transportation and Automotive	<a href="http://www.ti.com/automotive">www.ti.com/automotive</a>
Video and Imaging	<a href="http://www.ti.com/video">www.ti.com/video</a>

TI E2E Community Home Page

[e2e.ti.com](http://e2e.ti.com)

Mailing Address: Texas Instruments, Post Office Box 655303, Dallas, Texas 75265  
Copyright © 2011, Texas Instruments Incorporated