

2-phase motor driver for VCR cylinder motors

BA6827FS

The BA6827FS is a direct-drive motor driver suitable for 2-phase, full-wave linear motors. It contains Hall amplifier control circuits, drivers, FG and PG signal amplifiers, and hysteresis amplifiers.

●Applications
VCR cylinder motors

- Features
- 1) Linear drive system provides low switching noise.
 - 2) Output current can be controlled with current input and voltage input pins.
 - 3) Two amplifiers and two hysteresis amplifiers are built in.
 - 4) Constant voltage pin for Hall device power supply.
 - 5) High ratio of output current over control current. (4000 typically)
 - 6) Available in a compact surface-mount package.

●Block diagram

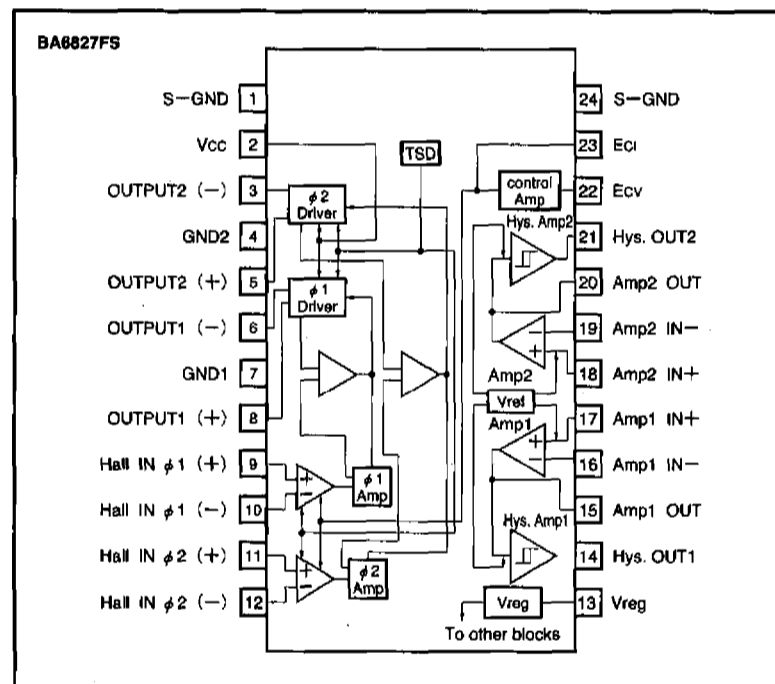

● Absolute maximum ratings (Ta=25°C)

Parameter	Symbol	Limits	Unit
Power supply voltage	V _{CC}	24	V
Power dissipation	P _d	1000*1	mW
Operating temperature	T _{opr}	-25~75	°C
Storage temperature	T _{stg}	-55~150	°C
Output current	I _{OMax}	1200*2	mA
Input current	I _{ECIMax}	5	mA

* 1 Mounted on a glass epoxy PCB (90 X 50 X 1.6 mm).

Reduce power by 8 mW for each degree above 25°C.

* 2 Should not exceed P_d- or ASO-value (for the current of one phase).

● Recommended operating conditions

Parameter	Symbol	Limits	Unit
Operating power supply voltage	V _{CC}	8.0~20.0	V

● Electrical characteristics (Unless otherwise noted, Ta=25°C, V_{CC}=12V)

Parameter	Symbol	Min.	Typ.	Max.	Unit	Conditions
Circuit current	I _{CC}	—	8.5	13.0	mA	
Constant output voltage	V _{reg}	4.6	5.0	5.4	V	
~MDA~						
Hall device minimum input level	V _{INH}	50	—	—	mV _{P-P}	
Hall device input bias current	I _{BH}	—	0.25	2.0	μA	I _{cont} =100 μA
HIGH level output saturation voltage	V _{OH}	10.45	10.79	—	V	I _{OUT} =800mA
LOW level output saturation voltage	V _{OL}	—	1.33	2.16	V	I _{OUT} =800mA
~ECV (voltage regulation) ~						
Torque control input voltage	E _{CV}	0	—	V _{reg}	V	
Torque control voltage offset	E _{CVOFFS}	-150	0	150	mV	For 0.48 X V _{reg}
Torque control input current	I _{ECVIN}	—	1.0	6	μA	E _{CV} =2.5V
Output idle current	I _{ECVidle}	—	0	5	mA	E _{CV} =2.0V
I/O gain	G _{ECV}	0.42	0.55	0.68	A/V	Measured at E _{CV} = 2.8 V, 3.3 V; ΔV _{IN} = 100 mV
~E _{CI} (current control) ~						
Ratio of pin-23 current and output current	I _{OUT} / I _{cont}	3000	4000	5000	—	ΔV _{IN} = 100 mV; measured at I _{cont} = 30 μA, 50 μA
Output current differential	ΔI _{OUT}	-30	0	+30	mA	I _{cont} = 30 μA
~Amp1, Amp2~						
-Input current	I _{INA}	—	0.2	2.0	μA	V _{IN} =2.5V
Open loop gain	G _A	65	70	—	dB	f _N =500Hz
DC bias voltage variation	ΔV _{BA}	-10	0	10	%	Variation from 1/2 V _{reg}
HIGH level output voltage	V _{OH A}	V _{reg} -1.48	V _{reg} -1.08	—	V	I _{OH A} =0.5mA
LOW level output voltage	V _{OL A}	—	1.05	1.45	V	I _{OL A} =0.5mA
Input voltage of amplifiers 1 and 2	V _{AB}	1.2	—	4.0	V	
~Hys. Amp1, 2~						
Hysteresis width	V _{hys}	±142	±180	±218	mV	
LOW level output voltage	V _{OL hys}	—	0.12	0.32	V	I _{OL hys A} =2mA
Output pull-up resistance	V _{thys}	7.0	10.0	13.0	kΩ	

○ Not designed for radiation resistance

● Pin description

Pin No.	Pin name	Function
1	S-GND	Signal ground pin
2	Vcc	Power supply pin
3	OUTPUT2(-)	Output pin
4	GND2	OUTPUT2 GND
5	OUTPUT2(+)	Output pin
6	OUTPUT1(-)	Output pin
7	GND1	OUTPUT1 GND
8	OUTPUT1(+)	Output pin
9	Hall IN ϕ_1 (+)	Hall signal input pin
10	Hall IN ϕ_1 (-)	Hall signal input pin
11	Hall IN ϕ_2 (+)	Hall signal input pin
12	Hall IN ϕ_2 (-)	Hall signal input pin
13	Vreg	Constant voltage output pin
14	Hys.out1	Hysteresis amplifier 1 output pin
15	Amp1out	Amplifier 1 output pin; hysteresis amplifier 1 input pin
16	Amp1in-	Amplifier 1 Input pin, inverted
17	Amp1in+	Amplifier 1 Input pin, non-inverted
18	Amp2in+	Amplifier 2 Input pin, non-inverted
19	Amp2in-	Amplifier 2 Input pin, inverted
20	Amp2out	Amplifier 2 output pin; hysteresis amplifier 2 input pin
21	Hys.out2	Hysteresis amplifier 2 output pin
22	Ecv	Output current control pin (voltage control)
23	Eci	Output current control pin (current control)
24	S-GND	Signal ground pin

● Input/output circuits

(1) E_{cv} (22 pin)

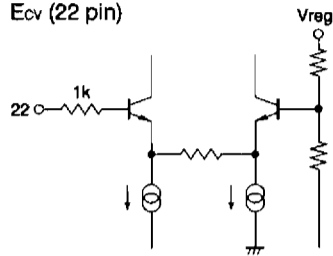

(Resistances, in Ω , are typical values)

Fig.1

(2) Driver output (8, 6, 5, 3 pin)

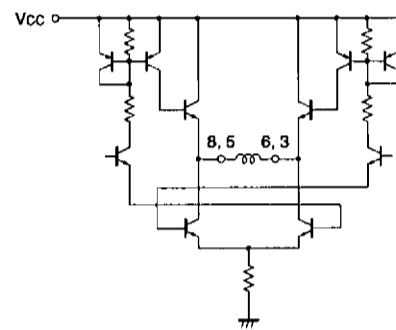

(Resistances, in Ω , are typical values)

Fig.2

(3) Hall input (9, 10, 11, 12 pin) and E_{ci} input

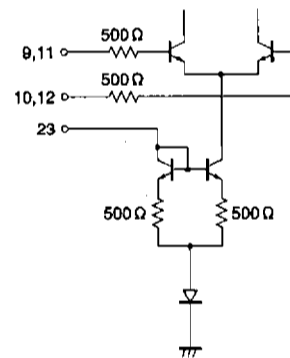

(Resistances, in Ω , are typical values)

Fig.3

(4) I/O of amplifiers 1 and 2

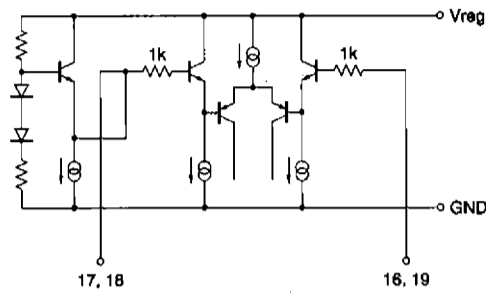

(Resistances, in Ω , are typical values)

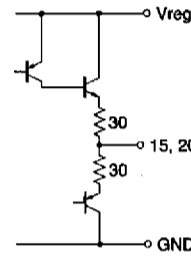

(Resistances, in Ω , are typical values)

Fig.4

(5) I/O of hysteresis amplifier

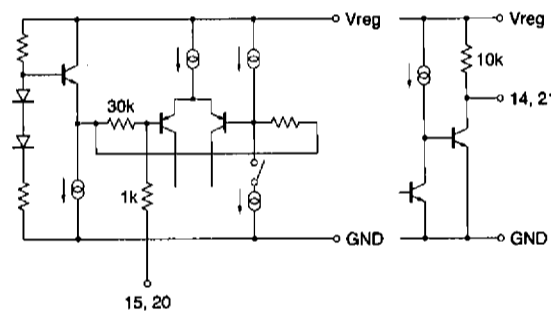

(Resistances, in Ω , are typical values)

Fig.5

* Note that resistance values of the I/O circuits can vary $\pm 30\%$.

● Circuit operation

(1) The signal from the Hall device is amplified by the Hall amplifier and then supplied to the driver circuit. The driver gain, which is constant, is regulated by changing the Hall amplifier gain with the E_{ci} input current or the E_{cv} input voltage (E_{ci} and E_{cv} are output current control pins). The motor rotational speed is sensed by the FG, and the output from which is F/I-converted and supplied to the E_{ci} pin or F/V-converted and supplied to the E_{cv} pin as a feedback signal, so that a constant rotational speed is maintained as follows (Fig. 6) :

- 1) The motor speed decreases.
- 2) The speed control IC outputs a feedback signal.
- 3) The Hall amplifier gain increases.
- 4) The output current increases.
- 5) The motor speed increases.

(2) When the voltage on Hall IN ϕ_1 (+) is higher than the voltage on Hall IN ϕ_1 (-), an output current flows from OUT1 (+) to OUT1 (-). When the voltage on Hall IN ϕ_1 (-) is higher, on the other hand, an output current flows from OUT1 (-) to OUT1 (+).

Similarly, when the voltage on Hall IN ϕ_2 (+) is higher than the voltage on Hall IN ϕ_2 (-), an output current flows from OUT2 (+) to OUT2 (-). When the voltage on Hall IN ϕ_2 (-) is higher, on the other hand, an output current flows from OUT2 (-) to OUT2 (+).

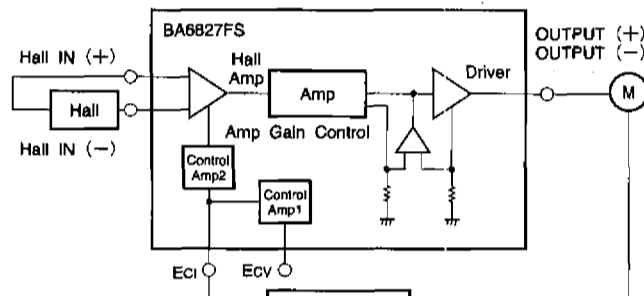

Fig.6

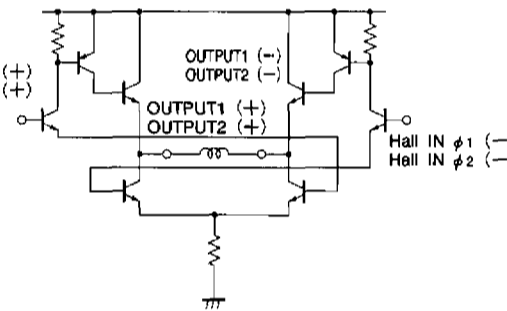

Fig.7

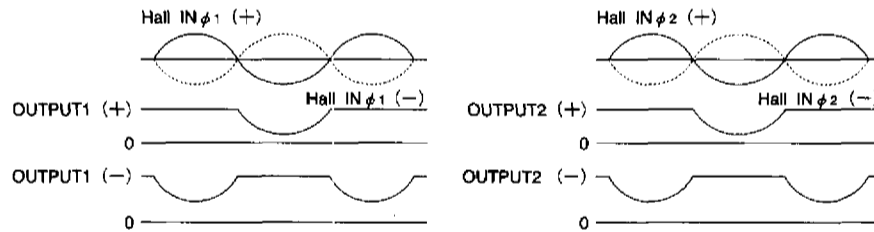

Fig.8

(3) Output waveforms are shown in Fig. 9. Because of the amplifier offset, the output is left OPEN when the output signal switches from positive to negative. The output waveform is determined by the external circuit because the IC impedance increases during this transition period. Since inductive loads are usually provided, a capacitor should be connected to suppress the backlash voltage.

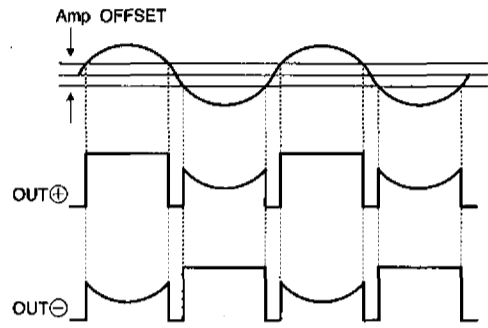

Fig.9

● Operation notes

1. E_{CV} input (22 pin)

The E_{CV} input is plotted against the output current in Fig. 10.

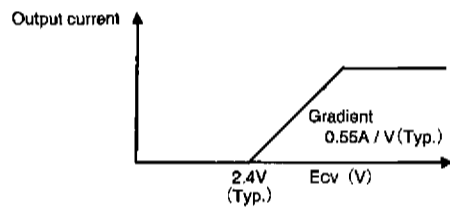

Fig.10

2. Hall input

Hall input signals of 50mV (peak to peak) or greater should be applied between pins 9 and 10 and between pins 11 and 12. The DC input range is 2V to (V_{reg} - 1.5V). There will be no problem if the input is centered around V_{reg}/2.

Because the Hall input impedance is 1MΩ or greater, any type of Hall device can be connected. No current flows when the transistor is off because pins 9 and 10 as well as pins 11 and 12 are differential inputs.

Because the IC is a linear driver, any DC offset in the Hall device will be amplified and appear in the output. Use Hall devices having a minimum offset. Hall devices can be connected in either series or parallel.

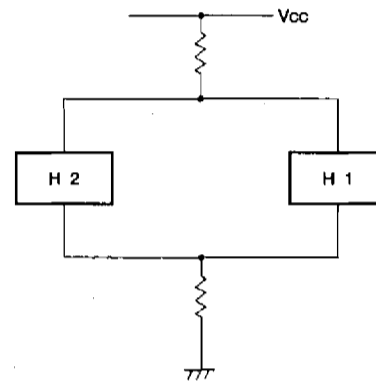

Parallel connection

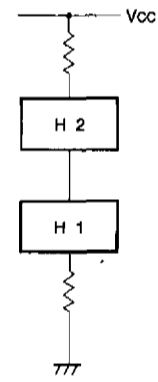

Series connection

Fig.11

● Operation notes

3. E_{ci} input

The E_{ci} input circuit has $2V_f$ and a $500\ \Omega$ resistor connected in series. Current is limited only by the $500\ \Omega$ resistor.

4. Amplifiers 1 and 2

An input range of $0.6V$ to $(V_{cc} - 1.2V)$ is recommended. Unpredictable outputs may occur when the input is outside this range.

5. Hysteresis amplifier

An input range of $0.6V$ to $(V_{cc} - 1.2V)$ is recommended. Unpredictable outputs may occur when the input is outside this range.

6. Thermal shutdown circuit

The circuit puts the driver outputs (pins 3, 5, 6, and 8) to the open state at the temperature of $175^\circ C$ (typical). There is a temperature difference of about $20^\circ C$ between the temperatures at which the circuit is activated and deactivated.

7. Signal ground pin

Pins 1 and 24 are signal ground pins. Be noted that unpredictable outputs may occur if your application causes a large current between pins 1 and 24 through the bonding wire chip.

● Application example

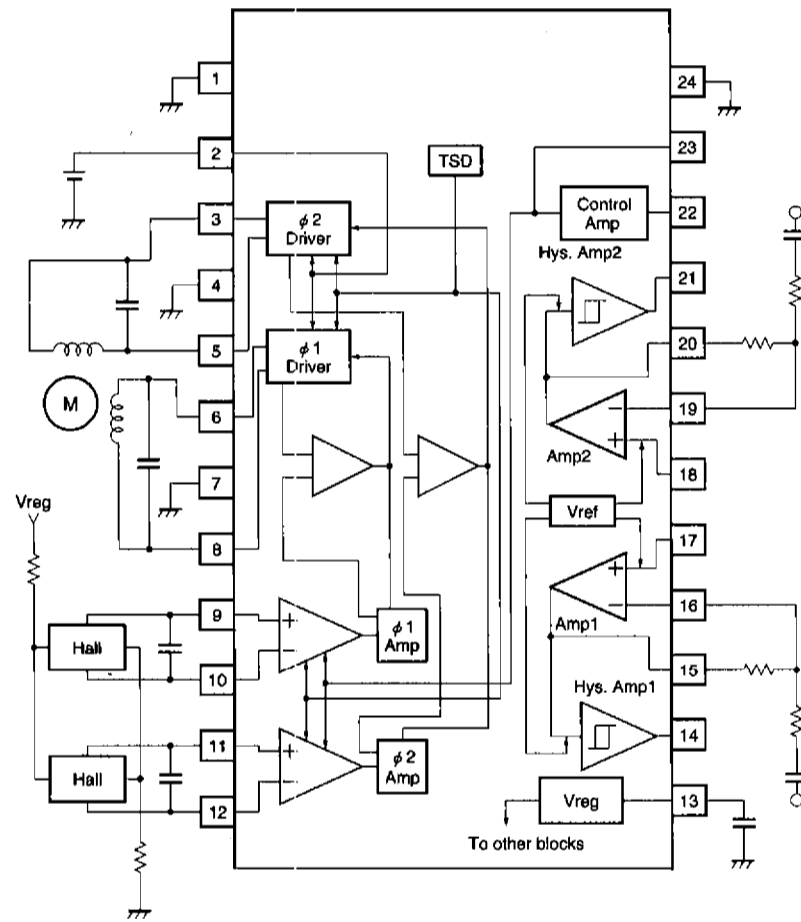

Fig.12

●Electrical characteristic curves

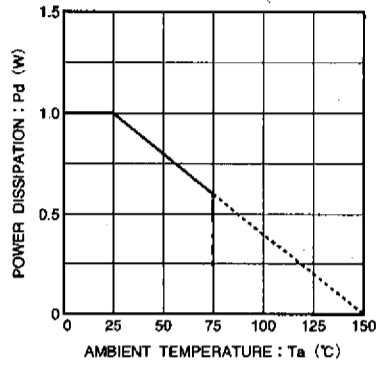

Fig.13 Temperature dependence of power dissipation curve

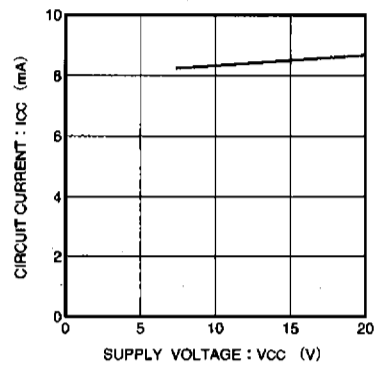

Fig.14 Circuit current vs. supply voltage

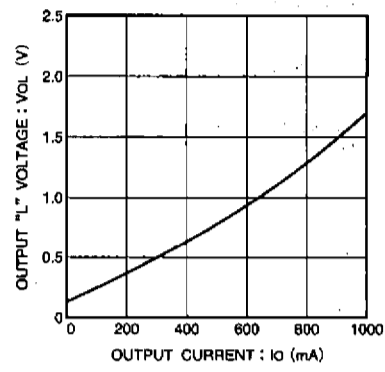

Fig.15 LOW level output voltage vs. output current

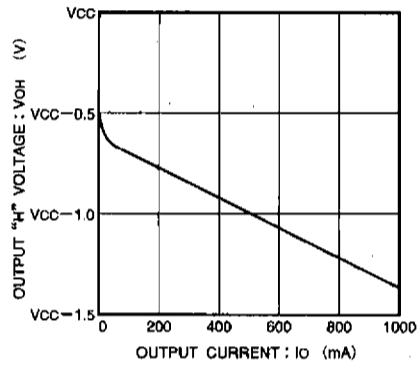

Fig.16 HIGH level output voltage vs. output current

●External dimensions (Units: mm)

