

# Ground isolation amplifier

## BA3121 / BA3121F / BA3121N

The BA3121, BA3121F and BA3121N are ground isolation amplifiers developed for use in car audio applications. These ICs efficiently eliminate problems caused by wiring resistance, and remove noise generated by the electrical devices used in automobiles. The capacitance values of the external capacitors required for the ICs are small to allow compact and reliable set design.

### ●Applications

Car audio systems

### ●Features

- 1) Large capacitors not required
- 2) High common-mode rejection ratio (57dB typ. at f = 1kHz).
- 3) Low noise ( $V_{NO} = 3.5\mu V_{rms}$  Typ.).
- 4) Low distortion (THD = 0.002% Typ.).
- 5) Two channels.

### ●Absolute maximum ratings (Ta = 25°C)

Parameter	Symbol	Limits	Unit
Power supply voltage	Vcc	18	V
Power dissipation	Pd	800 (BA3121)*	mW
		450 (BA3121F)*	
		900 (BA3121N)*	
Operating temperature	Topr	-30~+85	°C
Storage temperature	Tstg	-55~+125	°C

\* Reduced by 8.0mW (BA3121), 4.5mW (BA3121F), and 9.0mW (BA3121N) for each increase in Ta of 1°C over 25°C.

### ●Recommended operating conditions (Ta = 25°C)

Parameter	Symbol	Min.	Typ.	Max.	Unit
Power supply voltage	Vcc	4	12	18	V

● Block diagrams

BA3121 / BA3121F

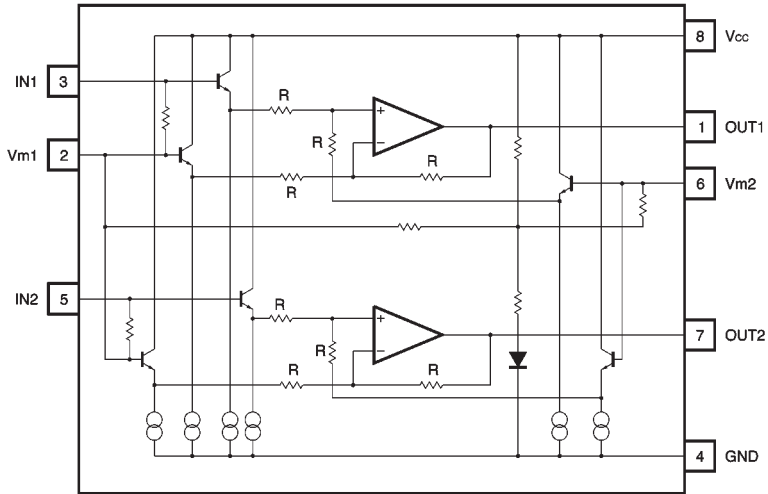

BA3121N

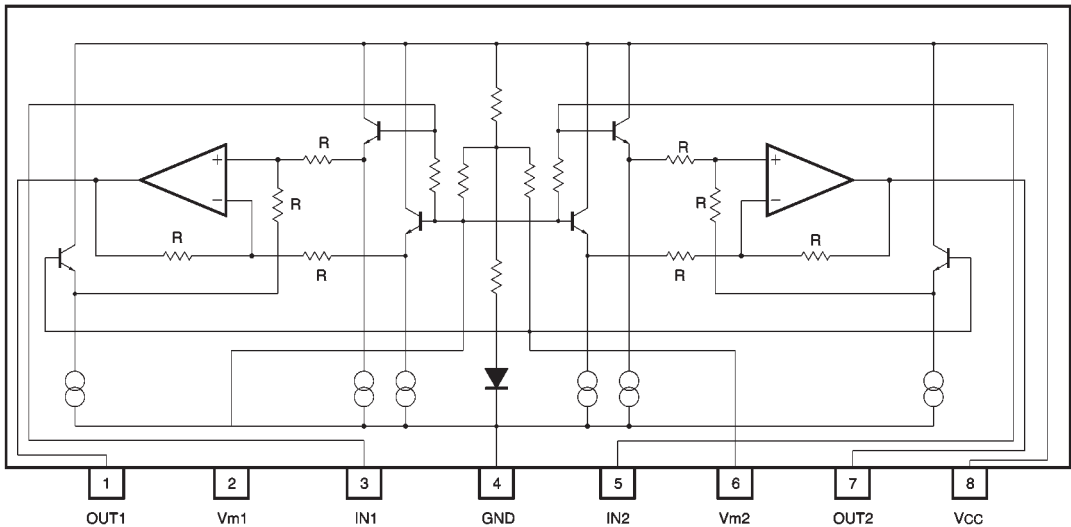

●Electrical characteristics (unless otherwise noted,  $T_a = 25^\circ\text{C}$ ,  $V_{CC} = 12\text{V}$ ,  $f = 1\text{kHz}$ ,  $R_g = 1.8\text{k}\Omega$ )

Parameter	Symbol	Min.	Typ.	Max.	Unit	Conditions
Quiescent current	$I_Q$	5.6	9.0	14.0	mA	$V_{IN}=0V_{rms}$
Output noise voltage	$V_{NO}$	—	3.5	8.0	$\mu V_{rms}$	BPF=20Hz~20kHz
Voltage gain	$G_V$	-1.5	-0.04	1.5	dB	$V_O=-10\text{dBm}$ , $R_g=0\Omega$
Maximum output voltage	$V_{OM}$	1.8	2.0	—	$V_{rms}$	THD=0.1%, $V_{CC}=8\text{V}$
Total harmonic distortion	THD	—	0.002	0.02	%	$V_O=0.7V_{rms}$
Common-mode rejection ratio	CMRR	41	57	—	dB	
Common-mode voltage	$V_{CM}$	2.5	3.75	—	$V_{rms}$	$V_{CC}=8\text{V}$ , CMRR=40dB
Ripple rejection ratio	RR	72	80	—	dB	$f_{RR}=100\text{Hz}$ , $V_{RR}=-10\text{dBm}$ , $R_g=0\Omega$
Channel separation	CS	—	82	—	dB	$V_{IN}=-10\text{dBm}$ , $R_g=1.8\text{k}\Omega/\text{OPEN}$
Slew rate	SR	—	2.0	—	$\text{V}/\mu\text{s}$	
Input resistance	$R_{IN}$	44	55	66	$\text{k}\Omega$	

©Not designed for radiation resistance.

● Measurement circuits

BA3121/BA3121F

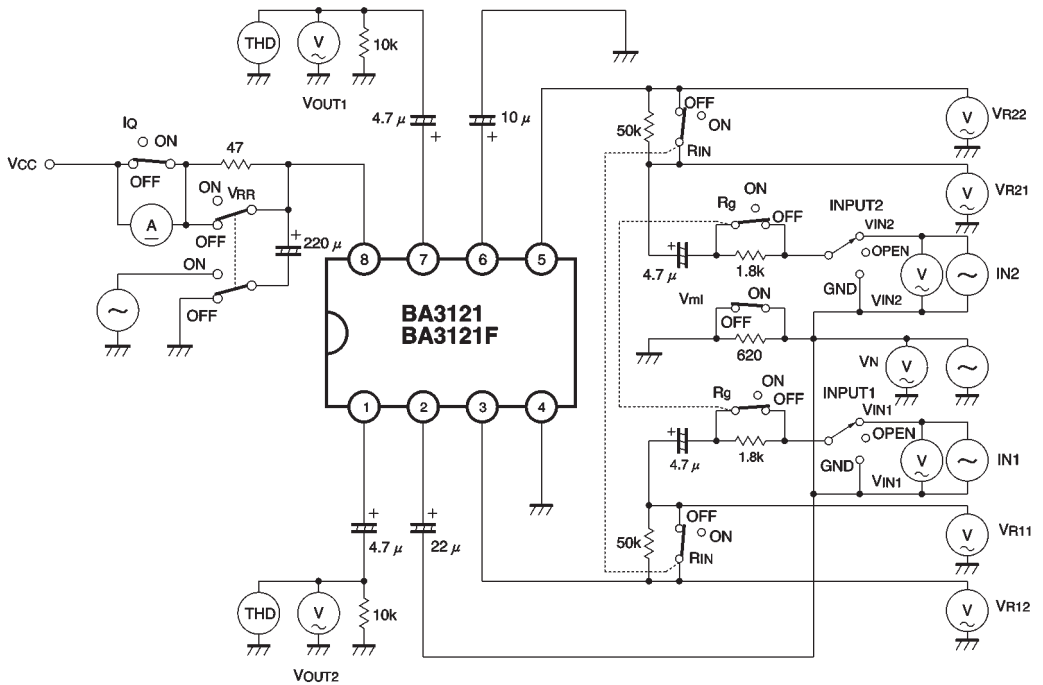
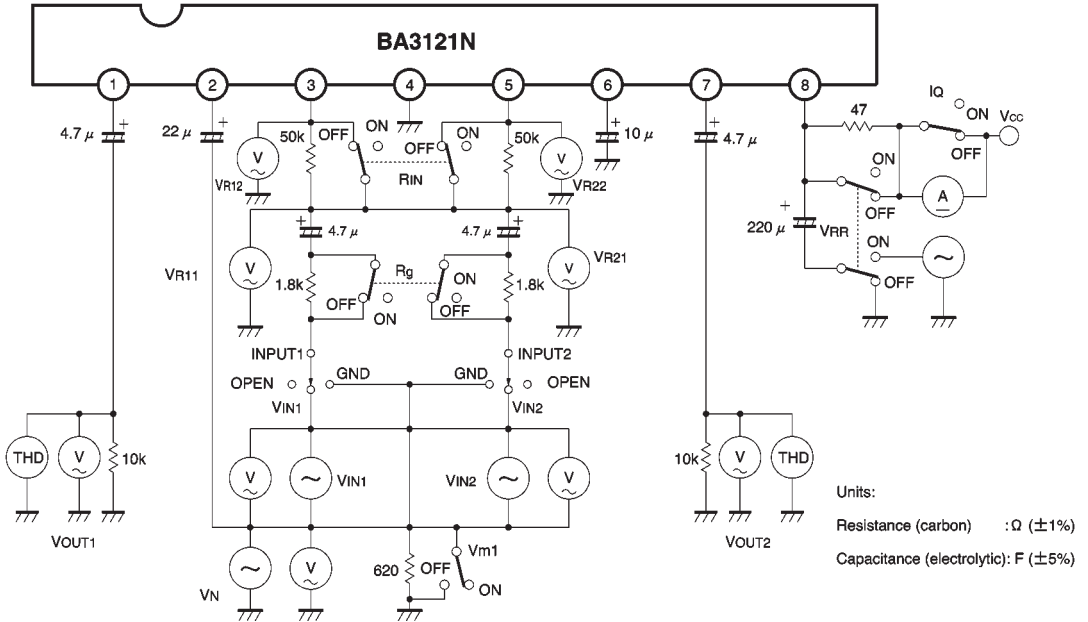

Fig. 1

BA3121N



Units:

Resistance (carbon) : Ω (±1%)

Capacitance (electrolytic): F (±5%)

Fig. 2

● Circuit operation

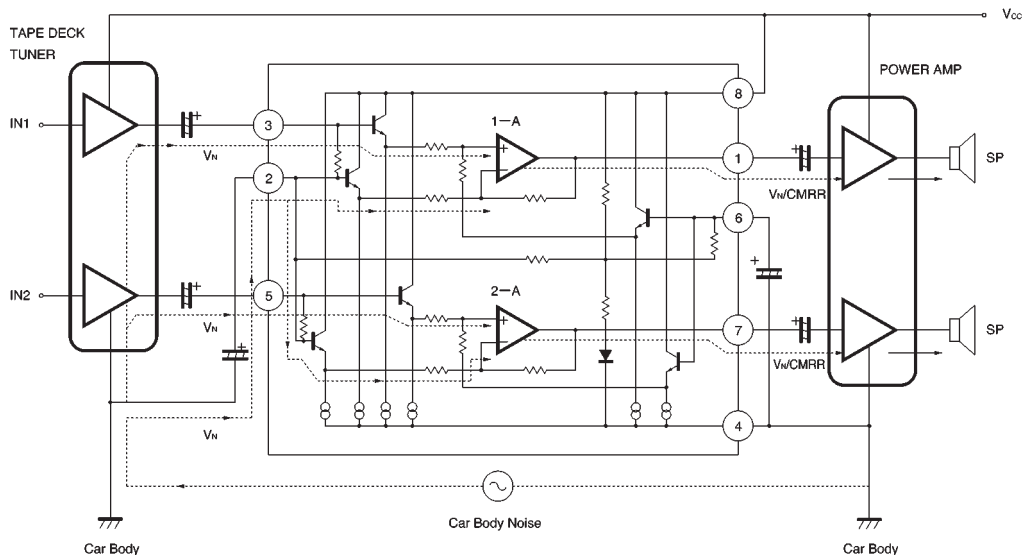

Fig. 3 Flow of noise in car-audio systems

Car-audio systems are earthed to the car body, and for this reason, electrical noise generated by the car electronics can enter the power amplifier input via the chassis, and become audible.

The BA3121 makes use of the common-mode rejection characteristics of an operational amplifier to eliminate this noise. Without the BA3121 noise enters the power amplifier input directly, when used, the CMRR of operational amplifiers 1-A and 2-A eliminates the noise.

Principles of noise elimination:

To obtain the output voltage ( $e_o$ )

$$V_i = \frac{R_4}{(R_3 + R_4)} \cdot e_2 \quad (1)$$

$$e_o = -\frac{R_2}{R_1} e_1 + \frac{R_1 + R_2}{R_1} \cdot V_i \quad (2)$$

From (1) and (2)

$$\begin{aligned} e_o &= -\frac{R_2}{R_1} e_1 + \frac{R_1 + R_2}{R_1} \cdot \frac{R_4}{(R_3 + R_4)} \cdot e_2 \\ &= -\frac{R_2}{R_1} \cdot (e_1 - e_2) + \frac{R_1 R_4 - R_2 R_3}{R_1 (R_3 + R_4)} \cdot e_2 \end{aligned}$$

Ideally, if  $R_1 R_4 = R_2 R_3$ , and  $e_1 = e_2$ , the noise voltage will become zero. However, due to mismatching between the resistors, difference in the noise voltages ( $e_1$  and  $e_2$ ), and tolerances in the operational amplifier, a noise voltage does result.

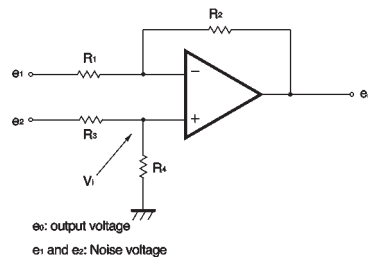

Fig. 4 The principle of noise rejection

With the BA3121, the elimination level of the noise is expressed as:  $CMRR = 20 \log (e_o / e_i)$  ( $e_i = e_1 = e_2$ )  
Therefore,  $CMRR \geq 41 \text{dB}$  can be guaranteed.

● Operation notes

- (1) Maintain a ratio of 2: 1 for the values of the capacitors connected to pin 2 ( $V_{m1}$ ) and pin 6 ( $V_{m2}$ ) to keep the ripple rejection ratio stable. If this ratio is maintained, the ripple rejection ratio will not vary significantly even if the capacitance values are halved.
- (2) If the value of the capacitor connected to pin 2 ( $V_{m1}$ ) in the example is doubled, the bass-region CMRR will be +6dB, and if it is halved, it will be -6dB (see Fig. 16).

●Application example

BA3121/BA3121F

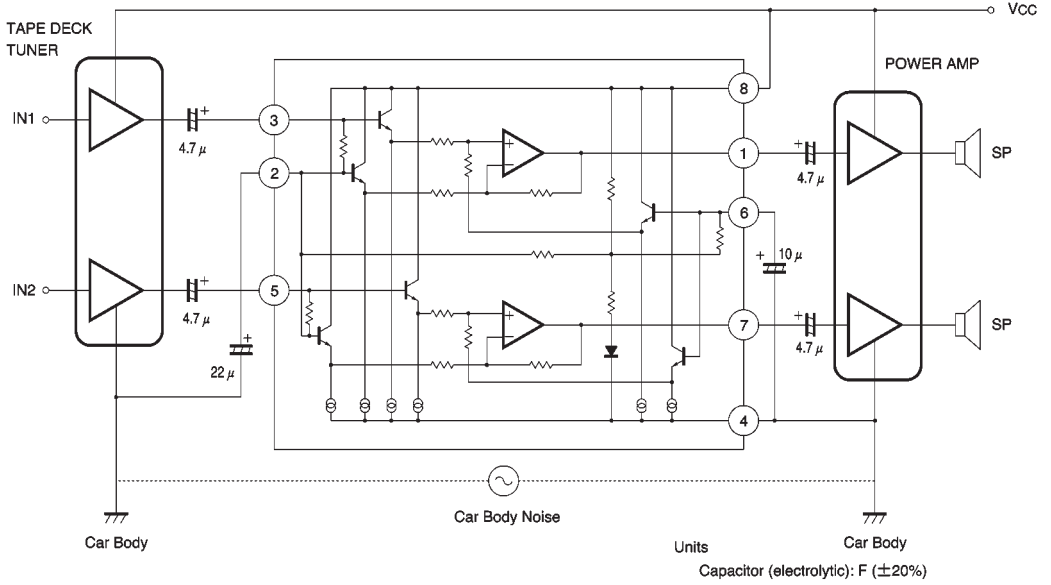

Fig. 5

BA3121N

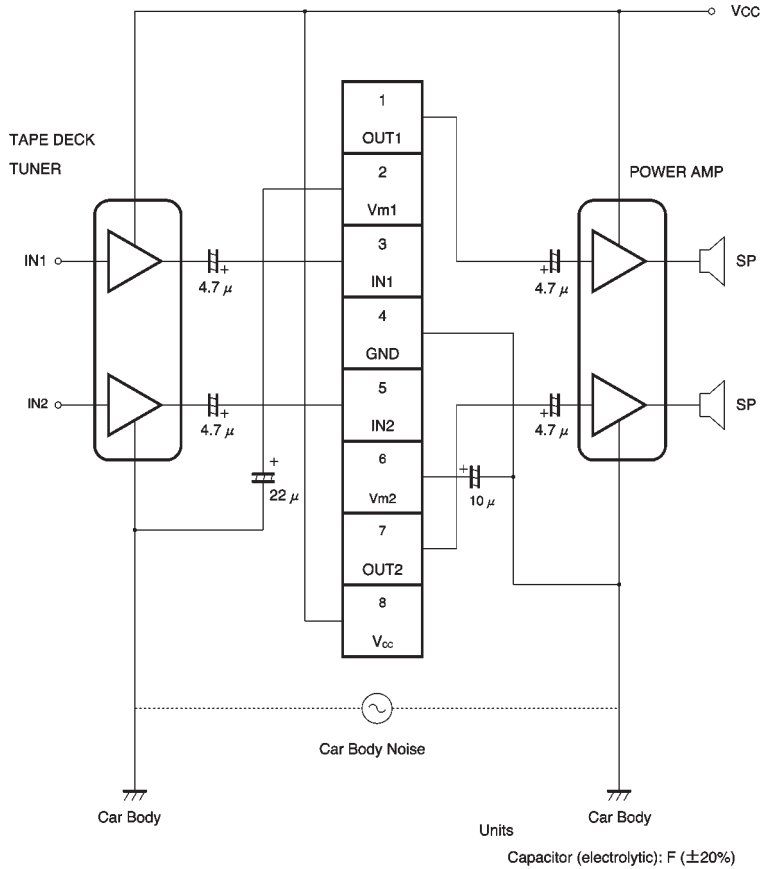

Fig. 6

● Electrical characteristics curves

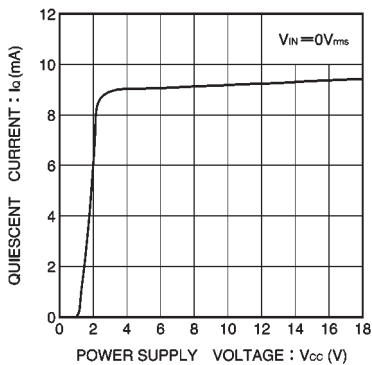

Fig. 7 Quiescent current vs. power supply voltage

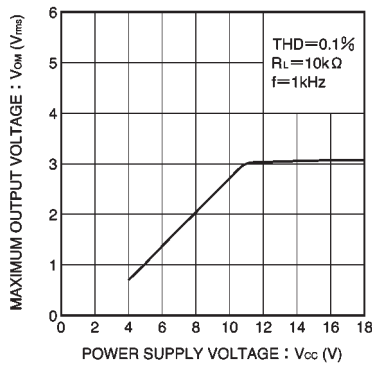

Fig. 8 Maximum output voltage vs. power supply voltage

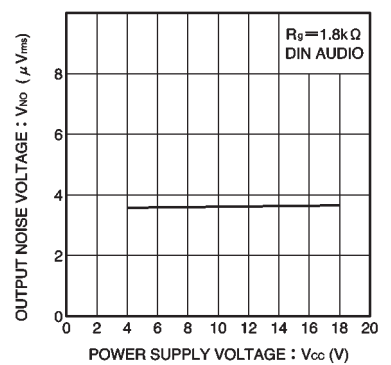

Fig. 9 Output noise voltage vs. power supply voltage

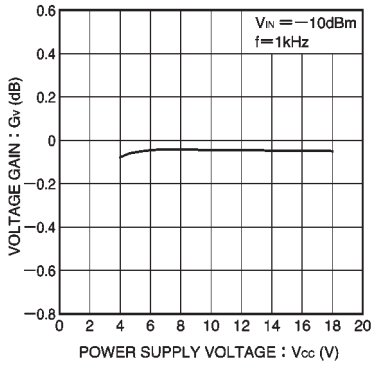

Fig. 10 Voltage gain vs. power supply voltage

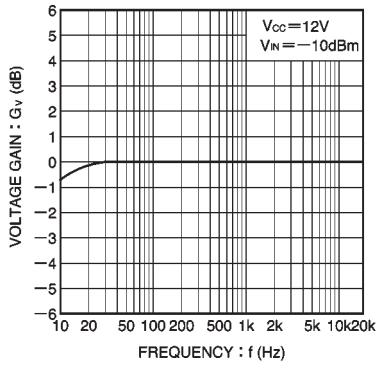

Fig. 11 Voltage gain vs. frequency

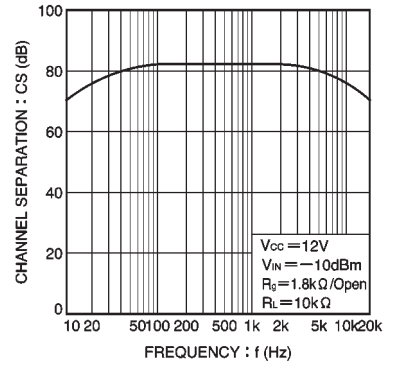

Fig. 12 Channel separation vs. frequency

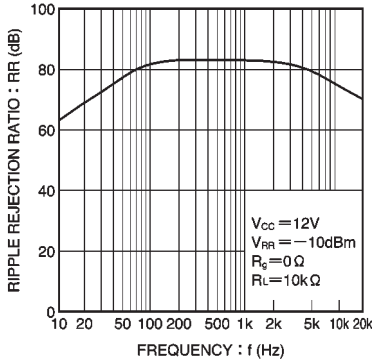

Fig. 13 Ripple rejection ratio vs. frequency

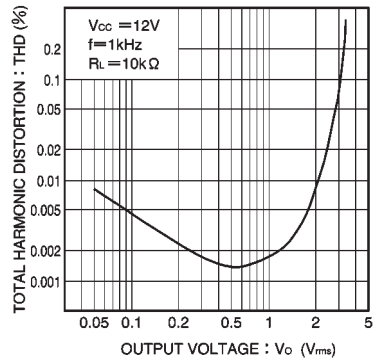

Fig. 14 Total harmonic distortion vs. output voltage

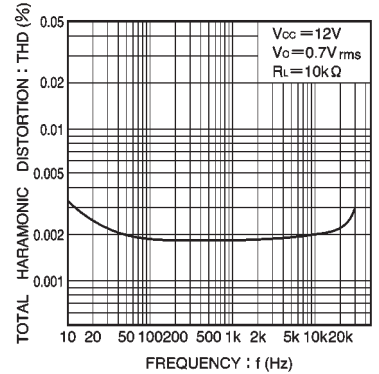

Fig. 15 Total harmonic distortion vs. frequency

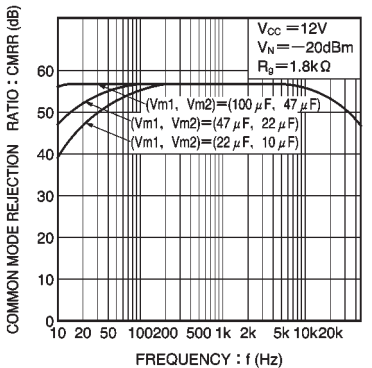

Fig. 16 Common-mode rejection ratio vs. frequency

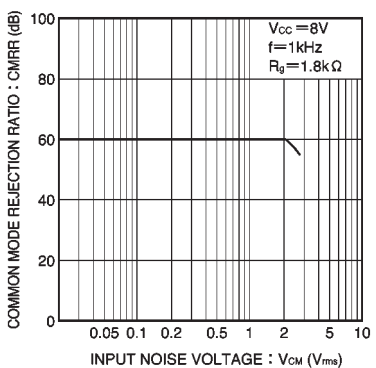
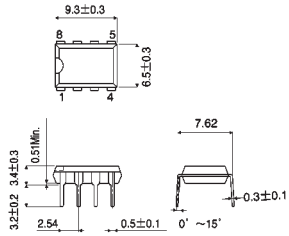

Fig. 17 Common-mode rejection ratio vs. input voltage



● External dimensions (Units: mm)

BA3121



DIP8

BA3121F

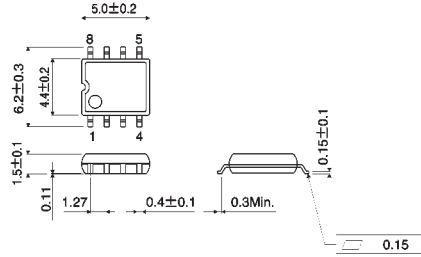

SOP8

BA3121N

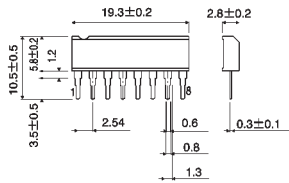

SIP8

# MEMO

# MEMO