

AN5757S

CRT horizontal deflection voltage control IC

■ Overview

The AN5757S is an IC for PWM-system CRT horizontal deflection voltage control. It can be used for horizontal frequency from 20 kHz to 140 kHz and applicable from a popular type monitor to high precision monitor. Its SO-16-pin package enables the users to design the sets simple and efficient.

■ Features

- PWM output
- Built-in thermal protection circuit (cut off both upper and lower push-pull output transistor)
- Soft start function
- Built-in error amp.

■ Applications

- CRT monitors

■ Block Diagram

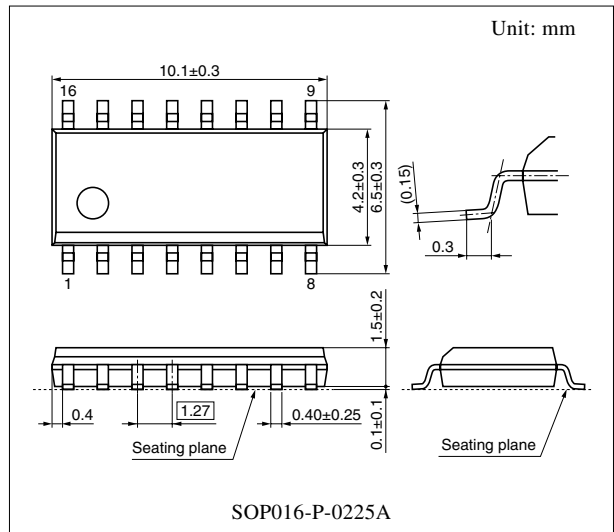
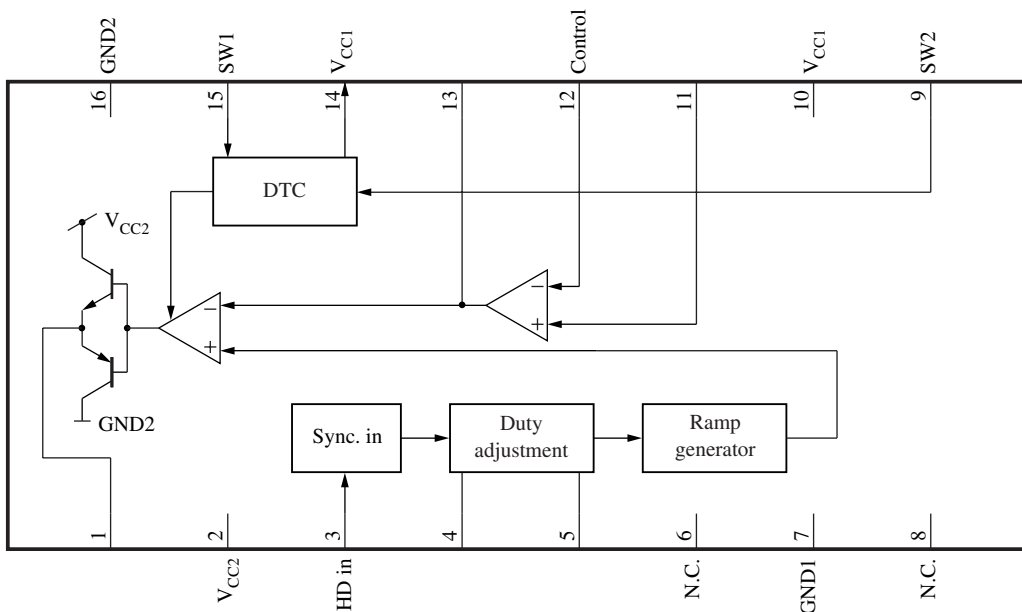

Note) The package of this product will be changed to lead-free type (SOP16-P-0225E). See the new package dimensions section later of this datasheet.

■ Pin Descriptions

Pin No.	Description	Pin No.	Description
1	PWM output	9	On/off SW input2 (SW2)
2	Power supply for output (V_{CC2})	10	Power supply (V_{CC1})
3	Horizontal synchronous input (HD in)	11	IN+
4	Duty adjustment (capacitor)	12	IN-
5	Duty adjustment (resistor)	13	NF
6	N.C.	14	Capacitor for DTC
7	GND1	15	On/off SW input1 (SW1)
8	N.C.	16	GND2

■ Absolute Maximum Ratings

Parameter	Symbol	Rating	Unit
Supply voltage	V_{CC1}	13.2	V
	V_{CC2}	13.2	
Supply current	I_{CC1}	6.3	mA
	I_{CC2}	15.0	
Output current	I_1	± 150	mA
Power dissipation *2	P_D	198	mW
Operating ambient temperature *1	T_{opr}	-20 to +70	$^{\circ}\text{C}$
Storage temperature *1	T_{stg}	-55 to +125	$^{\circ}\text{C}$

Note) *1: Except for the power dissipation, operating ambient temperature, and storage temperature, all ratings are for $T_a = 25^{\circ}\text{C}$.

*2: The power dissipation shown is for the IC package in free air at $T_a = 70^{\circ}\text{C}$.

■ Recommended Operating Range

Parameter	Symbol	Range	Unit
Supply voltage	V_{CC1}, V_{CC2}	11.0 to 13.0	V
HD input	V_3	0 to V_{10}	V
SW1 input	V_{115}	0 to V_{10}	V
SW2 input	V_{19}	0 to V_{10}	V
Max. duty adjustment voltage	V_5	0 to 6	V
Error amp. positive input	V_{11}	0 to 6	V
Error amp. negative input	V_{12}	0 to 6	V
Max. output current of PWM output	$I_{1(max)}$	-150 to +150	mA

Note) '+' denotes current flowing into the IC, and '-' denotes current flowing out of the IC.

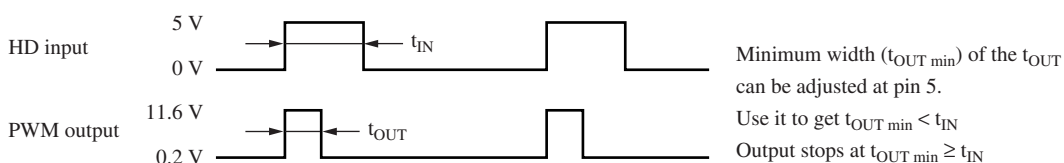

■ Electrical Characteristics at $T_a = 25^\circ\text{C}$

Parameter	Symbol	Conditions	Min	Typ	Max	Unit
Power supply current	I_{CC1}	$V_{CC} = 12\text{ V}$, $V_{9,15} = 5\text{ V}$, $V_3 = 5\text{ V}$, $V_{11} = 0\text{ V}$	2.0	4.0	6.0	mA
Power supply current for output	I_{CC2}	$V_{CC} = 12\text{ V}$, $V_{9,15} = 5\text{ V}$, $V_3 = 5\text{ V}$, $V_{11} = 0\text{ V}$	6.0	10.0	14.0	mA
Duty						
Pin voltage of duty adjustment resistor pin	V_{5-7}	$V_{CC} = 12\text{ V}$, $V_3 = 0\text{ V}$	2.0	3.0	4.0	V
Pin current (for discharge) of duty adjustment capacitor pin	I_{4D}	$V_{CC} = 12\text{ V}$, $V_3 = 0\text{ V}$, $V_4 = 1\text{ V}$	3.0	—	—	mA
Pin current (for charge) of duty adjustment capacitor pin	I_{4C}	$V_{CC} = 12\text{ V}$, $V_3 = 5\text{ V}$, $V_4 = 1\text{ V}$	-60	-45	-30	μA
High-level of duty adjustment capacitor pin	V_{4-7H}	$V_{CC} = 12\text{ V}$, $V_3 = 5\text{ V}$	3.2	3.7	4.2	V
Low-level of duty adjustment capacitor pin	V_{4-7L}	$V_{CC} = 12\text{ V}$, $V_3 = 0\text{ V}$	0	—	0.15	V
DTC						
SW2 pin current H	I_{9H}	$V_{CC} = 12\text{ V}$, $V_3 = 5\text{ V}$, $V_9 = 12\text{ V}$	200	300	400	μA
SW2 pin current M	I_{9M}	$V_{CC} = 12\text{ V}$, $V_3 = 5\text{ V}$, $V_9 = 5\text{ V}$	45	70	95	μA
SW2 pin current L	I_{9L}	$V_{CC} = 12\text{ V}$, $V_3 = 5\text{ V}$, $V_9 = 0\text{ V}$	-5	—	0	μA
SW1 pin current H	I_{15H}	$V_{CC} = 12\text{ V}$, $V_3 = 5\text{ V}$, $V_{15} = 12\text{ V}$	200	300	400	μA
SW1 pin current M	I_{15M}	$V_{CC} = 12\text{ V}$, $V_3 = 5\text{ V}$, $V_{15} = 5\text{ V}$	45	70	95	μA
SW1 pin current L	I_{15L}	$V_{CC} = 12\text{ V}$, $V_3 = 5\text{ V}$, $V_{15} = 0\text{ V}$	-5	—	0	μA
Pin current (discharge) of DTC capacitor pin	I_{14D}	$V_{CC} = 12\text{ V}$, $V_{14} = 5\text{ V}$, $V_{9,15} = 12\text{ V}$	60	90	120	μA
Pin current (charge) of DTC capacitor pin	I_{14C}	$V_{CC} = 12\text{ V}$, $V_{14} = 10\text{ V}$, $V_{9,15} = 0\text{ V}$	-15	-8	-1	mA
High-level of DTC capacitor pin	V_{14-7H}	$V_{CC} = 12\text{ V}$, $V_{9,15} = 0\text{ V}$	11.5	—	—	V
Low-level of DTC capacitor pin	V_{14-7L}	$V_{CC} = 12\text{ V}$, $V_{9,15} = 12\text{ V}$	0	—	0.15	V

■ Electrical Characteristics at $T_a = 25^\circ\text{C}$ (continued)

Parameter	Symbol	Conditions	Min	Typ	Max	Unit
PWM output						
High-level of PWM output pin (no load)	V_{1-16H1}	$V_{CC} = 12\text{ V}$, $V_3 = 0\text{ V}$, pin 1: Open	11.0	—	—	V
Low-level of PWM output pin (no load)	V_{1-16L1}	$V_{CC} = 12\text{ V}$, $V_3 = 5\text{ V}$, pin 1: Open	0	—	1.0	V
High-level of PWM output pin (with load)	V_{1-16H2}	$V_{CC} = 12\text{ V}$, $V_3 = 0\text{ V}$, $I_1 = -150\text{ mA}$	8.0	10.0	11.5	V
Low-level of PWM output pin (with load)	V_{1-16L2}	$V_{CC} = 12\text{ V}$, $V_3 = 5\text{ V}$, $I_1 = +150\text{ mA}$	0.5	1.5	2.5	V

• Design reference data

Note) The characteristics listed below are theoretical values based on the IC design and are not guaranteed.

Parameter	Symbol	Conditions	Min	Typ	Max	Unit
HD input frequency	f_3	$V_{CC} = 12\text{ V}$, $V_{9,15} = 12\text{ V}$, $V_{11} = 0\text{ V}$	20	—	140	kHz
HD input threshold value	V_{3TH}	$V_{CC} = 12\text{ V}$, $V_{9,15} = 12\text{ V}$, $V_{11} = 0\text{ V}$	0.6	1	1.4	V
Open gain of error amp.	A	$V_{CC} = 12\text{ V}$	—	80	—	dB
Current capability of PWM output pin	I_1	$V_{CC} = 12\text{ V}$	-150	—	+150	mA
Operation start voltage	V_{10-7N}	$V_{11} = 0\text{ V}$, $V_3 = 5\text{ V}$	8.1	8.5	8.9	V
Operation stop voltage	V_{10-7F}	$V_{11} = 0\text{ V}$, $V_3 = 5\text{ V}$	6.1	6.5	6.9	V
SW1 threshold value	V_{S15}	$V_{CC} = 12\text{ V}$, $V_{11} = 0\text{ V}$, $V_3 = 5\text{ V}$	1.1	1.5	1.9	V
SW2 threshold value	V_{S9}	$V_{CC} = 12\text{ V}$, $V_{11} = 0\text{ V}$, $V_3 = 5\text{ V}$	1.1	1.5	1.9	V

■ Terminal Equivalent Circuits

Pin No.	Equivalent circuit	Description	Waveform
1		PWM output: Pin for output	
2		Power supply for output: Power supply for PWM output Apply DC 12 V.	DC 12 V

■ Terminal Equivalent Circuits (continued)

Pin No.	Equivalent circuit	Description	Waveform
3		<p>Horizontal synchronizing signal input: Input pin of horizontal synchronizing signal Detection level is 1 V.</p>	
4		<p>For duty adjustment (capacitor): Duty can be adjusted by attaching a capacitor between the pin and GND. If capacitance is raised, duty becomes small.</p>	
5		<p>Duty adjustment (resistor): Duty can be adjusted by attaching a resistor between the pin and GND. If resistance is lowered, duty becomes large.</p>	<p>DC 0.5 V to 5.0 V variable</p>
6	—	N.C.: Pin for N.C.	—
7		GND1: Pin for GND	0 V
8	—	N.C.: Pin for N.C.	—
9		<p>Switch input2 for on/off: On/off switch pin for PWM output On at 2 V or more and off at 0 V. (Threshold level: 1.5 V)</p>	<p>Pin 9 Pin 1 0 V → High (11 V) 2 V or more → Low (1 V)</p>
10		<p>Power supply: Power supply pin Apply DC 12 V.</p>	DC 12 V

■ Terminal Equivalent Circuits (continued)

Pin No.	Equivalent circuit	Description	Waveform
11		IN+: Input pin for + side input pin for error amp.	—
12		IN-: Input pin for - side input pin for error amp.	
13		NF: Output pin for error amp.	—
14		Capacitor for DTC: Capacitor pin to determine a soft start time If capacitance is raised, time becomes long.	—
15		Switch input1 for on/off: On/off switch pin for PWM output. On at 2 V or more and off at 0 V. (Threshold level: 1.5 V)	Pin 15 Pin 1 0 V → High (11 V) 2 V or more → Low (1 V)
16		GND2 Pin for GND.	0 V

■ Usage Notes

- Allowable mode of short-circuit between pins

Short circuit allowable pins are marked with ● symbol.

It has been confirmed that a typical IC sample does not break down even if pins are short-circuited for one second.

It has been confirmed that a typical IC sample does not emitting smoke and fire even if pins are short-circuited for ten seconds. This is not inspected for all ICs.

The mark × shows that a breakdown may be caused if the pins are short-circuited. Full care must be taken on using the IC.

1																
2	●															
3	●	●														
4	●	●	●													
5	●	●	●	●												
6	●	●	●	●	●											
7	●	×	●	●	●	●										
8	●	●	●	●	●	●	●									
9	●	●	●	●	●	●	●	●								
10	●	●	●	●	●	●	×	●	●							
11	●	●	●	●	●	●	●	●	●	●						
12	●	●	●	●	●	●	●	●	●	●	●					
13	●	●	●	●	●	●	●	●	●	●	●	●				
14	●	●	●	●	●	●	●	●	●	●	●	●	●			
15	●	●	●	●	●	●	●	●	●	●	●	●	●	●		
16	●	×	●	●	●	●	●	●	●	×	●	●	●	●	●	
Pin No.	1	2	3	4	5	6	7	8	9	10	11	12	13	14	15	16

■ Application Circuit Example

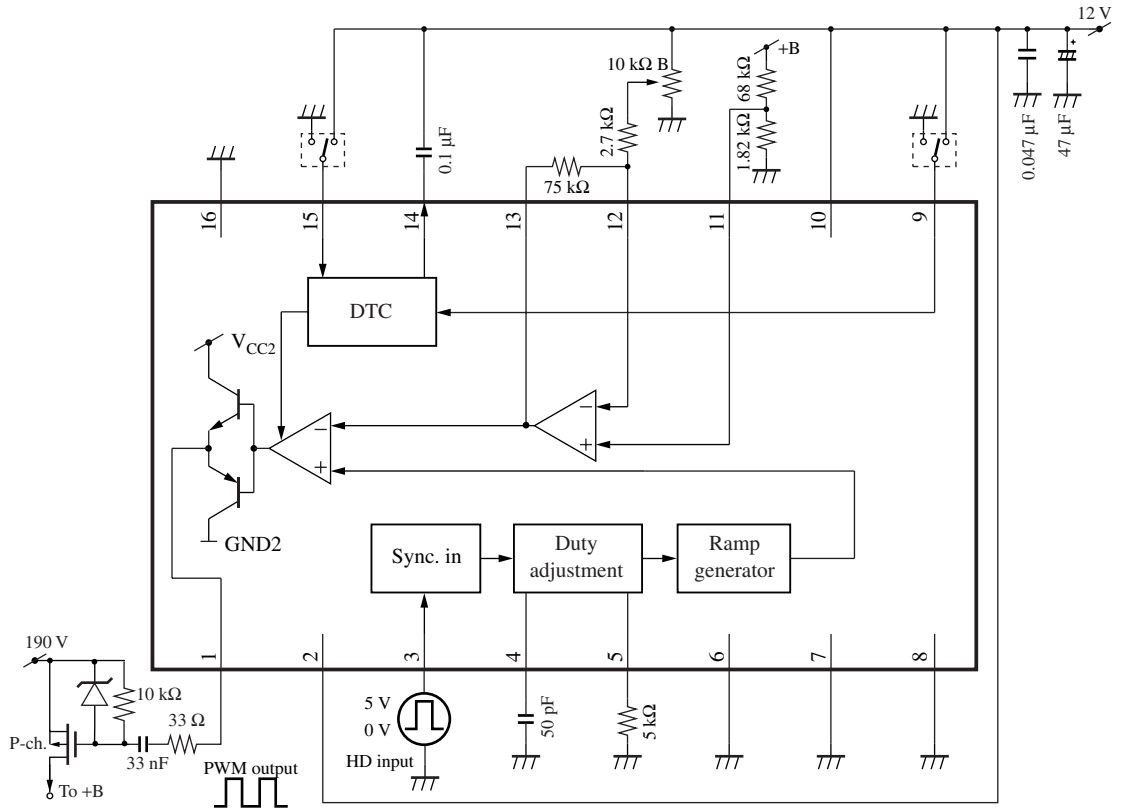

Note) When both of the pin 4 and the pin 5 are open, minimum pulse width of PWM output is 2.0 μs.

■ New Package Dimensions (Unit: mm)

- SOP016-P-0225E (Lead-free package)

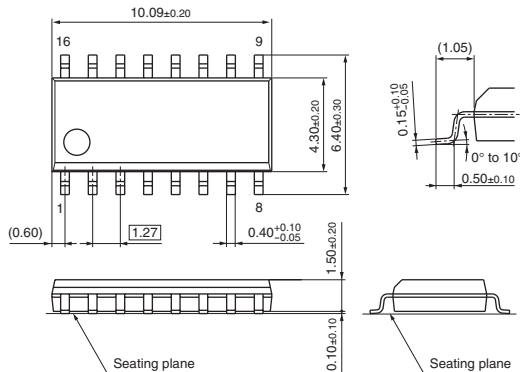

Request for your special attention and precautions in using the technical information and semiconductors described in this material

- (1) An export permit needs to be obtained from the competent authorities of the Japanese Government if any of the products or technologies described in this material and controlled under the "Foreign Exchange and Foreign Trade Law" is to be exported or taken out of Japan.
- (2) The technical information described in this material is limited to showing representative characteristics and applied circuit examples of the products. It does not constitute the warranting of industrial property, the granting of relative rights, or the granting of any license.
- (3) The products described in this material are intended to be used for standard applications or general electronic equipment (such as office equipment, communications equipment, measuring instruments and household appliances).
Consult our sales staff in advance for information on the following applications:
 - Special applications (such as for airplanes, aerospace, automobiles, traffic control equipment, combustion equipment, life support systems and safety devices) in which exceptional quality and reliability are required, or if the failure or malfunction of the products may directly jeopardize life or harm the human body.
 - Any applications other than the standard applications intended.
- (4) The products and product specifications described in this material are subject to change without notice for reasons of modification and/or improvement. At the final stage of your design, purchasing, or use of the products, therefore, ask for the most up-to-date Product Standards in advance to make sure that the latest specifications satisfy your requirements.
- (5) When designing your equipment, comply with the guaranteed values, in particular those of maximum rating, the range of operating power supply voltage and heat radiation characteristics. Otherwise, we will not be liable for any defect which may arise later in your equipment.
Even when the products are used within the guaranteed values, redundant design is recommended, so that such equipment may not violate relevant laws or regulations because of the function of our products.
- (6) When using products for which dry packing is required, observe the conditions (including shelf life and after-unpacking standby time) agreed upon when specification sheets are individually exchanged.
- (7) No part of this material may be reprinted or reproduced by any means without written permission from our company.

Please read the following notes before using the datasheets

- A. These materials are intended as a reference to assist customers with the selection of Panasonic semiconductor products best suited to their applications.
Due to modification or other reasons, any information contained in this material, such as available product types, technical data, and so on, is subject to change without notice.
Customers are advised to contact our semiconductor sales office and obtain the latest information before starting precise technical research and/or purchasing activities.
- B. Panasonic is endeavoring to continually improve the quality and reliability of these materials but there is always the possibility that further rectifications will be required in the future. Therefore, Panasonic will not assume any liability for any damages arising from any errors etc. that may appear in this material.
- C. These materials are solely intended for a customer's individual use.
Therefore, without the prior written approval of Panasonic, any other use such as reproducing, selling, or distributing this material to a third party, via the Internet or in any other way, is prohibited.