

### FEATURES

- True RMS-to-DC Conversion
- 200 mV Full Scale
- Laser-Trimmed to High Accuracy
  - 0.5% max Error (AD636K)
  - 1.0% max Error (AD636J)
- Wide Response Capability:
  - Computes RMS of AC and DC Signals
  - 1 MHz  $-3$  dB Bandwidth:  $V_{RMS} > 100$  mV
  - Signal Crest Factor of 6 for 0.5% Error
- dB Output with 50 dB Range
- Low Power: 800  $\mu$ A Quiescent Current
- Single or Dual Supply Operation
- Monolithic Integrated Circuit
- Low Cost
- Available in Chip Form

### PRODUCT DESCRIPTION

The AD636 is a low power monolithic IC which performs true rms-to-dc conversion on low level signals. It offers performance which is comparable or superior to that of hybrid and modular converters costing much more. The AD636 is specified for a signal range of 0 mV to 200 mV rms. Crest factors up to 6 can be accommodated with less than 0.5% additional error, allowing accurate measurement of complex input waveforms.

The low power supply current requirement of the AD636, typically 800  $\mu$ A, allows it to be used in battery-powered portable instruments. A wide range of power supplies can be used, from  $\pm 2.5$  V to  $\pm 16.5$  V or a single +5 V to +24 V supply. The input and output terminals are fully protected; the input signal can exceed the power supply with no damage to the device (allowing the presence of input signals in the absence of supply voltage) and the output buffer amplifier is short-circuit protected.

The AD636 includes an auxiliary dB output. This signal is derived from an internal circuit point which represents the logarithm of the rms output. The 0 dB reference level is set by an externally supplied current and can be selected by the user to correspond to any input level from 0 dBm (774.6 mV) to  $-20$  dBm (77.46 mV). Frequency response ranges from 1.2 MHz at a 0 dBm level to over 10 kHz at  $-50$  dBm.

The AD636 is designed for ease of use. The device is factory-trimmed at the wafer level for input and output offset, positive and negative waveform symmetry (dc reversal error), and full-scale accuracy at 200 mV rms. Thus no external trims are required to achieve full-rated accuracy.

AD636 is available in two accuracy grades; the AD636J total error of  $\pm 0.5$  mV  $\pm 0.06\%$  of reading, and the AD636K

### REV. A

Information furnished by Analog Devices is believed to be accurate and reliable. However, no responsibility is assumed by Analog Devices for its use, nor for any infringements of patents or other rights of third parties which may result from its use. No license is granted by implication or otherwise under any patent or patent rights of Analog Devices.

### PIN CONNECTIONS & FUNCTIONAL BLOCK DIAGRAM

“D” Package  
(TO-116)

“H” Package  
(TO-100)

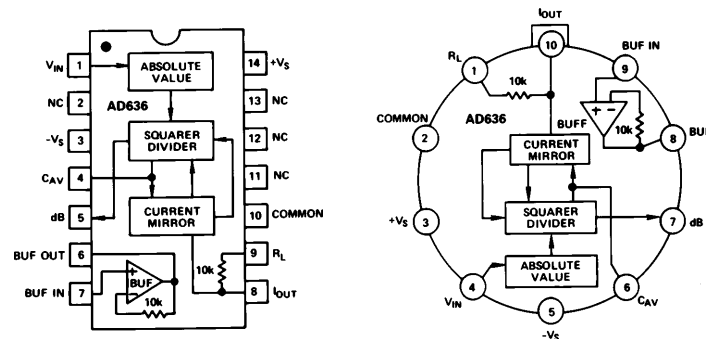

is accurate within  $\pm 0.2$  mV to  $\pm 0.3\%$  of reading. Both versions are specified for the  $0^\circ\text{C}$  to  $+70^\circ\text{C}$  temperature range, and are offered in either a hermetically sealed 14-pin DIP or a 10-pin TO-100 metal can. Chips are also available.

### PRODUCT HIGHLIGHTS

1. The AD636 computes the true root-mean-square of a complex ac (or ac plus dc) input signal and gives an equivalent dc output level. The true rms value of a waveform is a more useful quantity than the average rectified value since it is a measure of the power in the signal. The rms value of an ac-coupled signal is also its standard deviation.
2. The 200 millivolt full-scale range of the AD636 is compatible with many popular display-oriented analog-to-digital converters. The low power supply current requirement permits use in battery powered hand-held instruments.
3. The only external component required to perform measurements to the fully specified accuracy is the averaging capacitor. The value of this capacitor can be selected for the desired trade-off of low frequency accuracy, ripple, and settling time.
4. The on-chip buffer amplifier can be used to buffer either the input or the output. Used as an input buffer, it provides accurate performance from standard 10 M $\Omega$  input attenuators. As an output buffer, it can supply up to 5 milliamps of output current.
5. The AD636 will operate over a wide range of power supply voltages, including single +5 V to +24 V or split  $\pm 2.5$  V to  $\pm 16.5$  V sources. A standard 9 V battery will provide several hundred hours of continuous operation.

# AD636—SPECIFICATIONS (@ +25°C, and +V<sub>S</sub> = +3 V, -V<sub>S</sub> = -5 V, unless otherwise noted)

Model	AD636J			AD636K			Units
	Min	Typ	Max	Min	Typ	Max	
TRANSFER FUNCTION	$V_{OUT} = \sqrt{\text{avg.}(V_{IN})^2}$			$V_{OUT} = \sqrt{\text{avg.}(V_{IN})^2}$			
CONVERSION ACCURACY							
Total Error, Internal Trim <sup>1, 2</sup> vs. Temperature, 0°C to +70°C			$\pm 0.5 \pm 1.0$ $\pm 0.1 \pm 0.01$			$\pm 0.2 \pm 0.5$ $\pm 0.1 \pm 0.005$	mV $\pm$ % of Reading mV $\pm$ % of Reading/°C
vs. Supply Voltage			$\pm 0.1 \pm 0.01$			$\pm 0.1 \pm 0.01$	mV $\pm$ % of Reading/V
dc Reversal Error at 200 mV			$\pm 0.2$			$\pm 0.1$	% of Reading
Total Error, External Trim <sup>1</sup>			$\pm 0.3 \pm 0.3$			$\pm 0.1 \pm 0.2$	mV $\pm$ % of Reading
ERROR VS. CREST FACTOR <sup>3</sup>							
Crest Factor 1 to 2	Specified Accuracy			Specified Accuracy			% of Reading
Crest Factor = 3	-0.2			-0.2			% of Reading
Crest Factor = 6	-0.5			-0.5			% of Reading
AVERAGING TIME CONSTANT	25			25			ms/ $\mu$ F CAV
INPUT CHARACTERISTICS							
Signal Range, All Supplies Continuous rms Level	0 to 200			0 to 200			mV rms
Peak Transient Inputs							
+3 V, -5 V Supply	$\pm 2.8$			$\pm 2.8$			V pk
$\pm 2.5$ V Supply	$\pm 2.0$			$\pm 2.0$			V pk
$\pm 5$ V Supply	$\pm 5.0$			$\pm 5.0$			V pk
Maximum Continuous Nondestructive Input Level (All Supply Voltages)	$\pm 12$			$\pm 12$			V pk
Input Resistance	5.33	6.67	8	5.33	6.67	8	k $\Omega$
Input Offset Voltage	$\pm 0.5$			$\pm 0.2$			mV
FREQUENCY RESPONSE <sup>2, 4</sup>							
Bandwidth for 1% Additional Error (0.09 dB)							
V <sub>IN</sub> = 10 mV	14			14			kHz
V <sub>IN</sub> = 100 mV	90			90			kHz
V <sub>IN</sub> = 200 mV	130			130			kHz
$\pm 3$ dB Bandwidth							
V <sub>IN</sub> = 10 mV	100			100			kHz
V <sub>IN</sub> = 100 mV	900			900			MHz
V <sub>IN</sub> = 200 mV	1.5			1.5			MHz
OUTPUT CHARACTERISTICS <sup>2</sup>							
Offset Voltage, V <sub>IN</sub> = COM vs. Temperature	$\pm 10$			$\pm 10$			mV $\mu$ V/°C
vs. Supply	$\pm 0.1$			$\pm 0.1$			mV/V
Voltage Swing							
+3 V, -5 V Supply	0.3	0 to +1.0		0.3	0 to +1.0		V
$\pm 5$ V to $\pm 16.5$ V Supply	0.3	0 to +1.0		0.3	0 to +1.0		V
Output Impedance	8	10	12	8	10	12	k $\Omega$
dB OUTPUT							
Error, V <sub>IN</sub> = 7 mV to 300 mV rms	$\pm 0.3$			$\pm 0.1$			dB
Scale Factor	-3.0			-3.0			mV/dB
Scale Factor Temperature Coefficient	+0.33 -0.033			+0.33 -0.033			% of Reading/°C dB/°C
I <sub>REF</sub> for 0 dB = 0.1 V rms	2	4	8	2	4	8	$\mu$ A
I <sub>REF</sub> Range	1		50	1		50	$\mu$ A
I <sub>OUT</sub> TERMINAL							
I <sub>OUT</sub> Scale Factor	100			100			$\mu$ A/V rms
I <sub>OUT</sub> Scale Factor Tolerance	-20	$\pm 10$	+20	-20	$\pm 10$	+20	%
Output Resistance	8	10	12	8	10	12	k $\Omega$
Voltage Compliance	$-V_S$ to (+V <sub>S</sub> -2 V)			$-V_S$ to (+V <sub>S</sub> -2 V)			V
BUFFER AMPLIFIER							
Input and Output Voltage Range	$-V_S$ to (+V <sub>S</sub> -2 V)			$-V_S$ to (+V <sub>S</sub> -2 V)			V
Input Offset Voltage, R <sub>S</sub> = 10k	$\pm 0.8$			$\pm 0.5$			mV
Input Bias Current	100 300			100 300			nA
Input Resistance	$10^8$			$10^8$			$\Omega$
Output Current	(+5 mA, -130 $\mu$ A)			(+5 mA, -130 $\mu$ A)			
Short Circuit Current	20			20			mA
Small Signal Bandwidth	1			1			MHz
Slew Rate <sup>5</sup>	5			5			V/ $\mu$ s
POWER SUPPLY							
Voltage, Rated Performance	+3, -5			+3, -5			V
Dual Supply	+2, -2.5		$\pm 16.5$	+2, -2.5		$\pm 16.5$	V
Single Supply	+5		+24	+5		+24	V
Quiescent Current <sup>6</sup>	0.80			0.80			mA

Model	AD636J			AD636K			Units
	Min	Typ	Max	Min	Typ	Max	
TEMPERATURE RANGE							
Rated Performance	0		+70	0		+70	°C
Storage	-55		+150	-55		+150	°C
TRANSISTOR COUNT	62			62			

**NOTES**

<sup>1</sup>Accuracy specified for 0 mV to 200 mV rms, dc or 1 kHz sine wave input. Accuracy is degraded at higher rms signal levels.

<sup>2</sup>Measured at Pin 8 of DIP ( $I_{OUT}$ ), with Pin 9 tied to common.

<sup>3</sup>Error vs. crest factor is specified as additional error for a 200 mV rms rectangular pulse trim, pulse width = 200  $\mu$ s.

<sup>4</sup>Input voltages are expressed in volts rms.

<sup>5</sup>With 10 k $\Omega$  pull down resistor from Pin 6 (BUF OUT) to  $-V_S$ .

<sup>6</sup>With BUF input tied to Common.

Specifications subject to change without notice.

All min and max specifications are guaranteed. Specifications shown in **boldface** are tested on all production units at final electrical test and are used to calculate outgoing quality levels.

**ABSOLUTE MAXIMUM RATINGS<sup>1</sup>**

**Supply Voltage**

Dual Supply	$\pm 16.5$ V
Single Supply	+24 V
Internal Power Dissipation <sup>2</sup>	500 mW
Maximum Input Voltage	$\pm 12$ V Peak
Storage Temperature Range N, R	-55°C to +150°C
Operating Temperature Range	
AD636J/K	0°C to +70°C
Lead Temperature Range (Soldering 60 sec)	+300°C
ESD Rating	1000 V

**NOTES**

<sup>1</sup>Stresses above those listed under "Absolute Maximum Ratings" may cause permanent damage to the device. This is a stress rating only and functional operation of the device at these or any other conditions above those indicated in the operational section of this specification is not implied. Exposure to absolute maximum rating conditions for extended periods may affect device reliability.

<sup>2</sup>10-Pin Header:  $\theta_{JA} = 150^\circ\text{C/Watt}$ .

14-Pin Side Brazed Ceramic DIP:  $\theta_{JA} = 95^\circ\text{C/Watt}$ .

**METALIZATION PHOTOGRAPH**

Contact factory for latest dimensions.

Dimensions shown in inches and (mm).

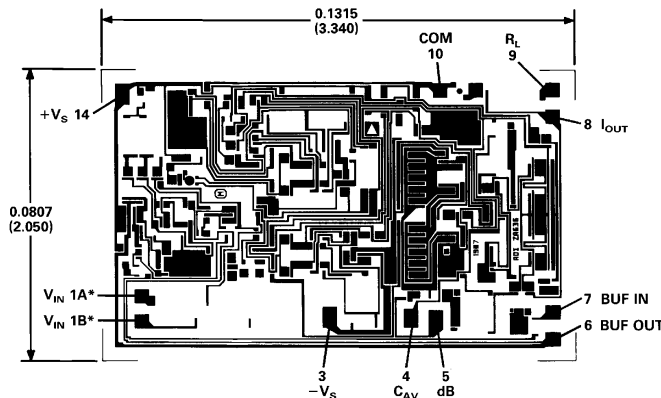

PAD NUMBERS CORRESPOND TO PIN NUMBERS FOR THE TO-116 14-PIN CERAMIC DIP PACKAGE.

NOTE  
\*BOTH PADS SHOWN MUST BE CONNECTED TO  $V_{IN}$ .

**ORDERING GUIDE**

Model	Temperature Range	Package Description	Package Option
AD636JD	0°C to +70°C	Side Brazed Ceramic DIP	D-14
AD636KD	0°C to +70°C	Side Brazed Ceramic DIP	D-14
AD636JH	0°C to +70°C	Header	H-10A
AD636KH	0°C to +70°C	Header	H-10A
AD636J Chip	0°C to +70°C	Chip	
AD636K Chip	0°C to +70°C	Chip	

**STANDARD CONNECTION**

The AD636 is simple to connect for the majority of high accuracy rms measurements, requiring only an external capacitor to set the averaging time constant. The standard connection is shown in Figure 1. In this configuration, the AD636 will measure the rms of the ac and dc level present at the input, but will show an error for low frequency inputs as a function of the filter capacitor,  $C_{AV}$ , as shown in Figure 5. Thus, if a 4  $\mu$ F capacitor is used, the additional average error at 10 Hz will be 0.1%, at 3 Hz it will be 1%. The accuracy at higher frequencies will be according to specification. If it is desired to reject the dc input, a capacitor is added in series with the input, as shown in Figure 3; the capacitor must be nonpolar. If the AD636 is driven with power supplies with a considerable amount of high frequency ripple, it is advisable to bypass both supplies to ground with 0.1  $\mu$ F ceramic discs as near the device as possible.  $C_F$  is an optional output ripple filter, as discussed elsewhere in this data sheet.

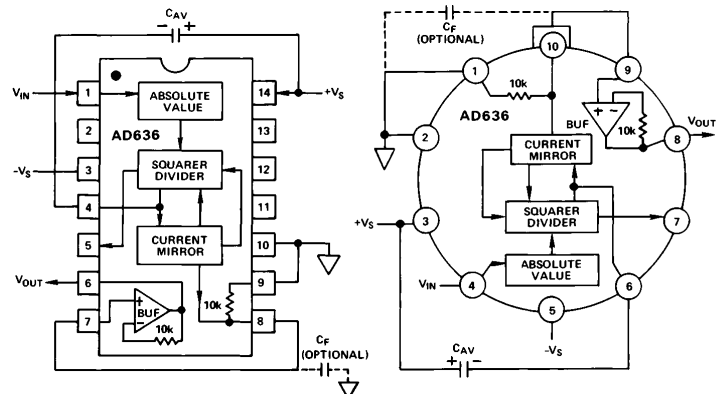

Figure 1. Standard RMS Connection

# Applying the AD636

The input and output signal ranges are a function of the supply voltages as detailed in the specifications. The AD636 can also be used in an unbuffered voltage output mode by disconnecting the input to the buffer. The output then appears unbuffered across the 10k resistor. The buffer amplifier can then be used for other purposes. Further, the AD636 can be used in a current output mode by disconnecting the 10k resistor from the ground. The output current is available at Pin 8 (Pin 10 on the "H" package) with a nominal scale of 100  $\mu$ A per volt rms input, positive out.

## OPTIONAL TRIMS FOR HIGH ACCURACY

If it is desired to improve the accuracy of the AD636, the external trims shown in Figure 2 can be added. R4 is used to trim the offset. The scale factor is trimmed by using R1 as shown. The insertion of R2 allows R1 to either increase or decrease the scale factor by  $\pm 1.5\%$ .

The trimming procedure is as follows:

1. Ground the input signal,  $V_{IN}$ , and adjust R4 to give zero volts output from Pin 6. Alternatively, R4 can be adjusted to give the correct output with the lowest expected value of  $V_{IN}$ .
2. Connect the desired full-scale input level to  $V_{IN}$ , either dc or a calibrated ac signal (1 kHz is the optimum frequency); then trim R1 to give the correct output from Pin 6, i.e., 200 mV dc input should give 200 mV dc output. Of course, a  $\pm 200$  mV peak-to-peak sine wave should give a 141.4 mV dc output. The remaining errors, as given in the specifications, are due to the nonlinearity.

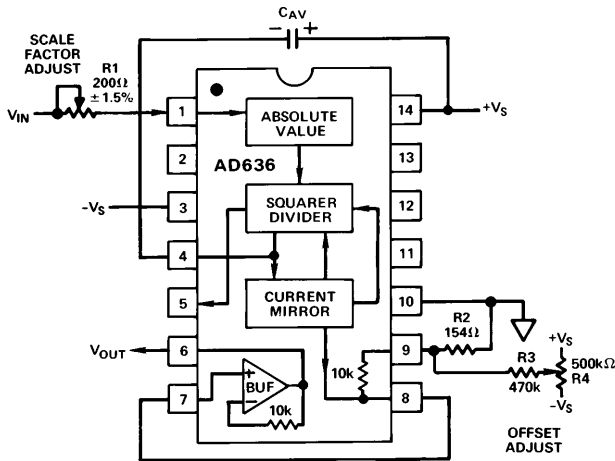

Figure 2. Optional External Gain and Output Offset Trims

## SINGLE SUPPLY CONNECTION

The applications in Figures 1 and 2 assume the use of dual power supplies. The AD636 can also be used with only a single positive supply down to +5 volts, as shown in Figure 3. Figure 3 is optimized for use with a 9 volt battery. The major limitation of this connection is that only ac signals can be measured since the input stage must be biased off ground for proper operation. This biasing is done at Pin 10; thus it is critical that no extraneous signals be coupled into this point. Biasing can be accomplished by using a resistive divider between + $V_S$  and ground. The values of the resistors can be increased in the interest of lowered power consumption, since only 1 microamp of current flows into Pin 10 (Pin 2 on the "H" package). Alternately, the

COM pin of some CMOS ADCs provides a suitable artificial ground for the AD636. AC input coupling requires only capacitor C2 as shown; a dc return is not necessary as it is provided internally. C2 is selected for the proper low frequency break point with the input resistance of 6.7 k $\Omega$ ; for a cut-off at 10 Hz, C2 should be 3.3  $\mu$ F. The signal ranges in this connection are slightly more restricted than in the dual supply connection. The load resistor,  $R_L$ , is necessary to provide current sinking capability.

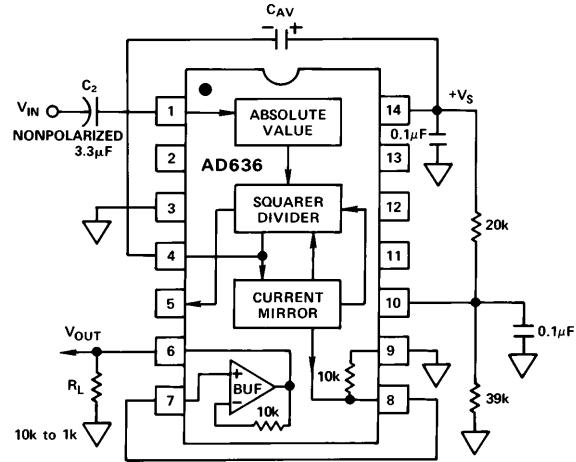

Figure 3. Single Supply Connection

## CHOOSING THE AVERAGING TIME CONSTANT

The AD636 will compute the rms of both ac and dc signals. If the input is a slowly-varying dc voltage, the output of the AD636 will track the input exactly. At higher frequencies, the average output of the AD636 will approach the rms value of the input signal. The actual output of the AD636 will differ from the ideal output by a dc (or average) error and some amount of ripple, as demonstrated in Figure 4.

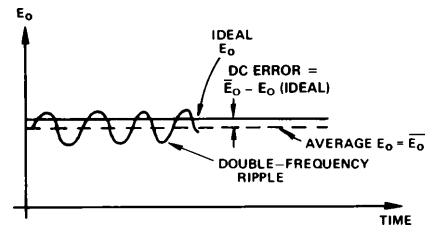

Figure 4. Typical Output Waveform for Sinusoidal Input

The dc error is dependent on the input signal frequency and the value of  $C_{AV}$ . Figure 5 can be used to determine the minimum value of  $C_{AV}$  which will yield a given % dc error above a given frequency using the standard rms connection.

The ac component of the output signal is the ripple. There are two ways to reduce the ripple. The first method involves using a large value of  $C_{AV}$ . Since the ripple is inversely proportional to  $C_{AV}$ , a tenfold increase in this capacitance will effect a tenfold reduction in ripple. When measuring waveforms with high crest factors, (such as low duty cycle pulse trains), the averaging time constant should be at least ten times the signal period. For example, a 100 Hz pulse rate requires a 100 ms time constant, which corresponds to a 4  $\mu$ F capacitor (time constant = 25 ms per  $\mu$ F).

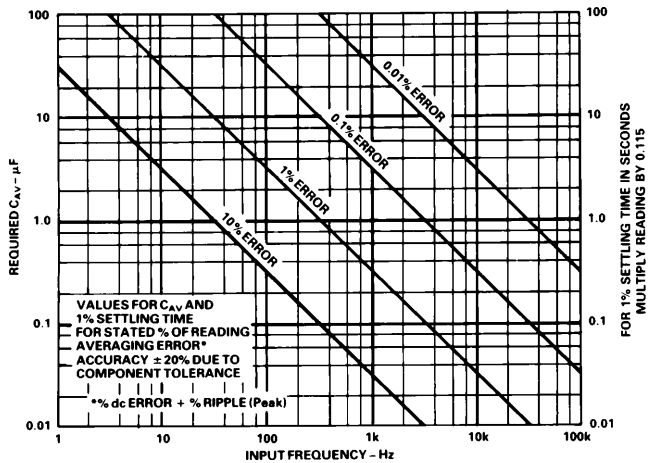

Figure 5. Error/Settling Time Graph for Use with the Standard rms Connection

The primary disadvantage in using a large  $C_{AV}$  to remove ripple is that the settling time for a step change in input level is increased proportionately. Figure 5 shows the relationship between  $C_{AV}$  and 1% settling time is 115 milliseconds for each microfarad of  $C_{AV}$ . The settling time is twice as great for decreasing signals as for increasing signals (the values in Figure 5 are for decreasing signals). Settling time also increases for low signal levels, as shown in Figure 6.

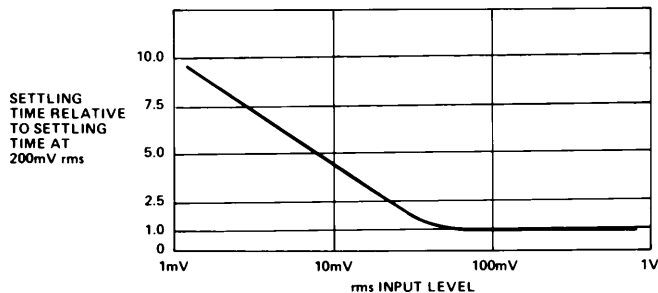

Figure 6. Settling Time vs. Input Level

A better method for reducing output ripple is the use of a "post-filter." Figure 7 shows a suggested circuit. If a single pole filter is used ( $C_3$  removed,  $R_X$  shorted), and  $C_2$  is approximately 5 times the value of  $C_{AV}$ , the ripple is reduced as shown in Figure 8, and settling time is increased. For example, with  $C_{AV} = 1 \mu F$  and  $C_2 = 4.7 \mu F$ , the ripple for a 60 Hz input is reduced from 10% of reading to approximately 0.3% of reading. The settling time, however, is increased by approximately a factor of 3. The values of  $C_{AV}$  and  $C_2$  can therefore be reduced to permit faster settling times while still providing substantial ripple reduction.

The two-pole post-filter uses an active filter stage to provide even greater ripple reduction without substantially increasing the settling times over a circuit with a one-pole filter. The values of  $C_{AV}$ ,  $C_2$ , and  $C_3$  can then be reduced to allow extremely fast settling times for a constant amount of ripple. Caution should be exercised in choosing the value of  $C_{AV}$ , since the dc error is dependent upon this value and is independent of the post filter.

For a more detailed explanation of these topics refer to the *RMS-to-DC Conversion Application Guide, 2nd Edition*, available from Analog Devices.

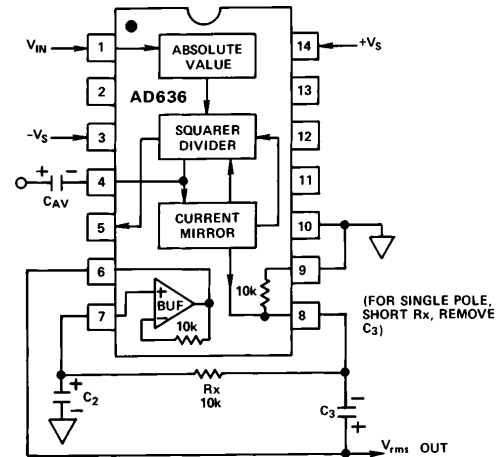

Figure 7. 2 Pole "Post" Filter

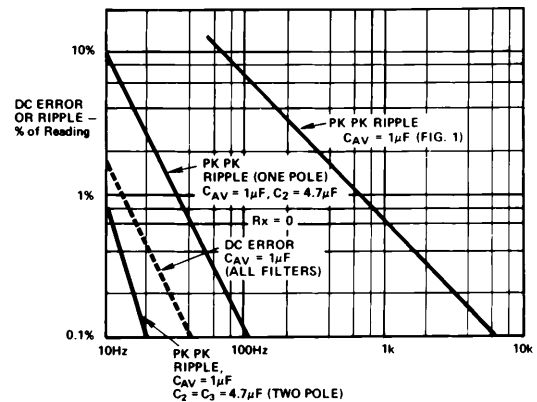

Figure 8. Performance Features of Various Filter Types

**RMS MEASUREMENTS**

**AD636 PRINCIPLE OF OPERATION**

The AD636 embodies an implicit solution of the rms equation that overcomes the dynamic range as well as other limitations inherent in a straightforward computation of rms. The actual computation performed by the AD636 follows the equation:

$$V_{rms} = Avg. \left[ \frac{V_{IN}^2}{V_{rms}} \right]$$

Figure 9 is a simplified schematic of the AD636; it is subdivided into four major sections: absolute value circuit (active rectifier), squarer/divider, current mirror, and buffer amplifier. The input voltage,  $V_{IN}$ , which can be ac or dc, is converted to a unipolar current  $I_1$ , by the active rectifier  $A_1, A_2$ .  $I_1$  drives one input of the squarer/divider, which has the transfer function:

$$I_4 = \frac{I_1^2}{I_3}$$

The output current,  $I_4$ , of the squarer/divider drives the current mirror through a low-pass filter formed by  $R_1$  and the externally connected capacitor,  $C_{AV}$ . If the  $R_1, C_{AV}$  time constant is much greater than the longest period of the input signal, then  $I_4$  is effectively averaged. The current mirror returns a current  $I_3$ , which equals  $Avg. [I_4]$ , back to the squarer/divider to complete the implicit rms computation. Thus:

$$I_4 = Avg. \left[ \frac{I_1^2}{I_4} \right] = I_1 rms$$

# AD636

The current mirror also produces the output current,  $I_{OUT}$ , which equals  $2I_4$ .  $I_{OUT}$  can be used directly or converted to a voltage with  $R_2$  and buffered by  $A_4$  to provide a low impedance voltage output. The transfer function of the AD636 thus results:

$$V_{OUT} = 2 R_2 I_{rms} = V_{IN} \text{ rms}$$

The dB output is derived from the emitter of  $Q_3$ , since the voltage at this point is proportional to  $-\log V_{IN}$ . Emitter follower,  $Q_5$ , buffers and level shifts this voltage, so that the dB output voltage is zero when the externally supplied emitter current ( $I_{REF}$ ) to  $Q_5$  approximates  $I_3$ .

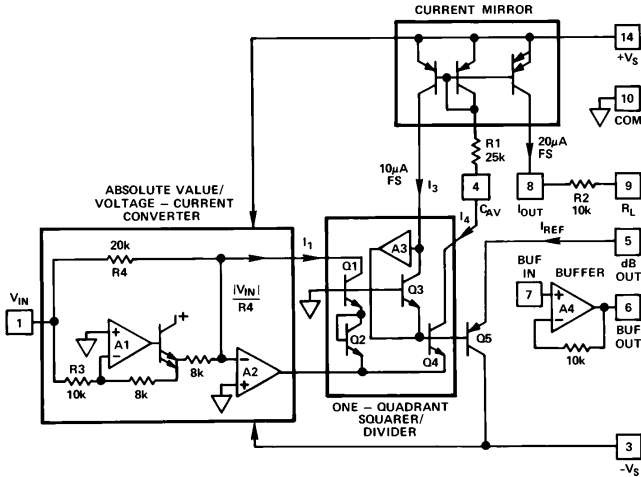

Figure 9. Simplified Schematic

## THE AD636 BUFFER AMPLIFIER

The buffer amplifier included in the AD636 offers the user additional application flexibility. It is important to understand some of the characteristics of this amplifier to obtain optimum performance. Figure 10 shows a simplified schematic of the buffer.

Since the output of an rms-to-dc converter is always positive, it is not necessary to use a traditional complementary Class AB output stage. In the AD636 buffer, a Class A emitter follower is used instead. In addition to excellent positive output voltage swing, this configuration allows the output to swing fully down to ground in single-supply applications without the problems associated with most IC operational amplifiers.

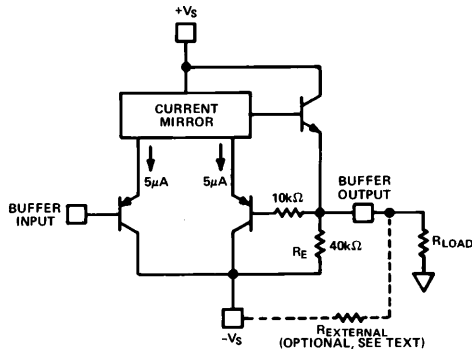

Figure 10. AD636 Buffer Amplifier Simplified Schematic

When this amplifier is used in dual-supply applications as an input buffer amplifier driving a load resistance referred to ground, steps must be taken to insure an adequate negative voltage swing. For negative outputs, current will flow from the load resistor through the 40 kΩ emitter resistor, setting up a voltage divider between  $-V_S$  and ground. This reduced effective  $-V_S$ , will

limit the available negative output swing of the buffer. Addition of an external resistor in parallel with  $R_E$  alters this voltage divider such that increased negative swing is possible.

Figure 11 shows the value of  $R_{EXTERNAL}$  for a particular ratio of  $V_{PEAK}$  to  $-V_S$  for several values of  $R_{LOAD}$ . Addition of  $R_{EXTERNAL}$  increases the quiescent current of the buffer amplifier by an amount equal to  $R_{EXT}/-V_S$ . Nominal buffer quiescent current with no  $R_{EXTERNAL}$  is 30  $\mu A$  at  $-V_S = -5 V$ .

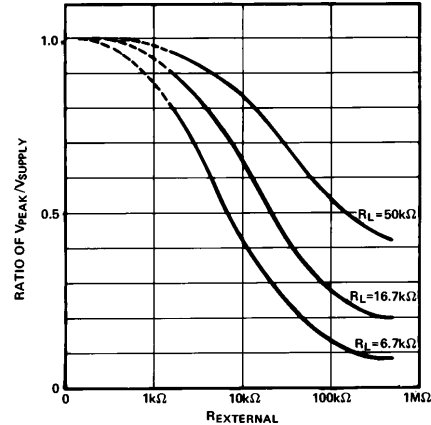

Figure 11. Ratio of Peak Negative Swing to  $-V_S$  vs.  $R_{EXTERNAL}$  for Several/Load Resistances

## FREQUENCY RESPONSE

The AD636 utilizes a logarithmic circuit in performing the implicit rms computation. As with any log circuit, bandwidth is proportional to signal level. The solid lines in the graph below represent the frequency response of the AD636 at input levels from 1 millivolt to 1 volt rms. The dashed lines indicate the upper frequency limits for 1%, 10%, and  $\pm 3$  dB of reading additional error. For example, note that a 1 volt rms signal will produce less than 1% of reading additional error up to 220 kHz. A 10 millivolt signal can be measured with 1% of reading additional error (100  $\mu V$ ) up to 14 kHz.

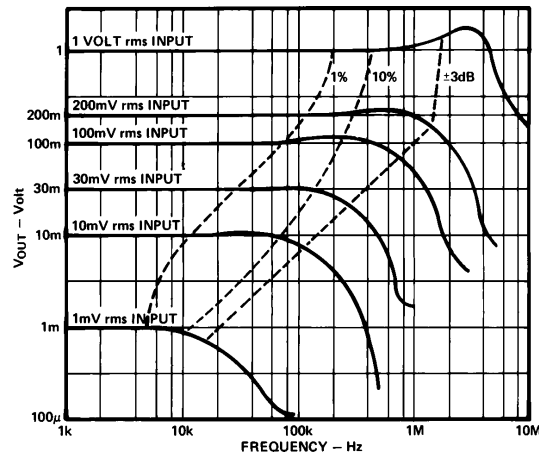

Figure 12. AD636 Frequency Response

## AC MEASUREMENT ACCURACY AND CREST FACTOR

Crest factor is often overlooked in determining the accuracy of an ac measurement. Crest factor is defined as the ratio of the peak signal amplitude to the rms value of the signal ( $C.F. = V_p/V_{rms}$ ). Most common waveforms, such as sine and triangle waves, have relatively low crest factors ( $<2$ ). Waveforms which

resemble low duty cycle pulse trains, such as those occurring in switching power supplies and SCR circuits, have high crest factors. For example, a rectangular pulse train with a 1% duty cycle has a crest factor of 10 ( $C.F. = 1/\sqrt{\eta}$ ).

Figure 13 is a curve of reading error for the AD636 for a 200 mV rms input signal with crest factors from 1 to 7. A rectangular pulse train (pulse width 200  $\mu$ s) was used for this test since it is the worst-case waveform for rms measurement (all the energy is contained in the peaks). The duty cycle and peak amplitude were varied to produce crest factors from 1 to 7 while maintaining a constant 200 mV rms input amplitude.

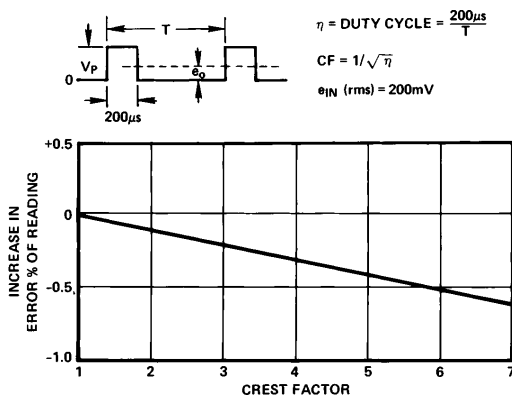

Figure 13. Error vs. Crest Factor

### A COMPLETE AC DIGITAL VOLTMETER

Figure 14 shows a design for a complete low power ac digital voltmeter circuit based on the AD636. The 10 M $\Omega$  input attenuator allows full-scale ranges of 200 mV, 2 V, 20 V and 200 V rms. Signals are capacitively coupled to the AD636 buffer amplifier, which is connected in an ac bootstrapped configuration to minimize loading. The buffer then drives the 6.7 k $\Omega$  input impedance of the AD636. The COM terminal of the ADC chip provides the false ground required by the AD636 for single supply operation. An AD589 1.2 volt reference diode is used to provide a stable 100 millivolt reference for the ADC in the linear rms mode; in the dB mode, a 1N4148 diode is inserted in series to provide correction for the temperature coefficient of the dB scale factor. Calibration of the meter is done by first adjusting offset pot R17 for a proper zero reading, then adjusting the R13 for an accurate readout at full scale.

Calibration of the dB range is accomplished by adjusting R9 for the desired 0 dB reference point, then adjusting R14 for the desired dB scale factor (a scale of 10 counts per dB is convenient).

Total power supply current for this circuit is typically 2.8 mA using a 7106-type ADC.

### A LOW POWER, HIGH INPUT IMPEDANCE dB METER Introduction

The portable dB meter circuit featured here combines the functions of the AD636 rms converter, the AD589 voltage reference, and a  $\mu$ A776 low power operational amplifier. This meter offers excellent bandwidth and superior high and low level accuracy while consuming minimal power from a standard 9 volt transistor radio battery.

In this circuit, the built-in buffer amplifier of the AD636 is used as a "bootstrapped" input stage increasing the normal 6.7 k $\Omega$  input Z to an input impedance of approximately 10<sup>10</sup> $\Omega$ .

### Circuit Description

The input voltage,  $V_{IN}$ , is ac coupled by C4 while resistor R8, together with diodes D1, and D2, provide high input voltage protection.

The buffer's output, Pin 6, is ac coupled to the rms converter's input (Pin 1) by capacitor C2. Resistor, R9, is connected between the buffer's output, a Class A output stage, and the negative output swing. Resistor R1, is the amplifier's "bootstrapping" resistor.

With this circuit, single supply operation is made possible by setting "ground" at a point between the positive and negative sides of the battery. This is accomplished by sending 250  $\mu$ A from the positive battery terminal through resistor R2, then through the 1.2 volt AD589 bandgap reference, and finally back to the negative side of the battery via resistor R10. This sets ground at 1.2 volts +3.18 volts ( $250 \mu\text{A} \times 12.7 \text{k}\Omega$ ) = 4.4 volts below the positive battery terminal and 5.0 volts ( $250 \mu\text{A} \times 20 \text{k}\Omega$ ) above the negative battery terminal. Bypass capacitors C3 and C5 keep both sides of the battery at a low ac impedance to ground. The AD589 bandgap reference establishes the 1.2 volt regulated reference voltage which together with resistor R3 and trimming potentiometer R4 set the zero dB reference current  $I_{REF}$ .

### Performance Data

0 dB Reference Range = 0 dBm (770 mV) to -20 dBm (77 mV) rms

0 dBm = 1 milliwatt in 600  $\Omega$

Input Range (at  $I_{REF} = 770 \text{ mV}$ ) = 50 dBm

Input Impedance = approximately 10<sup>10</sup>  $\Omega$

$V_{SUPPLY}$  Operating Range +5 V dc to +20 V dc

$I_{QUIESCENT} = 1.8 \text{ mA}$  typical

Accuracy with 1 kHz sine wave and 9 volt dc supply:

0 dB to -40 dBm  $\pm 0.1 \text{ dBm}$

0 dBm to -50 dBm  $\pm 0.15 \text{ dBm}$

+10 dBm to -50 dBm  $\pm 0.5 \text{ dBm}$

### Frequency Response $\pm 3 \text{ dBm}$ :

Input

0 dBm = 5 Hz to 380 kHz

-10 dBm = 5 Hz to 370 kHz

-20 dBm = 5 Hz to 240 kHz

-30 dBm = 5 Hz to 100 kHz

-40 dBm = 5 Hz to 45 kHz

-50 dBm = 5 Hz to 17 kHz

### Calibration

1. First calibrate the zero dB reference level by applying a 1 kHz sine wave from an audio oscillator at the desired zero dB amplitude. This may be anywhere from zero dBm (770 mV rms - 2.2 volts p-p) to -20 dBm (77 mV rms 220 mV - p-p). Adjust the  $I_{REF}$  cal trimmer for a zero indication on the analog meter.
2. The final step is to calibrate the meter scale factor or gain. Apply an input signal -40 dB below the set zero dB reference and adjust the scale factor calibration trimmer for a 40  $\mu$ A reading on the analog meter.

The temperature compensation resistors for this circuit may be purchased from: *Tel Labs Inc.*, 154 Harvey Road, P.O. Box 375, Londonderry, NH 03053, Part #Q332A 2 k $\Omega$  1% +3500 ppm/ $^{\circ}$ C or from *Precision Resistor Company*, 109 U.S. Highway 22, Hillside, NJ 07205, Part #PT146 2 k $\Omega$  1% +3500 ppm/ $^{\circ}$ C.

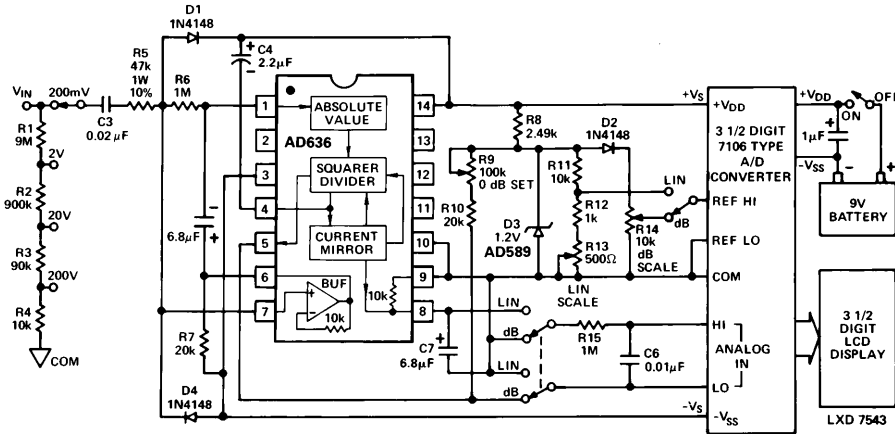
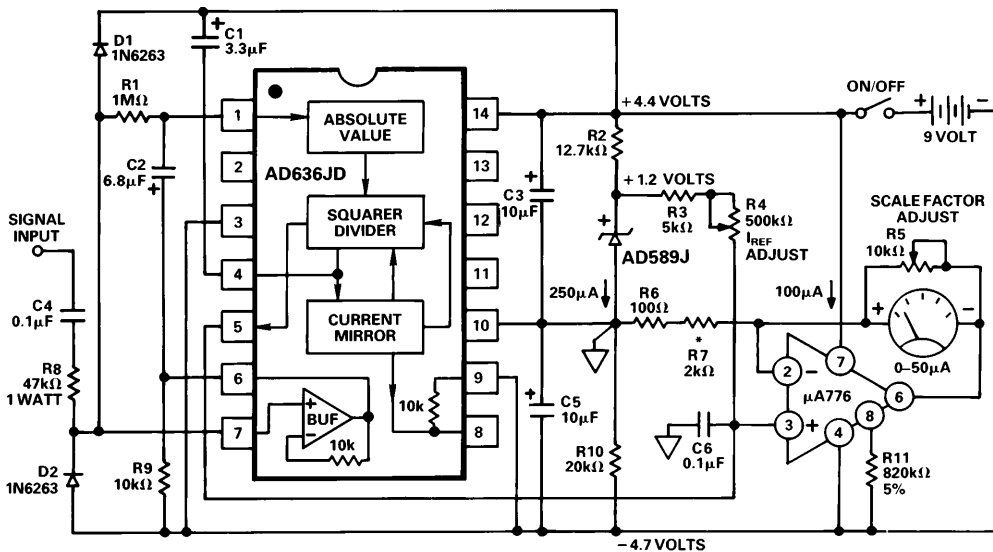

Figure 14. A Portable, High Z Input, RMS DPM and dB Meter Circuit



ALL RESISTORS 1/4 WATT 1% METAL FILM UNLESS OTHERWISE STATED EXCEPT  
 \* WHICH IS 2kΩ + 3500ppm 1% TC RESISTOR.

Figure 15. A Low Power, High Input Impedance dB Meter

OUTLINE DIMENSIONS

Dimensions shown in inches and (mm).

D Package (TO-116)

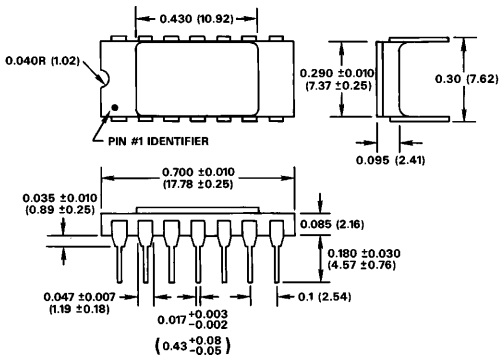

H Package (TO-100)

