

Preliminary Technical Data AD5532/64

FEATURES

- Infinite Hold Capability with No Droop
- Single Input, 32/64 channels of Output
- Input/Output Transfer Function Linearity of $\pm 0.012\%$ max
- Per-Channel Acquisition time of 16 μ s max
- Input Voltage: 0 to +3V
- Output Voltage Span: 10.5V
- e.g. -3V to +7.5V
- 2.5V to +7V
- Power-On Reset

APPLICATIONS

- Level Setting
- Instrumentation
- Automatic Test Equipment
- Control Systems
- Data Acquisition
- Low Cost I/O

GENERAL DESCRIPTION

The AD5532/64 combines a 32/64 channel voltage translation function with an infinite output hold capability. An analog input voltage on the common input pin, V_{IN} , is sampled and its digital representation transferred to a chosen DAC register. The output of this DAC is updated to reflect the new contents of the DAC register. Channel selection is accomplished via the parallel address inputs A5-A0 or via the serial input port. The device is operated from +5V, ± 12 V to ± 15 V supplies and requires a stable +3V reference on REF IN pins as well as an offset voltage on OFFS_IN. The AD5532/64 is available in a 119-lead BGA package.

PRODUCT HIGHLIGHTS

1. No Droop; Infinite Hold Capability
2. Typically $\pm 0.006\%$ transfer function linearity between Input and Output.
3. 32/64 14-bit DACs in one package, guaranteed monotonic with 9-bit linearity.
3. The AD5532/64 is available in a 119-lead BGA package with a bump pitch of 1.27mm and a body size of 14mm by 22mm.

FUNCTIONAL BLOCK DIAGRAM

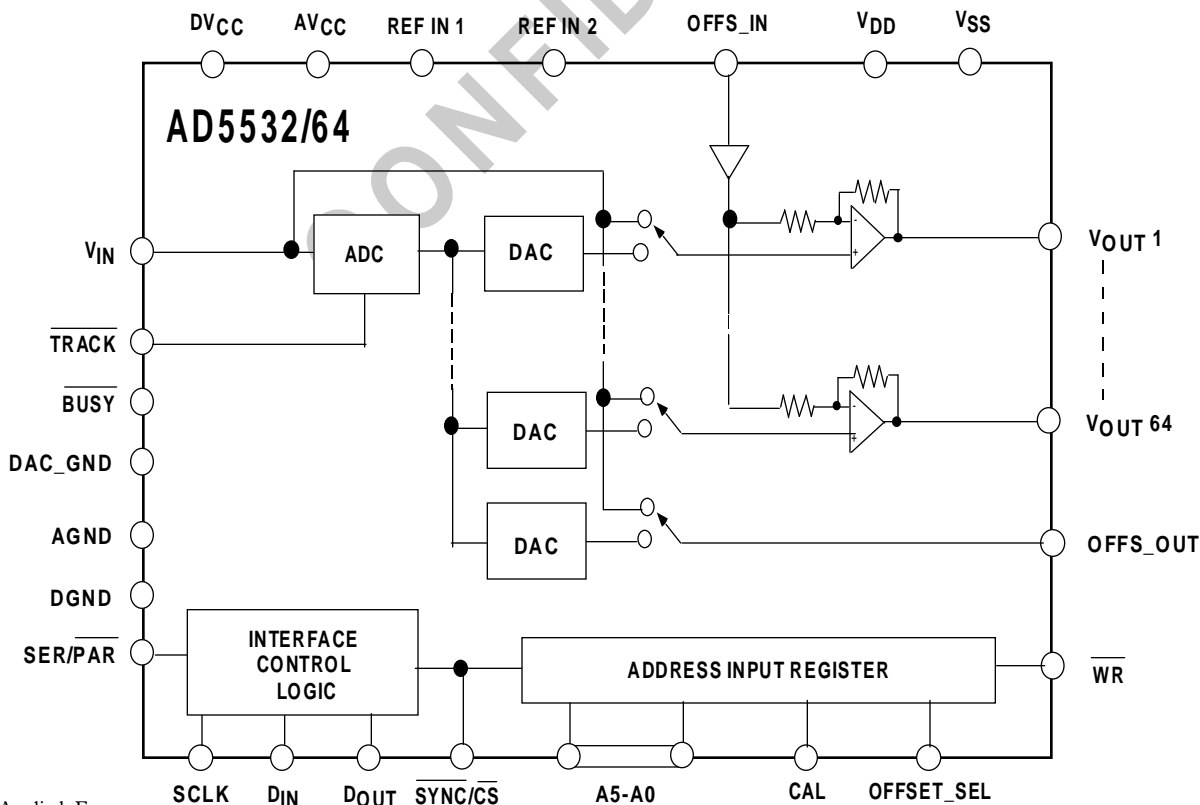

Patents Applied For

Information furnished by Analog Devices is believed to be accurate and reliable. However, no responsibility is assumed by Analog Devices for its use, nor for any infringements of patents or other rights of third parties which may result from its use. No license is granted by implication or otherwise under any patent or patent rights of Analog Devices.

One Technology Way, P.O. Box 9106, Norwood, MA 02062-9106, USA
 Tel: 781/329-4700
 Fax: 781/326-8703

World Wide Web: www.analog.com

Prelim D3 7/98

AD5532/64-SPECIFICATIONS

$V_{DD} = +10.8V$ to $+16.5V$, $V_{SS} = -10.8V$ to $-16.5V$; $AV_{CC} = +4.75V$ to $+5.25V$;
 $DV_{CC} = +2.7V$ to $+5.25V$; $AGND = DGND = DAC_GND = 0V$; All specifications T_{MIN} to T_{MAX} unless otherwise noted.

Mode 1 - SHA Mode

Parameter ¹	B Version ²	Units	Conditions/Comments
ANALOG CHANNEL V_{IN} to V_{OUT} Linearity	± 0.012	% max	Typically $\pm 0.006\%$ (after gain and offset adjustment)
Offset Error	± 60	mV max	See Figure 1 (page 8)
Gain Error	± 3	% max	
Channel-to-Channel Matching	TBD	% typ	
ANALOG INPUT (V_{IN}) Input Voltage Range Input Current	0 to +3 100 6.4	V nA max μA max	Nominal Input Range V_{IN} being acquired on one channel V_{IN} being acquired on all 64 channels simultaneously - Cal Mode
Input Capacitance	50	pF typ	
ANALOG INPUT (OFFS_IN) Input Current	100	nA max	
REFERENCE INPUTS Nominal Input Voltage Input Voltage Range Input Current	+3.0 +2.85/+3.15 50	V V min/max nA max	
ANALOG OUTPUTS (V_{OUT} 1-64) Output Temp Coeff Output Impedance Output Range Maximum Output Current Maximum Capacitive Load Output Noise Short-Circuit Current Output PSRR DC Crosstalk	25 750 $V_{SS} + 3 / V_{DD} - 3$ 500 15 250 10 -70 -70 TBD	ppm/ $^{\circ}C$ typ Ω typ V min/max μA typ nF max μV rms mA typ dB dB μV typ	1MHz Bandwidth V_{DD} varied $\pm 5\%$. V_{SS} varied $\pm 5\%$
ANALOG OUTPUT (OFFS_OUT) Output Temp Coeff Output Impedance Output Range Output Noise Maximum Output Current Maximum Capacitive Load Short-Circuit Current Output PSRR DC Crosstalk	20 1.0 0 / +REF IN 100 10 100 10 -70 TBD	ppm/ $^{\circ}C$ typ k Ω typ V min/max μV rms μA typ pF typ mA typ dB typ μV typ	1MHz Bandwidth Source Current Sink Current AV_{CC} varied $\pm 5\%$
DIGITAL INPUTS Input Current Input Low Voltage Input High Voltage Input Hysteresis (SCLK only) Input Capacitance	± 10 0.8 0.4 2.0 200 10	μA max V max V max V min mV typ pF max	$DV_{CC} = 5V \pm 5\%$ $DV_{CC} = 3V \pm 10\%$

AD5532/64-SPECIFICATIONS

$V_{DD} = +10.8V$ to $+16.5V$, $V_{SS} = -10.8V$ to $-16.5V$; $AV_{CC} = +4.75V$ to $+5.25V$; $DV_{CC} = +2.7V$ to $+5.25V$; $AGND = DGND = DAC_GND = 0V$; All specifications T_{MIN} to T_{MAX} unless otherwise noted.

Mode 1 - SHA Mode (cont.)

Parameter ¹	B Version ²	Units	Conditions/Comments
DIGITAL OUTPUTS (BUSY, D_{OUT})			
Output Low Voltage	0.4	V max	DV _{CC} = 5V. Sinking TBD mA
Output High Voltage	4.0	V min	DV _{CC} = 5V. Sourcing TBD μ A
Output Low Voltage	0.4	V max	DV _{CC} = 3V. Sinking TBD mA
Output High Voltage	2.4	V min	DV _{CC} = 3V. Sourcing TBD μ A
Floating-State Leakage Current ⁴	TBD	μ A max	
Floating-State Input Capacitance ⁴	TBD	pF max	
POWER REQUIREMENTS			
Power-Supply Voltages			
V _{DD}	+10.8/+16.5	V min/max	
V _{SS}	-10.8/-16.5	V min/max	
AV _{CC}	+4.75/+5.25	V min/max	
DV _{CC}	+2.7/+5.25	V min/max	
Power-Supply Currents ⁵			
I _{DD}	22	mA typ	
I _{SS}	22	mA typ	
AI _{CC}	44	mA typ	
DI _{CC}	< 1	mA max	
Power Dissipation ⁵	880	mW typ	
AC CHARACTERISTICS			
AC Crosstalk	TBD	nV-s typ	Low Capacitive load Acquire V _{IN} to $\pm 0.012\%$ accuracy
Output Settling Time	1	μ s typ	
Acquisition Time	16	μ s max	
Slew Rate	1	V/ μ s typ	
Digital Feedthrough	TBD	nV-s typ	
Digital Crosstalk	TBD	nV-s typ	
TRACK MODE			
Output PSRR	TBD	dB	V _{DD} varied $\pm 5\%$.
	TBD	dB	V _{SS} varied $\pm 5\%$
Bandwidth	TBD	kHz typ	

NOTES:

¹See Terminology

²B Version: Industrial temperature range -40°C. to +85°C.

³Guaranteed by design and characterisation, not production tested

⁴D_{OUT} only

⁵Outputs Unloaded. All figures are for the AD5564. The numbers for AD5532 are approx 50% of these.

Specifications subject to change without notice

AD5532/64-SPECIFICATIONS

$V_{DD} = +10.8V$ to $+16.5V$, $V_{SS} = -10.8V$ to $-16.5V$; $AV_{CC} = +4.75V$ to $+5.25V$; $DV_{CC} = +2.7V$ to $+5.25V$; $AGND = DGND = DAC_GND = 0V$; All specifications T_{MIN} to T_{MAX} unless otherwise noted.

Mode 2 - DAC Mode

Parameter ¹	B Version ²	Units	Conditions/Comments
DC PERFORMANCE			
Resolution	14	Bits	Guaranteed Monotonic
Integral Nonlinearity (INL)	TBD	% of FSR typ	
Differential Nonlinearity (DNL)	± 1	LSB max	
Offset Error	TBD	mV max	
Gain Error	TBD	% max	
Full-Scale Error	TBD	mV max	
Offset Error Temp Coeff	TBD	$\mu V/^{\circ}C$ typ	
Gain Error Temp Coeff	TBD	$\mu V/^{\circ}C$ typ	
Channel-to-Channel Matching	TBD	% max	
AC CHARACTERISTICS			
Output Settling Time	TBD	μs typ	
OFFS_IN Settling Time	TBD	μs typ	
Digital-to-Analog Glitch Impulse	TBD	nV-s typ	
Digital Crosstalk	TBD	nV-s typ	
Analog Crosstalk	TBD	nV-s typ	
Total Harmonic Distortion (THD)	TBD	dB typ	
Output Noise Spectral Density	TBD	$nV/(Hz)^{1/2}$ typ	

NOTES:

¹See Terminology

²B version: Industrial temperature range $-40^{\circ}C$. to $+85^{\circ}C$.

³Guaranteed by design and characterisation, not production tested

Specifications subject to change without notice

Timing Characteristics

Serial Interface

Parameter ¹	Limit at T_{MIN} , T_{MAX} (B Version)	Units	Conditions/Comments
t_1	25	ns min	SCLK High Pulse Width
t_2	25	ns min	SCLK Low Pulse Width
t_3	5	ns min	<u>SYNC</u> Falling Edge to SCLK Falling Edge Setup Time
t_4	TBD	ns min	<u>SYNC</u> Low Time
t_5	10	ns min	D_{IN} Setup Time
t_6	5	ns min	D_{IN} Hold Time
t_7	5	ns min	<u>SYNC</u> Falling Edge to SCLK Rising Edge Setup Time
t_8^2	10	ns max	SCLK Rising Edge to D_{OUT} Valid
t_9^2	20	ns max	SCLK Falling Edge to D_{OUT} High Impedance

NOTES:

¹See Interface Timing Diagrams on following pages

²These numbers are measured with the load circuit of Figure x

AD5532/64 Prelim Technical Information

Parallel Interface

Parameter ¹	Limit at T_{MIN} , T_{MAX} (B Version)	Units	Conditions/Comments
t_1	0	ns min	\overline{CS} to \overline{WR} Setup Time
t_2	0	ns min	\overline{CS} to \overline{WR} Hold Time
t_3	50	ns min	\overline{CS} Pulse Width Low
t_4	50	ns min	\overline{WR} Pulse Width Low
t_5	20	ns min	A5-A0, CAL, OFFS_SEL to \overline{WR} Setup Time
t_6	0	ns min	A5-A0, CAL, OFFS_SEL to \overline{WR} Hold Time

NOTES:

¹See Interface Timing Diagrams below

Parallel Interface Timing Diagram

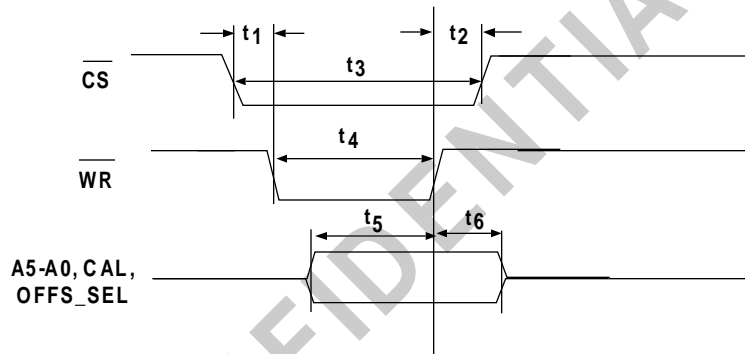

Serial Interface Timing Diagrams

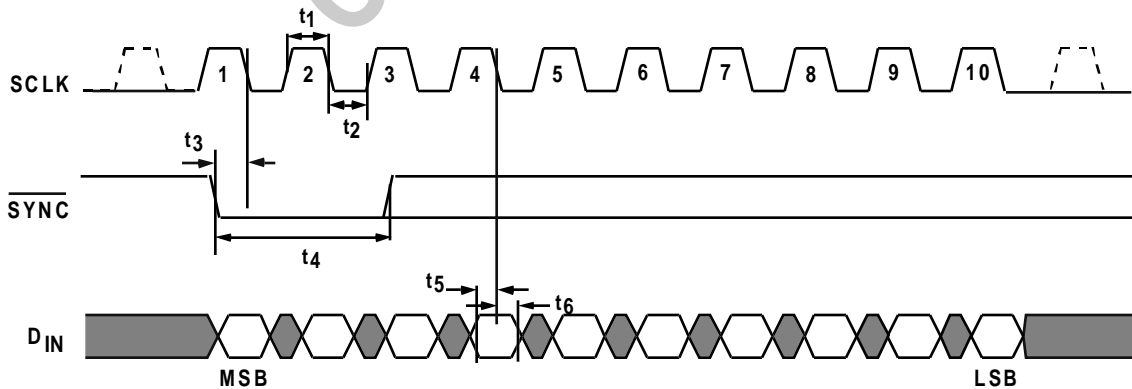

10-Bit Write (SHA Mode and Both Readback Modes)

AD5532/64 Prelim Technical Information

Serial Interface Timing Diagrams

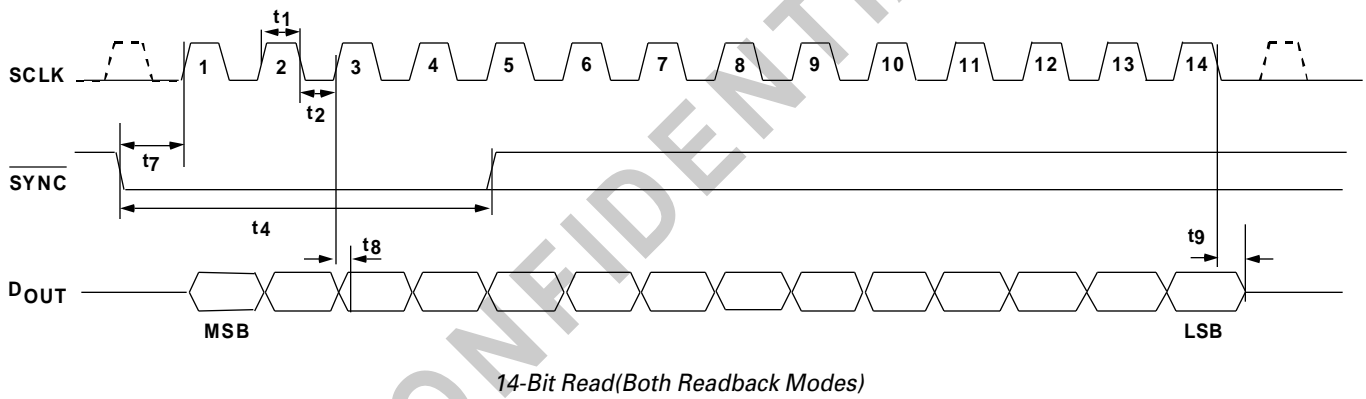
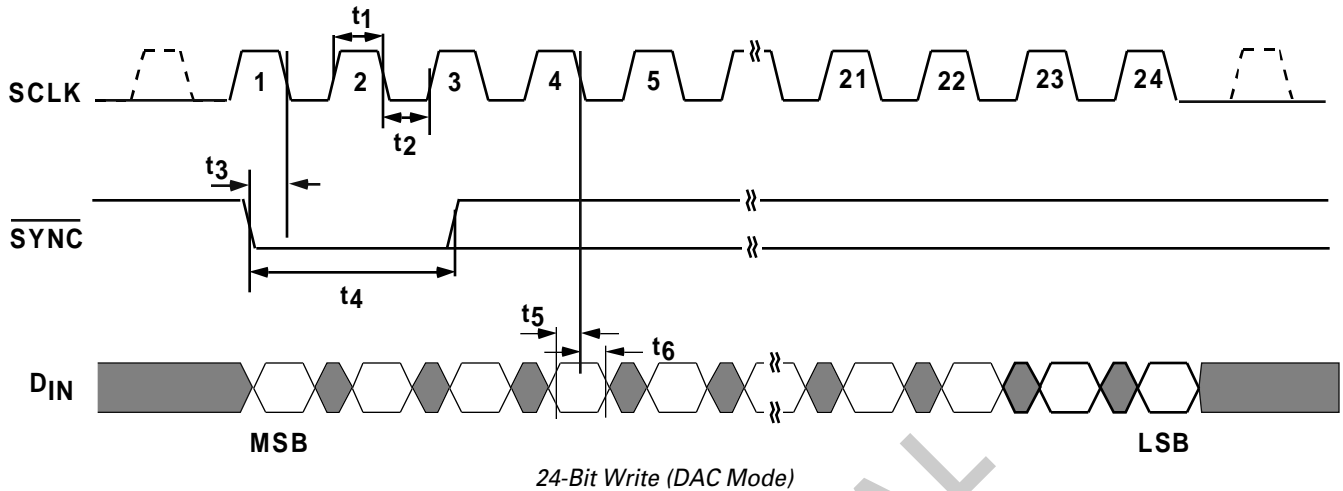

ABSOLUTE MAXIMUM RATINGS*

($T_A = +25^\circ\text{C}$ unless otherwise noted)

V_{DD} to AGND.....	-0.3V to +17V
V_{SS} to AGND.....	+0.3V to -17V
AV_{CC} to AGND, DAC_GND.....	-0.3V to +7V
DV_{CC} to DGND.....	-0.3V to +7V
Digital Inputs to DGND.....	-0.3V to $DV_{CC}+0.3V$
Digital Outputs to DGND.....	-0.3V to $DV_{CC}+0.3V$
REF IN to AGND, DAC_GND.....	-0.3V to +7V
V_{IN} to AGND, DAC_GND.....	-0.3V to +7V
$V_{OUT1-64}$, OFFS_OUT to AGND.....	$V_{SS}-0.3V$ to $V_{DD}+0.3V$
AGND to DGND.....	TBD

Short-Circuit Current.....	TBD mA
Operating Temperature Range	
Industrial (B Version).....	-40°C to $+85^\circ\text{C}$
Storage Temperature Range.....	-65°C to $+150^\circ\text{C}$
Junction Temperature (T_J max).....	$+150^\circ\text{C}$
BGA Package,	
Power Dissipation.....	$(T_J \text{ max} - T_A)/\theta_{JA}$ mW
θ_{JA} Thermal Impedance.....	TBD $^\circ\text{C}/\text{W}$
θ_{JC} Thermal Impedance.....	TBD $^\circ\text{C}/\text{W}$
Solder Ball Temperature, Soldering.....	TBD $^\circ\text{C}$.

NOTES:

¹Stresses above those listed under "Absolute Maximum Ratings" may cause permanent damage to the device. This is a stress rating only, and functional operation of the device at these or any other conditions above those listed in the operational sections of this specification is not implied. Exposure to absolute maximum rating conditions for extended periods may affect device reliability.

²Transient currents of up to 100mA will not cause SCR latch-up

CAUTION

ESD (electrostatic discharge) sensitive device. Electrostatic charges as high as 4000 V readily accumulate on the human body and test equipment and can discharge without detection. Although the AD5532/64 devices feature proprietary ESD protection circuitry, permanent damage may still occur on these devices if they are subjected to high energy electrostatic discharges. Therefore, proper ESD precautions are recommended to avoid performance degradation or loss of functionality.

AD5532/64 Prelim Technical Information

Terminology

SHA Mode

V_{IN} to V_{OUT} Linearity

This is a measure of the maximum deviation from a straight line passing through the endpoints of the V_{IN} vs. V_{OUT} transfer function. It is expressed as a percent of the full-scale span.

Offset Error

This is a measure of the output error when V_{IN} = 100mV. Ideally, with V_{IN}=100mV:

$$V_{OUT} = 350\text{mV} - 2.5 \cdot V_{OFFSET}$$

Offset error is a measure of the difference between V_{OUT} (actual) and V_{OUT} (ideal). It is expressed in mV.

Full-Scale Error

This is a measure of the output error when V_{IN} = V_{REF}. Ideally, with V_{IN}=V_{REF}:

$$V_{OUT} = 3.5 \cdot V_{REF} - 2.5 \cdot V_{OFFSET}$$

Full-scale error is a measure of the difference between V_{OUT} (actual) and V_{OUT} (ideal). It is expressed in mV.

Gain Error

This is a measure of the span error of the analog channel. It is the deviation in slope of the transfer function expressed as a percent of the full-scale span. It is calculated as:

$$\text{Gain Error} = \frac{\text{Full-Scale error} - \text{Offset Error}}{\text{Full-scale span}} \cdot 100$$

Channel-to-Channel Matching

This is a measure of the difference between V_{OUT} on any two channels if they acquire the same V_{IN}. It is expressed as a percent of the Full-scale span.

Output Temp Coefficient

This is a measure of the change in output with changes in temperature. It is expressed in $\mu\text{V}/^\circ\text{C}$.

Output PSRR

Power-Supply Rejection Ratio (PSRR) is a measure of the change in output for a change in supply voltage (V_{DD} and V_{SS}). It is expressed as percent change of output per percent change of supply. V_{DD} and V_{SS} are varied $\pm 5\%$. For the PSRR measurement of OFFS_OUT, the AV_{CC} supply is varied $\pm 5\%$.

DC Crosstalk

This the DC change in the output level of one channel in response to a full-scale change in the output of another channel. It is expressed in μV .

AC Crosstalk

This is the glitch that occurs on the output of one channel while another channel is acquiring. It is expressed in nV-secs.

Output Settling Time

This is the time taken from when BUSY goes high to when the output has settled to $\pm 0.012\%$ (± 0.5 LSB at 12 bits).

Acquisition Time

This is the time taken for the V_{IN} input to be acquired. It is the length of time that BUSY stays low.

Digital Feedthrough

This is a measure of the impulse injected into the analog outputs from the digital control inputs when the part is not being written to, i.e. CS/SYNC is high. The digital inputs are toggled between all 0s and all 1s. The area of the glitch is expressed in nV-secs.

Digital Crosstalk

This is the glitch impulse transferred to the analog output while a digital word is being written to the part. The area of the glitch is expressed in nV-secs.

TRACK Mode Bandwidth

When TRACK input is brought low, the input is not acquired. It is connected to the output buffer and the output voltage is:

$$V_{OUT} = 3.5 \cdot V_{IN} - 2.5 \cdot V_{OFFSET}$$

V_{IN} can, of course, be an AC waveform in which case the TRACK mode has a finite bandwidth. The bandwidth is the frequency at which the sinusoidal component at the output falls to 3dB below the sine wave at the input (ignoring the gain factor).

DAC Mode

Integral Nonlinearity (INL)

This is a measure of the maximum deviation from a straight line passing through the endpoints of the DAC transfer function. It is expressed as a percentage of Full-Scale span.

Differential Nonlinearity (DNL)

Differential Nonlinearity (DNL) is the difference between the measured change and the ideal 1 LSB change between any two adjacent codes. A specified DNL of ± 1 LSB maximum ensures monotonicity.

Offset Error

This is a measure of the output error with all zeroes loaded to the DAC. Ideally the output should be:

$$V_{OUT} = 350\text{mV} - 2.5 \cdot V_{OFFSET}$$

Offset error is a measure of the difference between V_{OUT} (actual) and V_{OUT} (ideal). It is expressed in mV.

Full-Scale Error

This is a measure of the output error with all ones loaded to the DAC. Ideally, the output should be:

$$V_{OUT} = 3.5 \cdot V_{REF} - 2.5 \cdot V_{OFFSET}$$

Full-scale error is a measure of the difference between V_{OUT} (actual) and V_{OUT} (ideal). It is expressed in mV.

Gain Error

This is a measure of the span error of the DAC. It is the deviation in slope of the transfer function expressed as a percent of the full-scale span. It is calculated as:

$$\text{Gain Error} = \frac{\text{Full-Scale error} - \text{Offset Error}}{\text{Full-scale span}} \cdot 100$$

AD5532/64 Prelim Technical Information

Channel-to-Channel Matching

This is a measure of the difference between V_{OUT} on any two DACs if they have the same coded loaded to them. It is expressed as a percent of the Full-scale span.

Output Settling Time

This is the time taken from when the last data bit is clocked into the DAC until the output has settled to within $\pm 0.012\%$ (± 0.5 LSB at 12 bits).

OFFS_IN Settling Time

This is the time taken from a step change in input voltage on OFFS_IN until the output has settled to within $\pm 0.012\%$ (± 0.5 LSB at 12 bits).

Digital-to-Analog Glitch Impulse

This is the impulse injected into the analog output when the code in the DAC register changes state. It is specified as the area of the glitch in nV-secs when the digital code is changed by 1 LSB at the major carry transition (01 1111 1111 1111 to 10 0000 0000 0000).

Digital Crosstalk

This is the glitch impulse transferred to the analog output while a DAC code is being written to the part. The area of the glitch is expressed in nV-secs.

Analog Crosstalk

This the glitch impulse transferred to the output of one DAC due to a full-scale change in the output of another DAC. The area of the glitch is expressed in nV-secs.

Total Harmonic Distortion

This is the difference between an ideal sine-wave and a digitally constructed one using the DAC. The THD is a measure of the harmonics and noise present on the DAC output. It is measured in dBs.

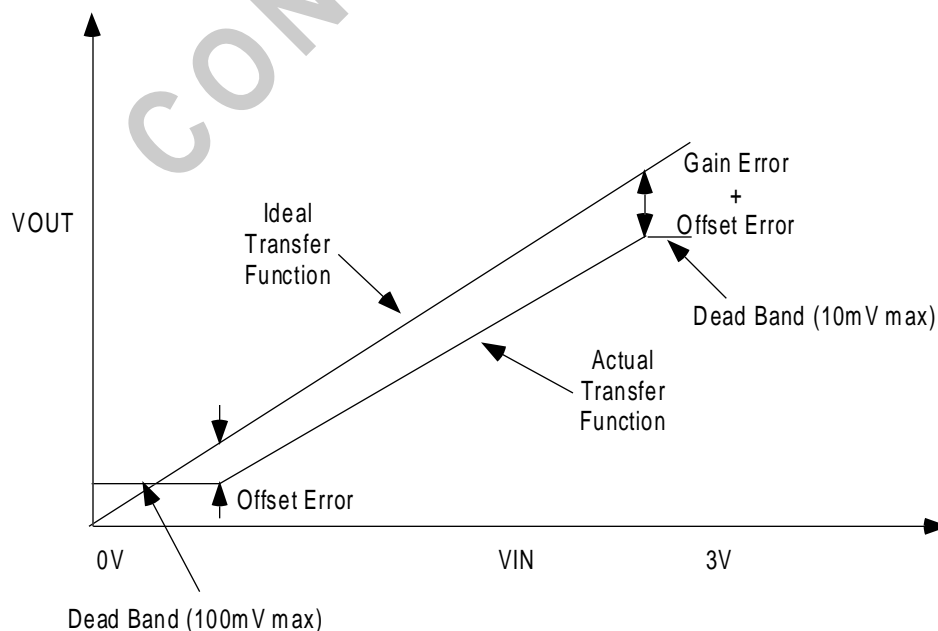

Figure 1. SHA Transfer Function

AD5532/64 Prelim Technical Information

PIN FUNCTION DESCRIPTION

PIN NUMBERS

Pin No.	Mnemonic	Function
	AGND (1-4)	4 Analog GND pins.
	AV _{CC} (1-4)	4 Analog supply pins. Voltage range from +4.75V to +5.25V.
	V _{DD} (1-8)	8 V _{DD} supply pins. Voltage range from +10.8V to +16.5V.
	V _{SS} (1-8)	8 V _{SS} supply pins. Voltage range from +10.8V to +16.5V.
	DGND (1-2)	2 Digital GND pins
	DV _{CC} (1-2)	2 Digital supply pins. Voltage range from +2.7V to +5.25V.
	DAC_GND (1-4)	Reference GND supply for all the DACs.
	REF IN 1	Reference voltage for channels 1-32
	REF IN 2	Reference voltage for channels 33-64
	V _{OUT} (1-64)	Analog output voltages from the 64 channels.
	V _{IN}	Analog input voltage
	A5-A0	Parallel Interface: 6 address pins for the 64 channels. A5=MSB of channel address, A0=LSB.
	CAL	Parallel Interface: Control input which allows all 64 channels to acquire V _{IN} simultaneously
	<u>CS</u> / <u>SYNC</u>	This pin is both the active low Chip Select pin for the parallel interface and the Frame Synchronisation pin for the serial interface.
	<u>WR</u>	Parallel Interface. Write pin. Active low. This is used in conjunction with the <u>CS</u> pin to address the device using the parallel interface.
	OFFSET_SEL	Offset Select pin. This is activated when writing to the DAC which will provide its output at OFFS_OUT pin.
	SCLK	Serial Clock input for serial interface
	D _{IN}	Data input for serial interface
	D _{OUT}	Output from the DAC registers for readback.
	<u>SER/PAR</u>	This pin allows the user to select whether the serial or parallel interface will be used. If the pin is tied low, the parallel interface will be used. If it is tied high, the serial interface will be used.
	OFFS_IN	Offset input. The user can supply a voltage here to offset the output span. OFFS_OUT can also be tied to this pin if the user wants to drive this pin with the Offset Channel.
	OFFS_OUT	Offset output. This is the acquired offset voltage which can be tied to OFFS_IN to offset the span.
	<u>BUSY</u>	This output tells the user when the input voltage is being acquired. It goes low during acquisition and returns high when the acquisition operation is complete.
	<u>TRACK</u>	If this input is held high, V _{IN} is acquired once the channel is addressed. While it is held low, the input to the gain/offset stage is switched directly to V _{IN} . The addressed channel begins to acquire V _{IN} on the rising edge of <u>TRACK</u> . See <u>TRACK</u> Input section for further information.

AD5532/64 Prelim Technical Information

Circuit Description

The AD5532/64 can be thought of as consisting of an ADC and 64 DACs in a single package. The input voltage V_{IN} is sampled and converted into a digital word. The digital result is loaded into one of the DAC registers and is converted (after the gain and offset in the output buffer) into an analog output voltage (V_{OUT1} - V_{OUT64}). Since the channel output voltage is effectively the output of a DAC there is no droop associated with it. As long as power is maintained to the device the output voltage will remain constant until this channel is addressed again.

To update a single channel's output voltage the required new voltage level is set up on the common input pin, V_{IN} . The desired channel is then addressed via the parallel port or the serial port. When the channel address has been loaded, provided TRACK is high, the circuit begins to acquire the correct code to load to the DAC in order that the DAC output matches the voltage on V_{IN} . At this stage the BUSY pin goes low and remains so until the acquisition is complete. The non-inverting input to the output buffer (gain and offset stage) is tied to V_{IN} during the acquisition period to avoid spurious outputs while the DAC acquires the correct code. This is completed in 16 us max. The BUSY pin goes high at this stage. Also at this time the updated DAC output assumes control of the output voltage. The output voltage of the DAC is connected to the non-inverting input of the output buffer. The held voltage will remain on the output pin indefinitely, without drooping, as long as power is maintained to the device.

On power-on, all the DACs, including the offset channel, are loaded with zeroes. The outputs of the DACs are at 0V and the outputs of the output buffers are at negative full-scale. If the OFFS_IN pin is driven by the on-board offset channel, the outputs V_{OUT1} to V_{OUT64} are also at 0V on power-on since OFFS_IN is 0V.

TRACK Input

In normal mode of operation, TRACK is held high and the channel begins to acquire when it is addressed. However, if TRACK is low when the channel is addressed then V_{IN} is switched to the output buffer and an acquisition on the channel will not occur until a rising edge of TRACK. At this stage the BUSY pin will go low until the acquisition is

complete at which point the DAC assumes control of the voltage to the output buffer and V_{IN} is free to change again without affecting this output value.

This is useful in an application where the user wants to ramp up V_{IN} until V_{OUT} reaches a particular level (Figure 1). V_{IN} doesn't need to be acquired continuously while it is ramping up. TRACK can be kept low and only when V_{OUT} has reached its desired voltage is TRACK brought high. At this stage, the acquisition of V_{IN} begins.

In the example shown, a desired voltage is required on the output of the pin driver. This voltage is represented by one input to a comparator. The microcontroller/microprocessor ramps up the input voltage on V_{IN} through a DAC. TRACK is kept low while the voltage on V_{IN} ramps up so that V_{IN} is not continually acquired. When the desired voltage is reached on the output of the pin driver, the comparator output switches. The $\mu C/\mu P$ then knows what code is required to be input in order to get the desired voltage at the DUT. The TRACK input is now brought high and the part begins to acquire V_{IN} . At this stage BUSY goes low until V_{IN} has been acquired. Then the output buffer is switched from V_{IN} to the output of the DAC.

Output Buffer Stage - Gain and Offset

The function of the output buffer stage is to translate the 0-3V output of the DAC to a useful range for ATE applications. This is done by gaining up the DAC output by 3.5 and offsetting the voltage by the voltage on OFFS_IN pin. The following table shows how the output range relates to the Offset voltage supplied by the user.

$$V_{OUT} = 3.5 * V_{DAC} - 2.5 * V_{OFFSET}$$

V_{DAC} is the output of the DAC and its range is 0- V_{REF} . V_{OFFSET} is the voltage at the OFFS_IN pin.

SAMPLE OUTPUT RANGES

V_{OFFSET} (V)	V_{DAC} (V)	V_{OUT} (V)
1	0 to 3	-2.5 to 8
0.5	0 to 3	-1.25 to 9.25

V_{OUT} is limited only by the headroom of the output amplifiers.

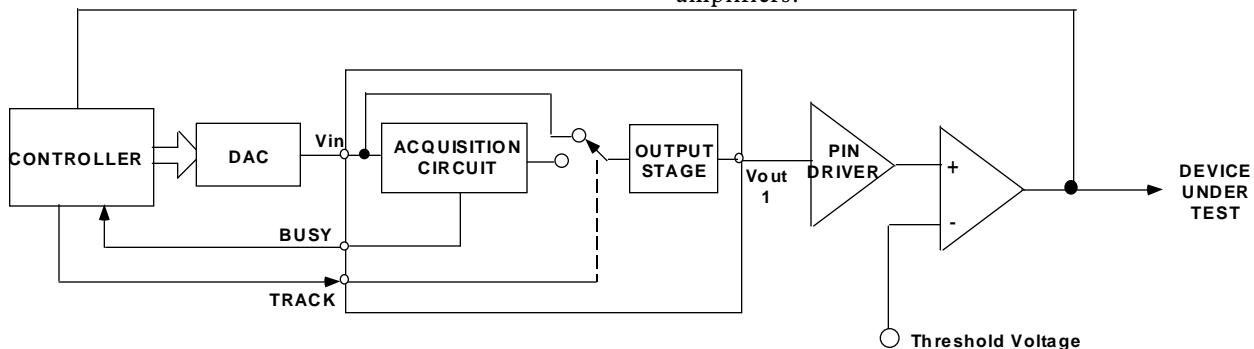

*Only one channel shown for simplicity
Typical ATE circuit using TRACK Input

AD5532/64 Prelim Technical Information

Offset Voltage Channel

The offset voltage can be supplied externally by the user or it can be supplied by an additional DAC on the part. The offset voltage channel is used just like any other channel. The required offset voltage is set up on V_{IN} and it is acquired by the DAC. The DAC output is connected directly to OFFS_OUT. This offset voltage is used as the offset voltage for the 64 output amplifiers.

Serial Interface

The serial interface is controlled by 4 pins.

SYNC, D_{IN}, SCLK: Standard 3-wire SPI interface pins. The **SYNC** pin is shared with the **CS** function of the parallel interface.

D_{OUT}: Data Out pin for reading back the contents of the DAC registers.

The **SER/PAR** pin must also be tied high to enable the serial interface and to disable the parallel interface.

Mode bits: There are 4 different modes of operation. See below for descriptions.

Cal bit: This is used as a calibration instruction. When this is active, all 64 channels acquire V_{IN} simultaneously.

Offset_Sel bit: Used to address the offset voltage control channel.

A5-A0: Used to address any one of the 64 channels (A5 = MSB of address, A0=LSB).

DB13-DB0: These are used to write a 14-bit word into the addressed DAC register. Clearly, this is only valid when in DAC mode.

The AD5532/64 can be used in 4 different modes of operation. These modes are set by two Mode bits, the first 2 bits in the serial word.

MODES OF OPERATION

Mode Bit 1	Mode Bit 2	Operating Mode
0	0	SHA Mode
0	1	DAC Mode
1	0	Acquire and Readback
1	1	Readback

1) SHA Mode:

Standard mode where a channel is addressed and that channel acquires the voltage on V_{IN} . This mode requires a 10-bit write (see figure below) to address the relevant channel (V_{OUT1} - V_{OUT64} , Offset Channel or all channels).

2) DAC Mode:

In this mode, a particular DAC register can be written to directly. This mode requires the 10-bit write from the SHA mode plus an extra 14 bits to write to the 14-bit register of the DAC. Any one of the 64 DAC registers may be written to individually or they can all be loaded simultaneously.

3) Acquire and Readback Mode:

This mode allows the user to read back the data in a particular DAC register. The relevant DAC is addressed (10-bit write as with SHA mode) and V_{IN} is acquired.

However, on the next falling edge of **SYNC**, the data in the relevant DAC register is clocked out onto the **D_{OUT}** line in a 14-bit serial format.

4) Readback

Again, this is a readback mode but no acquisition is performed. The relevant DAC is addressed (10-bit write) and on the next falling edge of **SYNC**, the data in the relevant DAC register is clocked out onto the **D_{OUT}** line in a 14-bit serial format.

The serial write and read words can be seen in the figures below.

Digital Readback

This feature allows the user to readback the DAC register code of any of the DACs. This is useful if the system has been calibrated and the user wants to know what code in the DAC corresponds to a desired voltage on V_{OUT} . If the user requires this voltage again, all he needs to do is to input the code directly to the DAC register without going through the acquisition sequence. The user can readback the DAC register contents through the serial interface and can write directly to the DAC, again through the serial interface.

Parallel Interface

The parallel interface is controlled by 10 pins.

CS: Active low package select pin. This pin is shared with the **SYNC** function for the serial interface.

WR: Active low Write pin. The values on the address pins are latched on a rising edge of **WR**.

A5-A0: 6 Address pins (A5=MSB of address, A0=LSB). These are used to address the relevant channel (out of a possible 64).

Offset_Sel: Offset select pin. This has the same function as the **Offset_Sel** bit in the serial interface. When it is activated, the offset voltage control channel is addressed. The address on A5-A0 is ignored in this case.

Cal: Same functionality as the **Cal** bit in the serial interface (calibration instruction). When this pin is active, all 64 channels acquire V_{IN} simultaneously.

The **SER/PAR** bit must be tied low to enable the parallel interface and disable the serial interface.

AD5532/64 Prelim Technical Information

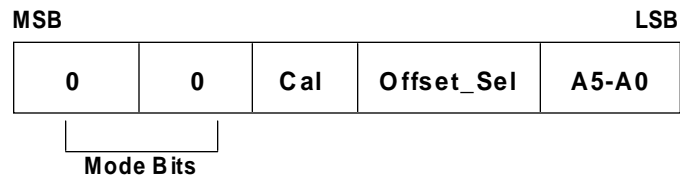

10-Bit Input Serial Write Word (SHA Mode)



24-Bit Input Serial Write Word (DAC Mode)

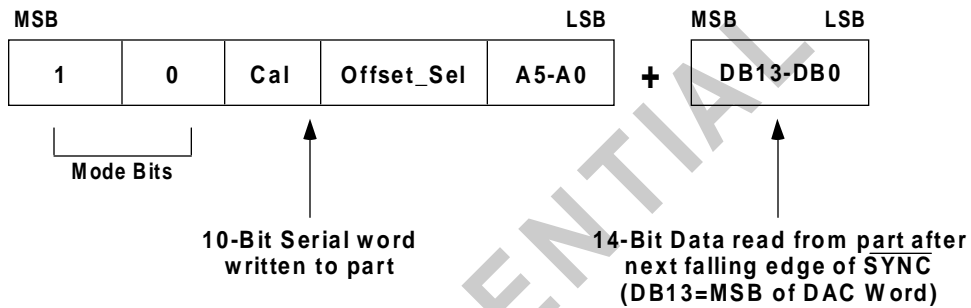

Input Serial Interface (Acquire and Readback Mode)

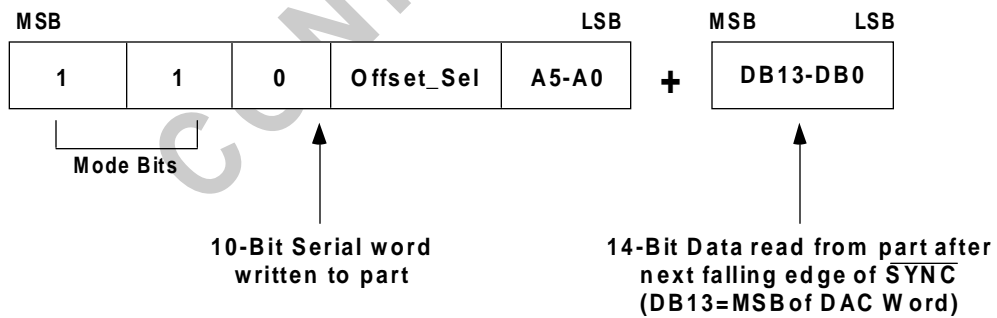

Input Serial Interface (Readback Mode)