

9311 93L11

1-OF-16 DECODER/DEMULTIPLEXER

DESCRIPTION — The '11 is a multipurpose decoder designed to accept four inputs and provide 16 mutually exclusive outputs. The 9311 is a faster replacement for the 74154.

- **MUTUALLY EXCLUSIVE OUTPUTS**
- **HIGH CAPACITIVE DRIVE CAPABILITY**
- **DEMULTIPLEXING CAPABILITY**
- **TYPICAL POWER DISSIPATION OF 175 mW FOR '11, 58 mW FOR 'L11**
- **2-INPUT ENABLE GATE**

ORDERING CODE: See Section 9

PKGS	PIN OUT	COMMERCIAL GRADE	MILITARY GRADE	PKG TYPE
		V _{CC} = +5.0 V ±5%, T _A = 0°C to +70°C	V _{CC} = +5.0 V ±10%, T _A = -55°C to +125°C	
Plastic DIP (P)	A	9311PC, 93L11PC		9N
Ceramic DIP (D)	A	9311DC, 93L11DC	9311DM, 93L11DM	6N
Flatpak (F)	A	9311FC, 93L11FC	9311FM, 93L11FM	4M

CONNECTION DIAGRAM PINOUT A

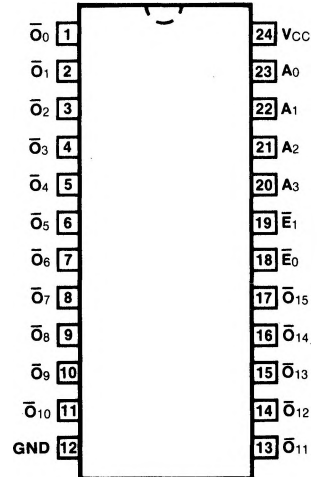

INPUT LOADING/FAN-OUT: See Section 3 for U.L. definitions

PIN NAMES	DESCRIPTION	93XX (U.L.) HIGH/LOW	93L (U.L.) HIGH/LOW
A ₀ — A ₃	Address Inputs	1.0/1.0	0.5/0.25
\bar{E}_0, \bar{E}_1	AND Enable Inputs (Active LOW)	1.0/1.0	0.5/0.25
\bar{O}_0 — \bar{O}_{15}	Decoder Outputs (Active LOW)	20/10	10/5.0 (3.0)

LOGIC SYMBOL

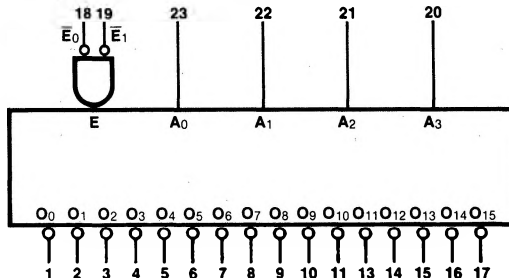

V_{CC} = Pin 24
GND = Pin 12

FUNCTIONAL DESCRIPTION — The '11 decoder accepts four inputs and provides 16 mutually exclusive active LOW outputs, as shown by the logic symbol. The active LOW outputs facilitate addressing other MSI units with active LOW enable. The '11 can demultiplex data by routing it from one input to one of 16 possible decoder outputs. The desired output is addressed and the data is applied to one of the enable inputs. Providing that the other enable is LOW, the addressed output will follow the state of the applied data.

TRUTH TABLE

INPUTS					OUTPUTS																	
\bar{E}_0	\bar{E}_1	A ₀	A ₁	A ₂	A ₃	\bar{O}_0	\bar{O}_1	\bar{O}_2	\bar{O}_3	\bar{O}_4	\bar{O}_5	\bar{O}_6	\bar{O}_7	\bar{O}_8	\bar{O}_9	\bar{O}_{10}	\bar{O}_{11}	\bar{O}_{12}	\bar{O}_{13}	\bar{O}_{14}	\bar{O}_{15}	
H	H	X	X	X	X	H	H	H	H	H	H	H	H	H	H	H	H	H	H	H	H	H
H	L	X	X	X	X	H	H	H	H	H	H	H	H	H	H	H	H	H	H	H	H	H
L	H	X	X	X	X	H	H	H	H	H	H	H	H	H	H	H	H	H	H	H	H	H
L	L	L	L	L	L	L	H	H	H	H	H	H	H	H	H	H	H	H	H	H	H	H
L	L	H	L	L	L	H	L	H	H	H	H	H	H	H	H	H	H	H	H	H	H	H
L	L	L	H	L	L	H	H	L	H	H	H	H	H	H	H	H	H	H	H	H	H	H
L	L	H	H	L	L	H	H	H	L	H	H	H	H	H	H	H	H	H	H	H	H	H
L	L	L	L	H	L	H	H	H	H	L	H	H	H	H	H	H	H	H	H	H	H	H
L	L	H	L	L	L	H	H	H	H	H	L	H	H	H	H	H	H	H	H	H	H	H
L	L	L	H	L	L	H	H	H	H	H	H	L	H	H	H	H	H	H	H	H	H	H
L	L	L	L	L	H	H	H	H	H	H	H	H	L	H	H	H	H	H	H	H	H	H
L	L	L	L	L	L	H	H	H	H	H	H	H	H	L	H	H	H	H	H	H	H	H
L	L	L	L	L	L	H	H	H	H	H	H	H	H	H	L	H	H	H	H	H	H	H
L	L	L	L	L	L	H	H	H	H	H	H	H	H	H	H	L	H	H	H	H	H	H
L	L	L	L	L	L	H	H	H	H	H	H	H	H	H	H	H	L	H	H	H	H	H
L	L	L	L	L	L	H	H	H	H	H	H	H	H	H	H	H	H	L	H	H	H	H
L	L	L	L	L	L	H	H	H	H	H	H	H	H	H	H	H	H	H	L	H	H	H
L	L	L	L	L	L	H	H	H	H	H	H	H	H	H	H	H	H	H	H	L	H	H
L	L	L	L	L	L	H	H	H	H	H	H	H	H	H	H	H	H	H	H	H	L	H
L	L	L	L	L	L	H	H	H	H	H	H	H	H	H	H	H	H	H	H	H	H	L
L	L	L	L	L	L	H	H	H	H	H	H	H	H	H	H	H	H	H	H	H	H	L

H = HIGH Voltage Level
 L = LOW Voltage Level
 X = Immaterial

LOGIC DIAGRAM

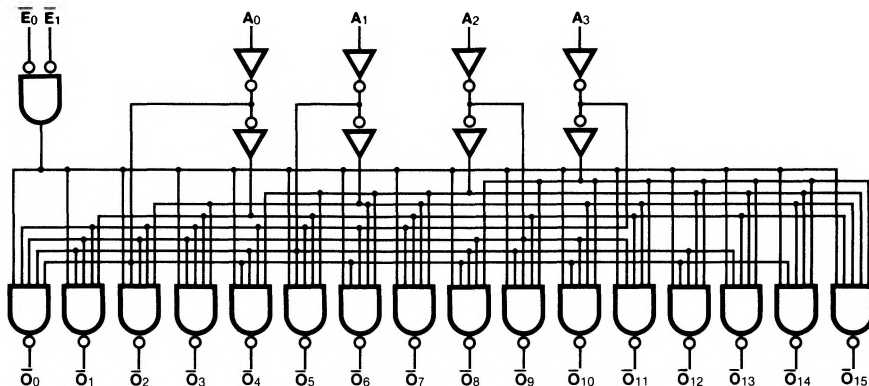

DC CHARACTERISTICS OVER OPERATING TEMPERATURE RANGE (unless otherwise specified)

SYMBOL	PARAMETER	93XX		93L		UNITS	CONDITIONS	
		Min	Max	Min	Max			
I _{OS}	Output Short Circuit Current	XM	-20	-55	-2.5	-25	mA	V _{CC} = Max, V _{OUT} = 0 V
		XC	-20	-57	-2.5	-25		
I _{CC}	Power Supply Current	XM	49		16.5		mA	V _{CC} = Max
		XC	56		16.5			

AC CHARACTERISTICS: V_{CC} = +5.0 V, T_A = +25°C (See Section 3 for waveforms and load configurations)

SYMBOL	PARAMETER	93XX		93L		UNITS	CONDITIONS
		C _L = 15 pF R _L = 400 Ω		C _L = 15 pF			
		Min	Max	Min	Max		
t _{PLH} t _{PHL}	Propagation Delay A _n to O _n	31 28		75 85		ns	Figs. 3-1, 3-20
t _{PLH} t _{PHL}	Propagation Delay E _n to O _n	23 24		60 65			