

# The White POWRTRON Amplifier

STANLEY WHITE\*

A discussion of one possible cause of power distortion and a description of a circuit developed to eliminate it. The author also describes his method of dividing the frequency spectrum ahead of the power amplifier. This unit has been popular with listeners at recent demonstrations.

**M**OST AMPLIFIERS are developed and tested using pure resistive load impedances across the secondary of the output transformer. Determination of intermodulation distortion, harmonic distortion, and power performance are based upon results obtained using these resistive loads although it is well recognized that speakers do not present a constant load impedance over the entire frequency spectrum. However, for want of a better method, resistive loads have been retained as a standard procedure in determining the performance and operating characteristics of amplifiers.

This paper proposes a basic change in amplifier circuitry that is inevitable if

amplifiers are to perform their basic function—that of presenting an electrical power waveform to a speaker in such a manner that the acoustical wave radiated from the surface of the speaker is a transformed replica of the voltage waveform at the input to the audio amplifier. It will be shown that present audio amplifiers create a power distortion of a magnitude of 6 to 8 db, and this type of distortion is not discernible by present day testing procedures.

*Definition 1.* Power distortion: A power waveform generated by an audio amplifier that deviates in any manner whatsoever from the form of the input voltage waveform is distorted with re-

spect to power to the extent of the deviation.

From this definition, it can be seen that any distortion measurement of an audio power amplifier is, in fact, a measurement of power distortion. That is, power distortion is a generalized form covering intermodulation distortion, harmonic distortion, and so on. Any amplifier that changes its power output with changing load impedance suffers from power distortion to the extent that the power output is altered. It is recognized that the relationship

\*Stan White Inc., 727 S. La Salle St., Chicago 5, Ill.

between power, voltage, and impedance can be expressed by the formula

$$P = \frac{E^2}{Z} \quad (1)$$

where  $P$  = power output,  
 $E$  = voltage, and  
 $Z$  = load impedance.

In test procedures using resistive loads, it can be seen that if  $E$  remains constant, the power output will remain constant. However, with variable load impedances the power output will bear an inverse relationship to the impedance.

From transducer theory, there are certain relationships between the electrical and acoustical characteristics of

any speaker, and such factors as the resistance of the suspension system, the resistance of the air load, the reactance of the voice coil and cone, the reactance of the air load, and the reactance of the suspension system must be considered as affecting the total impedance of the speaker, in addition to the pure electrical impedance of the voice coil itself.

#### Effect of Feedback

The majority of hi-fi amplifiers employ some form of voltage feedback, but a study of equation (1) will show that if voltage remains constant there will be considerable power distortion, and it is

agreed that voltage feedback tends to hold the voltage constant regardless of the load across the amplifier terminals. Thus any change in load impedance results simultaneously in an inverse power change. If electrical impedance characteristics and acoustical output characteristics of a given speaker were related in such a manner that electrical impedance peaks occurred simultaneously with acoustical peaks, the decrease in power response at the point of maximum acoustical output would be beneficial. However, in real speakers this condition seldom occurs.

The Powrtron circuit, Fig. 3, differs from conventional amplifiers in that it adds a small amount of negative current feedback to a usual amount of negative voltage feedback, with the result that over a reasonable range of load variations the power distortion is held to 1 db, whereas without the Powrtron feature the same amplifier shows a distortion of as much as 8 db.

Careful consideration of this will show that it is useless to attempt to control the behavior of a loudspeaker by means of a device that will sense impedance changes in the speaker, and this is exactly what is done with voltage feedback. Many other effects of voltage feedback are definitely beneficial, as is well known, but the effect on power distortion is to increase instead of decrease it.

Negative power feedback results in much less power change over a range of output loads than the other methods of operation. Positive current feedback reduces the internal impedance of power amplifiers to zero, but by so doing it increases power distortion.

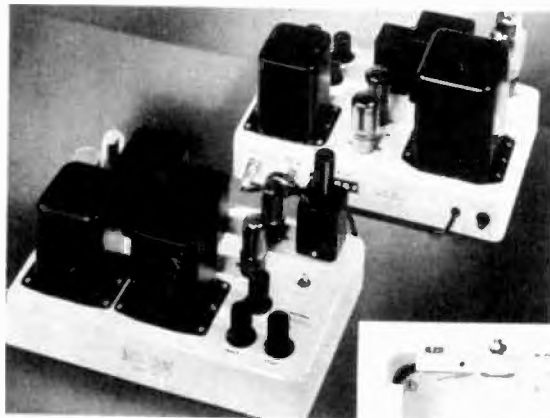

Fig. 1 (left). Top view of 10- and 20-watt White amplifiers with filter network plugged into the 10-watt unit. Fig. 3 provides for network to be plugged into the 20-watt low-frequency amplifier.

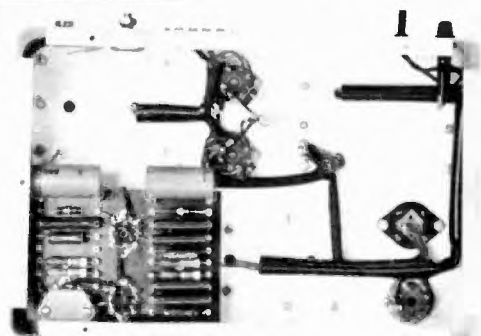

Fig. 2 (right). Underside view of the 20-watt amplifier. Large mica capacitor at lower left is  $C_6$ .

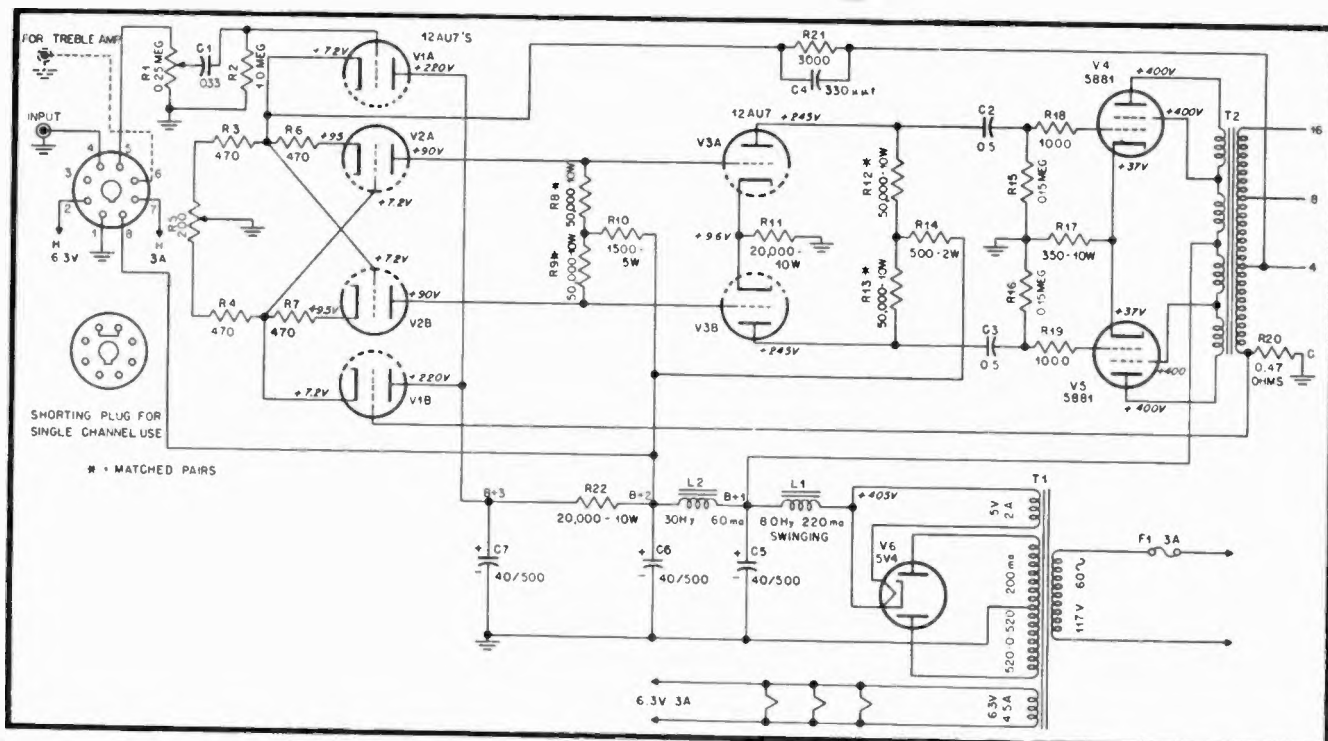

Fig. 3. Complete schematic of the 20-watt White amplifier arranged for plugging in the electronic filter network. 10-watt model is identical except for output tubes, which are 6V6's, and the output transformer.

### The Complete Circuit

While the Powrtron circuit refers only to the addition of a single resistor in the output circuit and the connection back to a suitable point for the introduction of feedback, there are some advantages to the complete White amplifier and the method of introducing two separate kinds of feedback is simplified greatly. In Fig. 3 it will be noted that  $R_{21}$  and  $C_4$  constitute a usual form of negative voltage feedback. The negative current feedback is obtained from  $R_{20}$  in the return leg of the secondary of the output transformer. The cross-coupled phase inverter, together with the direct-coupled driver stage make it possible to introduce the two different types of feedback with considerable ease. Furthermore, if a direct A-B test is desired, it is only necessary to short out  $R_{20}$ .

Since the circuit is somewhat unique, it may bear explanation. The input is fed into a level-adjusting potentiometer and thence to the grid of  $V_{1a}$  through  $C_1$  and the grid resistor  $R_2$ . (The use of the octal socket will be described later.)  $C_1$  and  $R_2$  may appear unnecessary, but the slightest amount of d.c. on the grid of  $V_{1a}$  is sufficient to unbalance the operation of the entire system so  $C_1$  is a mica capacitor—0.33  $\mu$ f or larger—which has been found to be completely free from leakage. The cathode of  $V_{1a}$  is directly coupled to the grid of  $V_{2b}$  and a tap on the cathode resistor string of  $V_{2a}$ ,  $R_3$ , provides for a balance of d.c. voltages throughout the first three tubes—the method of adjustment being to set  $R_3$  at a point where the voltage between the plates of  $V_{2a}$  and  $V_{2b}$  is zero. The negative current feedback is connected to the grid of  $V_{1b}$ —directly out of phase with the input section—and the output of  $V_{1b}$  is fed into the phase splitter in a manner similar to that from  $V_{1a}$ . The direct coupling between the phase splitter section and the driver is made possible by the use of a very large cathode resistor for  $V_3$ . It will be noted that these cathodes are about 96 volts above ground, resulting in a potential of approximately 90 volts on the plates of  $V_2$ —this same voltage being applied to the grids of  $V_3$  which results in a bias of around 6 volts.

The output stage is the Ultra-Linear, which has been described heretofore.<sup>1</sup> In the 20-watt White amplifier, 5881's are used; in a very similar design for 10 watts output, 6V6's are used—this latter amplifier being used with the 20-watt model to make the two-way amplifier system to be described.

The current feedback is developed across  $R_{20}$ , shown as 0.47 ohms. In construction, it is suggested that this value be obtained by the use of a 1-ohm 10-watt adjustable resistor. Slight variations in the power response characteristics may be had by changing the value of this resistor, with corresponding

changes in the tonal quality of the output.

Figure 2 shows the underside of the White amplifier. Note that most of the components ahead of the output stage are located on the terminal board, which is laid out as in Fig. 4. The parts list indicates the wattages of the various resistors, as well as the types recommended.

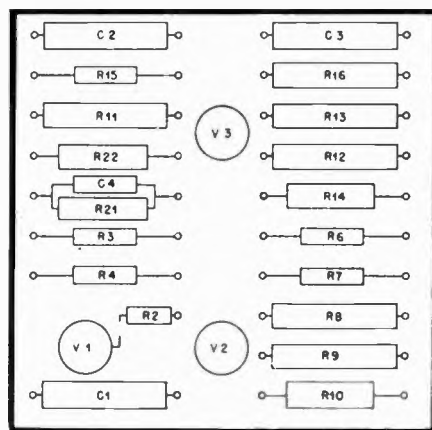

Fig. 4. Arrangement of parts on terminal board shown in Fig. 2.

In construction, it is suggested that the amplifier be assembled with semi-permanent connections between the driver stage and the output-tube grids, and with the negative-voltage feedback circuit— $R_{21}$ - $C_4$ —disconnected. Then pass a signal through the amplifier and note whether the signal increases or decreases when  $R_{20}$  is shorted. If the signal decreases, the leads to the two output grids should be reversed, since the feedback voltage developed across  $R_{20}$  should reduce the gain, and shorting the resistor eliminates the feedback. After the correct polarity is determined, the voltage-feedback circuit  $R_{21}$ - $C_4$  may be connected.

### The Octal Socket

The octal socket previously mentioned provides for the insertion of an electronic dividing network ahead of the power amplifiers. With the shorting plug in place, the amplifier functions normally, and may be used to feed a single speaker, or to feed a two- or three-way system with a conventional dividing network. However, one of the

advantages of the White system is that the dividing network is used ahead of the amplifiers, providing the advantage of low source impedance for the speakers. The principal disadvantage is the need for two power amplifiers, it being quite usual to use the 20-watt model for low frequencies and the 10-watt model for high frequencies.

The shorting plug simply connects the incoming signal to the input of the amplifier. However, when it is desired to use two amplifiers, the shorting plug is removed and an electronic filter unit is inserted in the socket. Figure 5 is the schematic of the filter network, which consists of a dual triode connected as two cathode followers. Each follower feeds a filter circuit—one of low-pass configuration, and one of high-pass configuration. The low-pass output is fed to the associated amplifier, and the other output is fed to the treble amplifier. In the commercially available model, the treble output is fed through a pigtail cable, which is plugged into the second amplifier. As shown in Fig. 3 the treble output is channeled to another phono jack, which is connected by a jumper to the second amplifier. The terminals shown are not those used in the commercial version, but are indicated for study of the circuit.

### Filter-Network Advantages

The most recent trend in amplifier design has been toward increased negative feedback, using output transformers of wider and wider range and placing more and more stages inside the feedback loop. For optimum operation, all of the push-pull stages should be balanced, and maximum phase shift must be kept to less than 180 deg. inside the feedback loop if oscillation is to be avoided.

The two regions in which phase shift will occur and oscillation becomes a problem are at the extreme ends of the audio spectrum. The ideal way to design an amplifier is to keep the phase shift through the electronic section of the amplifier limited to less than 5 deg. and allow the electrical characteristics of the output transformer determine the operating frequency of the amplifier. Unfortunately this ideal is seldom achieved.

It is well known that the reactive

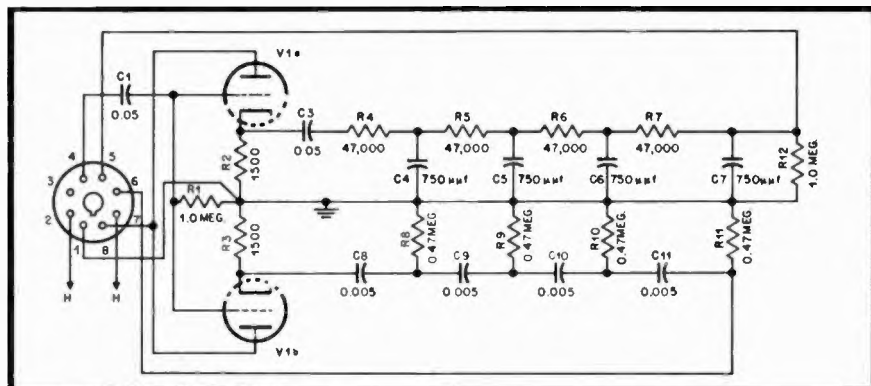

Fig. 5. Electronic filter network using a single 12AU7 as two cathode-follower sections to drive the R-C filters which comprise the dividing network ahead of the power amplifiers.

<sup>1</sup>David Hasler and Herbert I. Keroes, "The Ultra-Linear amplifier." *AUDIO ENGINEERING*, Nov. 1951.

filter networks cause substantial distortion in the process of sound reproduction. However, the manner in which it is caused is not nearly as well known. The design of filter sections of constant-valued elements of resistance, capacitance, and inductance is standard engineering practice. However, the design of filter sections capable of dealing with the variable impedance presented by a speaker is a problem of serious magnitude. The use of a dual-channel amplifier using electronic filter sections at the input of the system is deemed the best solution.

The crossover filter is constructed in a standard Vector CO-10-N turret can, making it readily interchangeable. Thus the experimenter can construct several different filter networks to determine the best operating crossover frequency for the speakers used, or by removing the network can restore the amplifier to normal operation with a minimum of effort. For the constants shown, the crossover frequency is approximately 560 cps.

In the hi-fi field the final judgement is always that of the listening test. In the case of amplifiers it is difficult to achieve a distinct improvement, but it is felt that a listening test with the crossover amplifier will give the listener just such a distinct improvement.

#### PARTS LIST (Fig. 3)

$C_1$	.033 $\mu$ f, 1200 v. mica
$C_2, C_3$	0.5 $\mu$ f, 600 v. paper
$C_4$	330 $\mu$ f, 500 v. mica
$C_5, C_6, C_7$	40 $\mu$ f, 500 v. elect.
$L_1$	8 H, 220 ma, swinging choke
$L_2$	30 H, 60 ma, smoothing choke
$R_1$	0.25 meg potentiometer, audio taper
$R_2$	1.0 meg, $\frac{1}{2}$ -watt, deposited carbon
$R_3, R_4, R_5$	470 ohms, 1-watt, wirewound
$R_6$	200 ohms, 4-watt potentiometer, linear
$R_7, R_8$	50,000 ohms, 10-watt, wirewound, matched pair
$R_9$	1500 ohms, 5-watt, wirewound
$R_{10}$	20,000 ohms, 10-watt, wirewound
$R_{11}, R_{12}$	50,000 ohms, 10-watt, wirewound, matched pair
$R_{13}$	500 ohms, 2-watt, wirewound
$R_{14}, R_{15}$	0.15 meg, 1-watt, deposited carbon
$R_{16}$	350 ohms, 10-watt, wirewound
$R_{17}, R_{18}$	1000 ohms, $\frac{1}{2}$ -watt, deposited

	carbon
$R_{19}$	1.0 ohms, 10-watt, adjustable, wirewound
$R_{20}$	3000 ohms, 1-watt, wirewound
$R_{21}$	20,000 ohms, 10-watt, wirewound
$T_1$	Power transformer, White Sound or Chicago PCR-200. 520-0-520 v at 200 ma; 5.0 v at 2.0 a; 6.3 v at 1.5 a; potted.
$T_2$	Ultra-Linear output transformer, Acro TO-300, or White Sound
$V_1, V_2, V_3$	12AU7
$V_4, V_5$	5881 or KT66
$V_6$	5V4

#### PARTS LIST (Fig. 5)

$C_1, C_2$	.05 $\mu$ f, 600 v. paper
$C_3, C_4, C_5$	
$C_7$	750 $\mu$ f, 500 v. mica
$C_8, C_9, C_{10}$	.005 $\mu$ f, 500 v. mica
$C_{11}$	
$R_1, R_{11}$	1.0 meg, $\frac{1}{2}$ -watt, deposited carbon
$R_2, R_3$	1500 ohms, 10-watt, wirewound
$R_4, R_5, R_6$	47,000 ohms, $\frac{1}{2}$ -watt, deposited carbon
$R_7$	
$R_8, R_9, R_{10}$	0.47 meg, $\frac{1}{2}$ -watt, deposited carbon
$R_{12}$	
$V_1$	12AU7