

# The Maestro—a POWER Amplifier

DAVID SARSER\* and MELVIN C. SPRINKLE\*\*

A new version of the now famous Musician's Amplifier which should satisfy anyone's desires for more power—and which uses a newly developed tube type with modest plate supply requirements.

**N**OAH WEBSTER, in his book of words, defines maestro as "a master in any art, especially music." This name is particularly appropriate to this amplifier, shown in Fig. 1, for it combines the best properties of the now famous Musician's Amplifier with a prodigious increase in power output. It is truly the master of the art of recreating music by electronic means.

The success of the Musician's Amplifier<sup>1</sup> is too well known to require repeating, but certain specialized applications have been encountered in which it did not fill the bill. We have in mind its power output, for its response, low distortion, and low noise level leave little to be desired for home music listening.

One application for which it is not entirely adequate is as a driver for a disc recording head. The low distortion makes the Musician's Amplifier attractive, but it falls short on power, especially when making LP discs where pre-emphasis is required. The considerations on power for disc recording are well known and have been mentioned by these writers previously.<sup>2</sup>

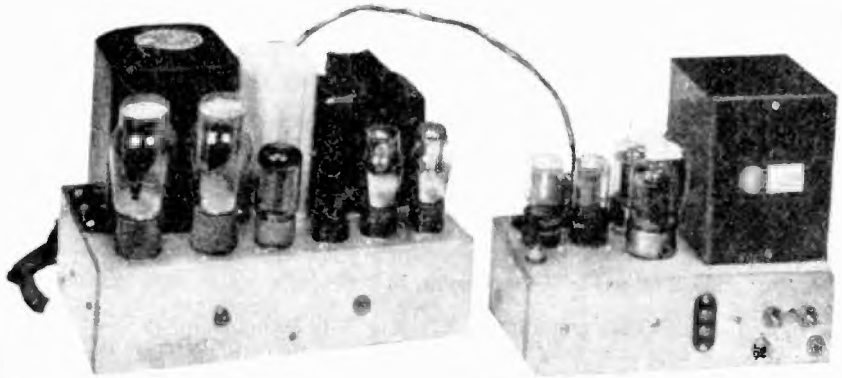

Fig. 1. The Maestro amplifier—a new contender for high-quality sound reproduction in the home, or for disc-recording cutter driving, or for any application where up to 90 watts is required.

The development of FM broadcasting, modern LP records, and tape equipment has set new standards for dynamic range in reproduced music. It is now necessary to re-appraise the power required for critical listening. In the past, the program material was compressed to a 35- or 40-db range and maximum power could be handled easily by the conventional "15-watt" amplifier. Today's trend is toward elimination of compression.

Therefore it is necessary to increase the power delivery of the amplifying system.

\* 548 Riverside Drive, New York 27, N. Y.

\*\* Sales Engineer, Ampex Corporation, Silver Spring, Md.

<sup>1</sup> Sarser and Sprinkle, "Musician's amplifier," *AUDIO ENGINEERING*, Nov. 1949.

<sup>2</sup> Sarser and Sprinkle, "Musician's amplifier senior," *AUDIO ENGINEERING*, Jan. 1951.

A typical example is in a recent recording of Ponchielli's "Dance of the Hours." In this selection, the pianissimo 'cello solo passage is repeatedly interrupted by a crashing chord played by the entire orchestra. With the usual 10- to 15-watt amplifier, the chord is heard, but without sufficient definition to suit the fastidious listener. In order to distinguish between the various choirs of the orchestra playing this chord, which the trained ear can do in a concert hall, it is necessary that considerable power be available. A measurement of the peak produced by the chord shows around 22 db of change in instantaneous power. This is not, however, a true measure of the peak but is an integrated reading. This means that an amplifier of around 100 watts is required. Since this chord contains fundamental frequencies between 30 and 4000 cps, it may be seen that full power is required at these frequencies. In addition to power over this range, "clean" power is required up to at least 15,000 cps for disc recording as considered previously. Hence, we have looked toward the development of an amplifier which would combine the low distortion, low noise, and wide range of the Musician's Amplifier, with substantially increased power output.

While the Musician's Amplifier Senior<sup>2</sup> was a step in the right direction, it had several shortcomings: it is large in size; it requires a power supply much like a transmitter, and which can be lethal; it requires a power amplifier as a driver; and it is like all Class A amplifiers—inefficient. And in high-power amplifiers, efficiency becomes important.

#### New Tube Gives Clue

The recent announcement of the type 6146 by RCA pointed toward a solution of the need for more power with comparatively simple circuit design. This tube is a beam-power amplifier tube primarily intended for transmitter use. As shown in Fig. 2 in comparison with the 5881 and the KT-66, it is small in size, sturdily constructed; and it has a high power sensitivity. It can be used in a number of transmitter applications, but RCA's data sheet indicates that it will also serve as an audio power amplifier or modulator, Class AB. This data sheet recommends—under ideal conditions such as perfectly regulated power supplies—that a pair of 6146's be operated with a plate voltage of 750 and a screen voltage of 200. This requires a fixed bias of 50 volts and a plate-to-plate load of 8000 ohms. Under these conditions, the power output is approximately 120 watts into a plate-to-plate resistor. As a practical matter, we have departed slightly from these conditions and obtained a sine-wave power output of 90 watts from 25 to 30,000 cps. All this and Class AB, too, with no driver and no grid-current problems. The 6146 can be operated readily with resistance coupling from a voltage amplifier—and thus may be said

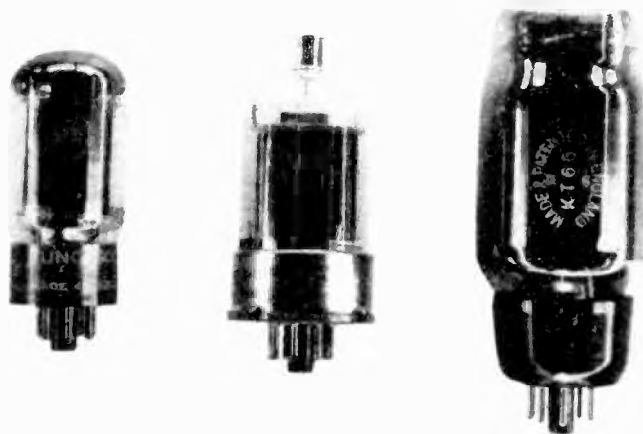

Fig. 2. Comparative size of the new RCA 6146 alongside the 5881 and the KT-66.

to be a "jolly good bottle."

Having found a satisfactory tube type, the next problem was to find a suitable output transformer. Search of transformer catalogs failed to reveal one which would meet all requirements, so a conference was held with E. B. Harrison, of Peerless. On hearing the problem he said, "I think I can do it." Subsequently he has admitted it was a tough one. However, Harrison designed and built an output transformer for the 6146, and although originally built especially for this first amplifier, it is now in the Peerless line as type S-268-Q. When tested in a matched network, the response is within 1 db from 10 cps to 100,000 cps. Primary impedance is 8000 ohms, and it will handle 50 watts at 20 cps, and at least 80 watts mid-range. When used in a feedback amplifier where the source impedance is 10 per cent or less of the reflected primary impedance, the transformer will deliver close to 80 watts with no visible distortion at 20 cps. Primary inductance at 5 volts, 60 cps, is greater than 200 henries, while at 80 watts the inductance is approximately 800 henries, yet the leakage inductance referred to the primary is around 7 mh. The d.c. resistance of the primary is 115 ohms, and the insertion loss around 7 per cent. Small in size for its power rating this transformer has proved to be excellent in perform-

ance, and will pass a 30,000 cps square wave with a vertical rise and a flat top.

#### The Voltage Amplifier

Large triodes like the 845 have a high bias, and transformer coupling is almost a necessity. A power amplifier of some size is also required to produce the necessary voltage. The 6146, in common with other beam tubes, operates at a reasonable bias of 50 volts. It requires around 35 volts r.m.s. per tube, or 70 volts for a push-pull pair for grid excitation, and this is quite in line with the 807 or 5881 drive requirements in the Musician's Amplifier. Thus, the voltage amplifier of the earlier amplifier was adopted without change, as is observed from the schematic, Fig. 3.

Design of the power supply proved to be a bigger job. In the Musician's Amplifier Senior, the power supply resembled that of a small transmitter, and the problem was current capacity and high voltage. In the Maestro amplifier, the problem is regulation, since operation is Class AB. According to the data sheet, the plate current for a pair of tubes goes from a quiescent 57 ma to a peak of 227 ma, while the screen current changes from 1 ma quiescent to 27 ma at 120 watts. Another problem was to obtain the 750 volts with the choke input that good regulation dictates. One

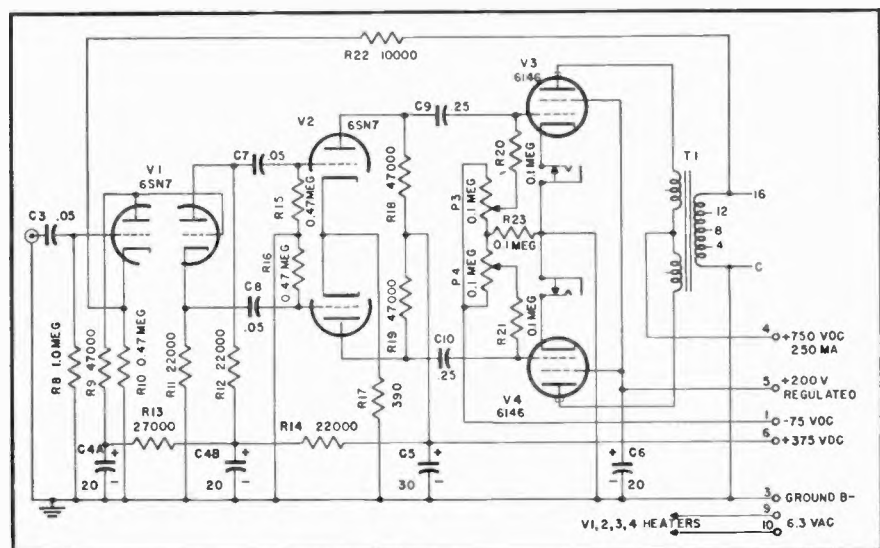

Fig. 3. Complete schematic of the Maestro. Note similarity to the Musician's amplifier.

solution was found by using two receiver-type transformers with the high-voltage windings in series. The primaries are paralleled across 117 volts a.c. and the secondaries are phased so as to obtain 1600 volts r.m.s. from rectifier plate to plate. The two-transformer scheme also provides the several 6.3-volt heater windings which are required.

The rectifiers employed are the high-vacuum, high-voltage 5R4GY, ideal for heavy-duty use. Two are used in parallel. In preliminary work, a swinging choke was used as input to the filter but it was found that a conventional smoothing choke works just as well. The requirements of sufficient minimum inductance and low d.c. resistance are met by the unit selected. The single high-voltage filter capacitor is oil filled.

One of the important requirements in obtaining high quality from beam tubes is regulation of screen voltage. This is not always mentioned in connection with amplifier construction articles and so does not receive the recognition it deserves. In our preliminary work we used VR tubes to regulate the screen voltage but had poor luck. By the time the screen voltage was stable, the VR tubes were well past their rated currents. Therefore the VR tubes were abandoned and an electronically regulated supply installed. A triode-connected 5881 is used as a pass tube, and a 6SJ7 is used as the control tube, with a VR-75 supplying the reference voltage. Bleeder current is passed through the VR-75 so that changes in 6SJ7 current have no effect.

#### Power Supply Circuits

Referring to the schematics for the power supplies—Figs. 4 and 5—it will be noted that the screen supply circuits are similar. During the development program, two types of power supplies were constructed. The first type used two receiver-type power transformers, with the high-voltage windings series-connected. The second employed a standard type of plate transformer which delivers 900 volts each side of center tap. This latter unit has a streamlined appearance, and results in an attractive power supply, but a number of extra filament transformers must be employed. Figure 4 shows the schematic of the two-transformer supply, with a number of filament windings being available on the existing transformers. Figure 5 shows the unit employing the single plate transformer with a multiplicity of filament transformers. There are advantages to both arrangements, but aside from the differences in transformer connections, the remainder of the power-supply circuit is essentially identical in both types of construction.

Referring to the regulator circuit, it is seen that the potentiometer  $P_1$  is used to set the output voltage to exactly 200 volts—although it may be set anywhere in the range from 150 to 250 volts. Changes in input voltage have no effect. It will also be noted that the 6146's are operated with fixed bias. To provide this, a separate circuit is employed, using the 1-to-1 isolation trans-

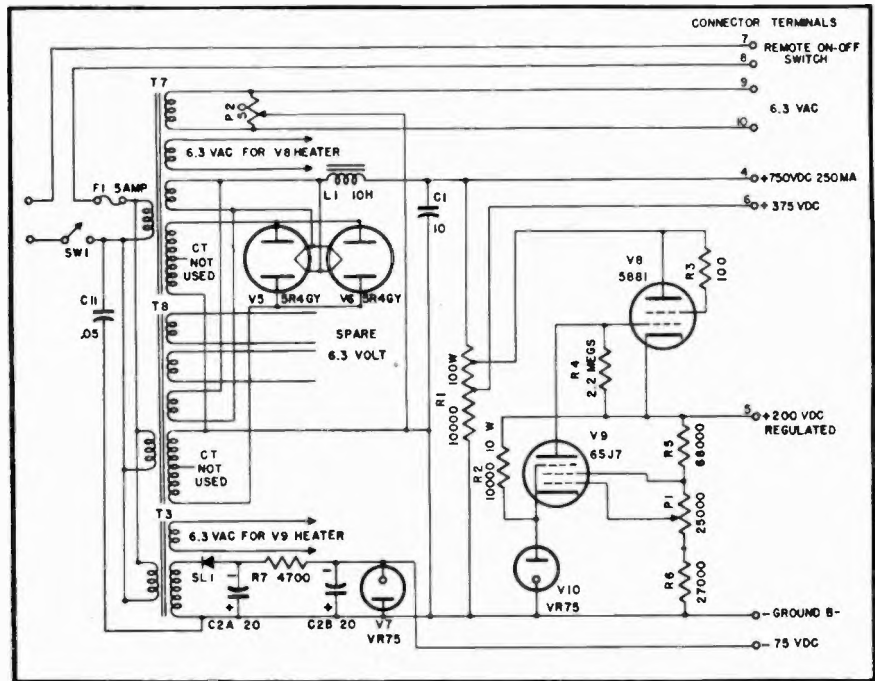

Fig. 4. Schematic of the No. 1 power supply, which employs two conventional receiver power transformers and the bias-supply transformer.

former and a 75-ma selenium rectifier. Another VR-75 tube is used to stabilize this voltage, and enough current is drawn to make it steady. Two potentiometers,  $P_1$  and  $P_2$ , are used in the amplifier to balance plate currents as well as to set the bias. Note that the positive side of the bias supply is grounded; therefore, the anode of the VR-75 should be grounded, and the cathode connected to the negative side of the bias supply.

A 100-watt, 10,000-ohm bleeder resistor is used to supply the 400-volt requirements of the regulated screen supply and the 375-volt requirements for the voltage amplifier. Details of the circuit are seen in the schematic, with the parts listed at the end of the article. 10-contact Jones plugs are used to interconnect the amplifier and the power supply. No

trouble has been encountered in cabling the 750-volt plate supply with the other wiring, but care should be taken to place all live connections on female connectors.

#### Performance

The performance of the Maestro amplifier fully justifies the name. The general requirements for frequency response, power output, distortion, and noise have been stated, and the results will be considered in that order.

The frequency response was measured with a 1000-ohm source resistance as this is typical of the source impedance of cathode followers used in the better "front ends." Under these conditions, the response is flat with no perceptible variation from 10 to 70,000 cps. There

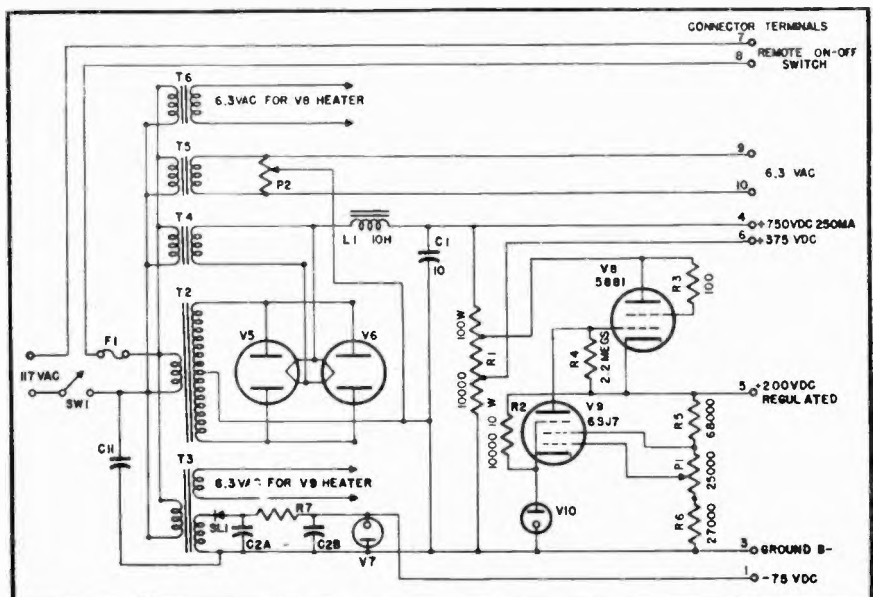

Fig. 5. Schematic of the No. 2 power supply, using a plate transformer and several filament transformers, in addition to the bias-supply unit.

is a 1.5-db rise at 5 cps, and there is a droop of 0.6 db at 100,000 cps. These frequencies represent the limits of our present measuring equipment. From the smoothness and steepness of the square-wave transmission, it appears that the response is better than the measured value. The completed amplifier passes square waves even better than the Musician's Amplifier, up to a 10,000-cps fundamental. At 30,000 cps the rise time is still vertical while preserving a flat top.

The single-frequency power output at 1000 cps is 90.2 watts, as shown in Fig. 6. This is just before the sine wave begins to be clipped, and when clipping does occur the clip is clean and symmetrical. There is no "fuzz" when the amplifier overloads. Full 90 watts is obtained at all frequencies from 25 to 20,000 cps with a smooth decline beginning at 30,000 cps, the 3-db-down point being at 40,000 cps. At low frequencies, the 3-db-down point is at 10 cps. The low-frequency performance of the amplifier when feeding a speaker load is superb.

The low distortion of the Maestro makes it a worthy part of a high-quality music installation. Using the power output as read on the IM set meter shows an IM distortion of 4 per cent only 1 db below 90 watts; at 2 db below 90 watts, the IM distortion is only 2 per cent, as shown graphically by the solid curve of Fig. 7. An important consideration in analyzing IM curves is the location of the "break" from a low-distortion flat portion of the curve to the upward bend. The ideal curve as a function of power would be horizontal up to the break point, then would rise sharply upward. This is the type of curve obtained from the Maestro. The break occurs at around 60 watts as read on the IM meter. From examination of the composite IM signal as viewed on an oscilloscope, it is evident that it is a complex wave and that meters calibrated on sine waves will not give a true measure of the IM signal output and hence the actual power output of the amplifier.

Thus it is desirable to find an equivalent sine wave which has the same peak value as the sum of the peak values of the low- and high-frequency components in the IM signal. Aston<sup>3</sup> points out that adding a second tone to another tone causes less than 0.5 db increase in a VU meter indication, but actually the peak amplitude of the combined signal is 1.25 times that of the low frequency. Aston also points out that IM meter measurements can be converted to equivalent sine-wave power by multiplying the IM meter power by 1.47. Strictly speaking, the term "equivalent sine wave" has no point in IM measurements since the term IM presupposes two frequencies. However, the concept is useful and does check with practice. Examination of the IM curve shows the break at around 60 watts. On equivalent sine wave, this is 88.3 watts, as

<sup>3</sup> R. H. Aston, *Technica*, AUDIO ENGINEERING, Sept. 1948.

Fig. 6. Power output vs. frequency curve for the Maestro amplifier.

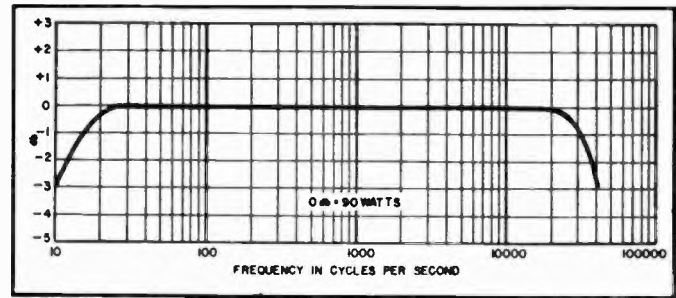

shown by the dotted curve in Fig. 7. This is close to the 90 watts—the power output at which a sine wave begins to be distorted. The amplifier can be considered to be almost distortionless below 75 watts on a sine-wave basis, since this corresponds to around 50 watts on the IM curve which is well below the knee or break-point.

The gain of the Maestro amplifier from a 1000-ohm source impedance—which is representative of cathode followers—is 50 db. This is measured in accordance with methods described by Haefner<sup>4</sup> and represents the power increase that is obtained from a 1000-ohm source whose open-circuit voltage is 1.9 volts. If this generator is terminated in a 1000-ohm load, the power in this load is .00091 watts. If the load be removed

damping factor of 10.6, which is entirely satisfactory on any speaker. No traces of hangover have been detected on any of the speakers used.

#### Preliminary Output Transformer Tests

During early development and before the arrival of the output transformer designed for this amplifier, tests were made using various other output transformers. Table 1 shows the results obtained with three transformers which were available: (A) Peerless S-265-Q, with a primary impedance of 10,000 ohms, 40 watts; (B) Western Electric KS-9496 Beachmaster transformer, primary impedance 9000 ohms, 250 watts; and (C) Partridge deluxe type CFB, primary impedance of 10,000 ohms, 60 watts.

Fig. 7. Intermodulation distortion curves for the Maestro. The solid curve represents distortion for power output as read on the IM set meter. The dotted curve represents the same distortion plotted against equivalent sine-wave power.

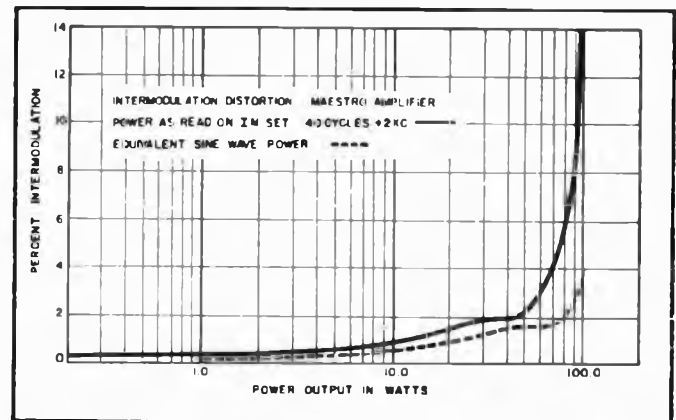

and the amplifier connected, the power output will be 90 watts, or a 50-db increase. For those not familiar with this gain concept, let us state that the Musician's amplifier has a gain of 44 db by this method. For those not familiar with the gain requirements of their preamplifiers, it may be said that if the preamplifier will deliver 1.9 volts into a 0.5-meg load, the Maestro will put out the full 90 watts.

The noise level with the input shorted is around 5 mv across 16 ohms, which comes out to -28 dbm. This is 77.5 db below 90 watts, which is reasonably good for an amplifier of this power. In practice, it has been found that the noise is inaudible at 1 foot from efficient modern speakers.

The internal output impedance, or the source impedance which feeds the speaker, is 1.5 ohms on a 16-ohm strapping of the secondary. This gives a

<sup>4</sup> Sylvester J. Haefner, "Amplifier gain measurement." *Proc. I. R. E.*, July 1946, p. 500.

Table 1  
POWER OUTPUT IN WATTS

Frequency cps	Transformer		
	(A)	(B)	(C)
20	50.7	11.0	42
30	64	23.8	56
40	64	36.0	56
100	64	75.0	56
1000	64	75.0	56
5000	60	75.0	56
10000	34.4	66.6	56
20000	30.2	58.9	39

In fairness to all concerned, it should be stated that only the Beachmaster was intended for service such as imposed by the 6146, but it had very poor low-frequency power delivery, being intended for voice only. However, the other transformers are well known and were on hand so they could be tried readily.

Intermodulation measurements, using 60 and 3000 cps mixed at a 4-to-1 ratio, produced the results shown in Table 2.

**Table 2**  
**INTERMODULATION DISTORTION**

Power Output on IM set Watts	Transformer		
	(A)	(B)	(C)
56.2	23	10	21
42	1.5	1.4	3.5
36	1.3	1.7	1.5
25	1.2	1.3	1.0
6.2	0.7	0.5	0.5

Note that in the power output data the greatest midrange power comes from the Beachmaster which has the lowest d.c. resistance, but power at low frequencies is poor. Note also that IM measurements made at 60 cps for the low frequency do not show up the Beachmaster. Had 40 cps been used, the difference would have been apparent.

All tests were made under identical conditions using the series-connected power supply and VR tubes for screen regulation. 20 db of feedback was used. Under the same conditions, the Peerless S-268-Q developed 80 watts from 25 to 30,000 cps instead of 75 watts for the Beachmaster.

#### Listening Quality

We have said many times that listening quality in music is everything. In building a new amplifier, we naturally try to get the widest range, least distortion, and most power, but if the finished product does not sound better, time is wasted. Through the courtesy of Walter Toscanini, we had at our disposal some really fine tapes and a wide variety of loudspeakers to check the listening quality of this new amplifier. It turned out to be truly the finest reproduced music that we have ever heard. It has been fed into large two-way speakers where the superiority is immediately evident, and it has even been

tried on speakers rated at 10 watts where it adds immeasurably to the performance. However, let us warn that this amplifier must be used with caution. In particular, great care must be taken to eliminate switching clicks in early stages as well as pops from phonograph motor switches. With the gain well advanced, any such click is almost certain to damage the loudspeaker—particularly the tweeter, if one is used—because of the high power capability of the amplifier. Remember that you can't crank up the gain on this amplifier without considering the program material any more than you can jam down the gas pedal on a super-powered car without considering the traffic conditions. A word to the wise is sufficient.

We have said that the Musician's amplifier is good, and that statement still stands for 99 44/100 per cent of music lovers, but for the 56/100 per cent who want the last word in realism as of the present state of the art, here is the amplifier. Just try it and see—but remember the precautions.

#### Parts List

##### Amplifier and Power Supplies

$C_1$	10 $\mu$ f, 1000 v, oil-filled
$C_2$	20-20 $\mu$ f, 150 v, electrolytic
$C_3$	.05 $\mu$ f, 400 v, paper
$C_4$	20-20 $\mu$ f, 450 v, electrolytic
$C_5$	30 $\mu$ f, 500 v, electrolytic
$C_6$	20 $\mu$ f, 450 v, electrolytic
$C_7, C_8$	.05 $\mu$ f, 600 v, paper
$C_9, C_{10}$	0.25 $\mu$ f, 600 v, paper
$C_{11}$	.05 $\mu$ f, 600 v, paper, metal-cased
$F_1$	5-amp 3AG Littelfuse
$L_1$	10 H, 250 ma, filter choke; Peerless C-455-A or equivalent
$P_1$	25,000-ohm potentiometer, linear
$P_2$	50-ohm potentiometer, wire-wound
$P_3, P_4$	0.1-meg potentiometers, linear

$R_1$	10,000 ohms, 100 watt, wire-wound, adjustable, with two sliders
$R_2$	10,000 ohms, 10 watt, wirewound
$R_3$	100 ohms, 1 watt
$R_4$	2.2 megs, 1 watt
$R_5$	68,000 ohms, 2 watts
$R_6$	27,000 ohms, 2 watts
$R_7$	4700 ohms, 1 watt
$R_8$	1.0 meg, $\frac{1}{2}$ watt
$R_9$	47,000 ohms, 1 watt
$R_{10}$	0.47 meg, 1 watt
$R_{11}, R_{12}$	22,000 ohms, 1 watt, matched
$R_{13}$	27,000 ohms, 1 watt
$R_{14}$	22,000 ohms, 1 watt
$R_{15}, R_{16}$	0.47 meg, $\frac{1}{2}$ watt
$R_{17}$	390 ohms, 1 watt
$R_{18}, R_{19}$	47,000 ohms, 2 watts, matched
$R_{20}, R_{21}$	0.1 meg, 1 watt
$R_{22}$	10,000 ohms, 1 watt for 20-db feedback
$R_{23}$	0.1 meg, 2 watts
$T_1$	Output transformer, Peerless S-268-Q; 8000-ohm primary to 16, 12, 8, and 4 ohm secondary, 90 watts power capacity
** $T_2$	900-0-900 v at 250 ma; Chicago P-67
$T_3$	125 v, 15 ma, half-wave; 6.3 v at 0.6 a; Stancor PS-8415
** $T_4$	Filament transformer, 5 v at 4 a; Chicago FO-56, Peerless F-138-E, or equivalent
** $T_5$	Filament transformer, 6.3 v at 3.0 a; Chicago FO-63, Peerless F-072-X, or equivalent
** $T_6$	Filament transformer, 6.3 v at 1.5 a; Chicago FO-615, Peerless F-036-X, or equivalent
* $T_7, T_8$	400-0-400 v at 300 ma; 6.3 v at 4.0 a; 6.3 v at 5.0 a; 5 v at 4.0 a; Peerless R-800-A or equivalent
$V_1, V_2$	6SN7
$V_3, V_4$	6146
$V_5, V_6$	5R4GY
$V_7, V_{10}$	VR 75
$V_8$	5881
$V_9$	6SJ7

\* Use only in power supply #1

\*\* Use only in power supply #2